

*Advancing the Science of Sealing™*

# Garlock Metallic Gasket Catalog



**Garlock**  
SEALING TECHNOLOGIES®

an EnPro Industries company

# Garlock Metallic Gaskets

Garlock Metallic Gaskets, a division of Garlock Sealing Technologies, manufactures spiral wound, metal clad, solid metal and metal core gaskets at its facility in Houston, Texas. This facility is registered to ISO-9001.

In recent years, Garlock Metallic Gaskets has introduced some of the industry's most innovative production methods and products. For example, the CONTROLLED DENSITY™ process for spiral wound gaskets ensures a high tightness level at a lower bolt stress. The TANDEM SEAL™ combines chemical resistance and fire safety in a single gasket. The Garlock EDGE® gasket seals at lower bolt stress while virtually eliminating the problem of inward buckling. Garlock Metallic Gaskets is also known for excellence in material and product quality as well as its outstanding customer service.

This catalog is provided for customer information and convenience. However, Garlock Metallic Gaskets applications engineers and customer service personnel are also on hand to assist you with your application requirements and technical questions. Please give us a call at 1-888-GARLOCK. We are here to serve you.



CONTROLLED DENSITY™, TANDEM SEAL™, STABL-LOCK™ and G.E.T.™ are trademarks of Garlock Inc.  
EDGE®, GRAPHONIC®, FLEXSEAL® and TEPHONIC® are registered trademarks of Garlock Inc.

## Contents

### Metallic Gasket Styles

|   |      |
|---|------|
| Gasket Selection .....                          | D-2  |
| Spiral Wound Gaskets .....                      | D-3  |
| Performance Metrics .....                       | D-4  |
| The Garlock EDGE® Gasket .....                  | D-5  |
| HEAT SHIELD™ Gasket .....                       | D-6  |
| TANDEM SEAL™ Gasket .....                       | D-7  |
| FLEXSEAL® Family .....                          | D-8  |
| RW, RWI, SW (For ASME flanges) .....            | D-8  |
| MC, MCR (For boiler manholes) .....             | D-9  |
| HH (For boiler handholes) .....                 | D-10 |
| RW-RJ, RWI-RJ (For ring joint flanges) .....    | D-11 |
| LMF (For large male/female flanges) .....       | D-12 |
| LTG (For large tongue and groove flanges) ..... | D-12 |
| STG (For small tongue and groove flanges) ..... | D-12 |
| Exchanger and Vessel Gaskets .....              | D-13 |
| Heat Exchanger Gasket Configurations .....      | D-13 |
| 600 Series Metal-Clad Gaskets .....             | D-14 |
| GRAPHONIC® Metallic Gasket .....                | D-16 |
| Garlock Kammprofile Gasket .....                | D-17 |

### Engineering Data

|  |      |
|--|------|
| Factors Affecting Gasket Performance ..... | D-18 |
| Material Temperature Limits .....          | D-19 |
| Thickness and Tolerances .....             | D-19 |
| Flange Types .....                         | D-20 |
| Recommended Flange Finish .....            | D-21 |
| Maximum Bore .....                         | D-22 |
| Gasket Dimensions .....                    | D-23 |
| Gasket Factors M and Y .....               | D-32 |
| Torque Tables .....                        | D-33 |
| Flange and Bolt Dimensions .....           | D-39 |
| Gasket Installation .....                  | D-40 |
| Troubleshooting Leaking Joints .....       | D-41 |
| Ordering Guide .....                       | D-42 |
| Application Data Form .....                | D-43 |

# Gasket Selection

## Spiral Wound Gaskets

One of the best all-around seals, the spiral wound gasket offers a low-cost solution that has the ability to handle temperature and pressure fluctuations. Multiple plies of metal and filler in the spiral create a barrier that reduces the possibility of leaks.

## Other Metal Gaskets

Garlock manufactures a wide variety of double-jacketed, spiral-wound, metal-clad and solid metal gaskets for heat exchanger and coker applications. GRAPHONIC® and Kammprofile gaskets are also available in heat exchanger configurations.

## Temperature and Chemical Considerations

Be certain that the gasket you order is as resistant as possible to the media and temperature involved. Check the chemical compatibility of the metal as well as the filler material for the media to be sealed. As a general rule, the metal used in either the spiral winding or double-jacketed gasket should be similar to the flange material.

The compressibility of flexible graphite makes it an excellent filler material for metallic gaskets. Flexible graphite may be used in services with temperatures up to 850°F (450°C), though it should not be used with strong

oxidizers such as nitric or sulfuric acid.

PTFE filler material provides excellent chemical resistance at temperatures below 500°F (260°C). In accordance with ASME B16.20, an inner ring is required when using conventional PTFE filler materials, in order to protect the winding from radial buckling.

See page D-19 for the temperature limits of common metals and filler materials.

## Operating Pressure

Operating pressures have a direct effect on the construction and selection of metallic gaskets. Higher pressures raise the potential for gasket blowout, while lower pressure applications require a gasket design that seals under lower bolt loads.

Garlock gaskets suitable for high pressure include:

- Kammprofile gaskets
- Spiral wound gaskets with inner ring
- Solid metal gaskets

Low pressure gaskets include:

- GRAPHONIC® gaskets
- Garlock Kammprofile gaskets
- The Garlock EDGE® gasket

### WARNING:

Properties/applications shown throughout this brochure are typical. Your specific application should not be undertaken without independent study and evaluation for suitability. For specific application recommendations consult Garlock. Failure to select the proper sealing products could result in property damage and/or serious personal injury.

Performance data published in this brochure has been developed from field testing, customer field reports and/or in-house testing.

While the utmost care has been used in compiling this brochure, we assume no responsibility for errors. Specifications subject to change without notice. This edition cancels all previous issues. Subject to change without notice.

# Spiral Wound Gaskets

## Manufactured in Accordance with ASME B16.20

Spiral wound gaskets—made with an alternating combination of formed metal wire and soft filler materials—form a very effective seal when compressed between two flanges. A v-shaped crown centered in the metal strip acts as a spring, giving gaskets greater resiliency under varying conditions. Filler and wire material can be changed to accommodate different chemical compatibility requirements. Fire safety can be assured by choosing flexible graphite as the filler material. If the load available to compress a gasket is limited, gasket construction and dimensions can be altered to provide an effective seal.

A spiral wound gasket may include a centering ring, an inner ring or both. The outer centering ring centers the gasket within the flange and acts as a compression limiter, while the inner ring provides additional radial strength. The inner ring also reduces flange erosion and protects the sealing element.

Resiliency and strength make spiral wound gaskets an ideal choice under a variety of conditions and applications. Widely used throughout refineries and chemical processing plants, spiral wound gaskets are also effective

for power generation, pulp and paper, aerospace, and a variety of valve and specialty applications.

As set forth in ASME B16.20, all PTFE filled spiral wound gaskets will be supplied with inner rings. In addition, the following higher pressure class spirals will be supplied with inner rings for all filler material:

- NPS 24 and larger 900#
- NPS 12 and larger 1500#
- NPS 4 and larger 2500#

Starting in May 2008, the metricated edition of this standard recommends the use of inner rings for all graphite filled spiral wound gaskets. However, these gaskets may be specified without inner rings by the purchaser. Both styles will still be stamped ASME B16.20 compliant on the outer guide ring.

## Gasket Identification Markings Required by ASME B16.20

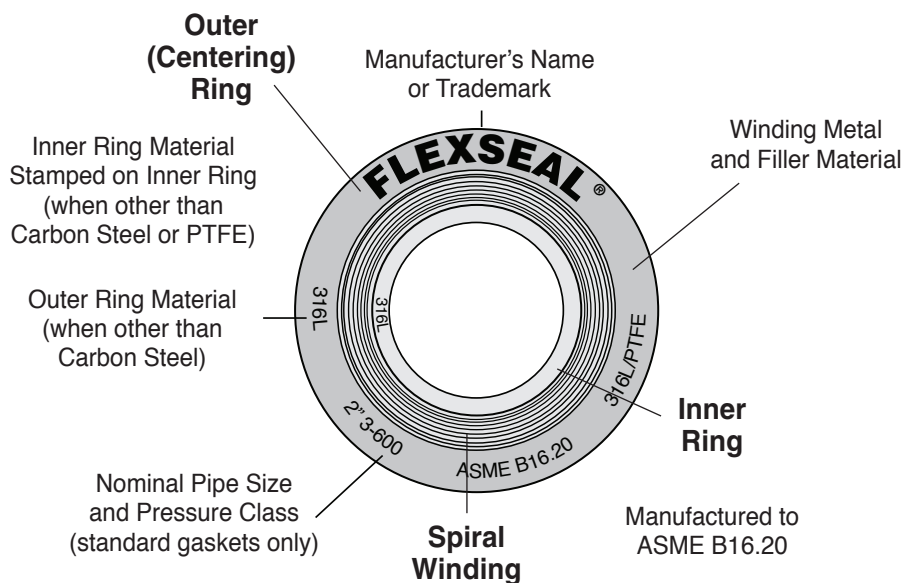

# Performance Metrics

## Controlled Density™ Process

- Garlock manufacturing process ensures optimum filler density across the gasket winding to achieve consistent compression and superior sealability
- High tightness level achieved with minimal compressive load, for longer-lasting seal
- All SW gaskets manufactured in accordance with the guidelines set forth in the ASME B16.20 specifications



## ROTT Test and Results

### ROTT Test

- **Purpose:** Determine room temperature sealing capabilities, by measuring the sealability of a gasket at incremental gasket stress values
- **Sample used:** Two 304 SS and flexible graphite-filled 4" Class 150 ASME B16.20 spiral wound gaskets
- **Procedure:** The leak rate is measured during the loading and unloading cycles, and a tightness curve is generated.\*

### Test Results

- When compared with other spiral wound gaskets, the Garlock metallic gasket was able to achieve equivalent tightness at a lower load in all tightness parameter values.
- During stress cycling, the performance of the Garlock metallic gasket gaskets was excellent, compared with other spiral wound gaskets.

| Gasket Style and Material                                      | Gasket Factor "M" | Gasket Factor "Y" (psi) |
|--|-------------------|-------------------------|
| Traditional spiral wound gasket – 304 SS and flexible graphite | 3.00              | 10,000                  |
| Garlock spiral wound gasket                                    | 3.00              | 7,500                   |

| Gasket Material  | Gasket Constant Gb (psi) | Gasket Constant 'a' | Gasket Constant Gs (psi) | Stress Req'd for Tightness of 100 (psi) | Stress Req'd for Tightness of 1000 (psi) | Stress Req'd for Tightness of 10,000 (psi) |
|--|--------------------------|---------------------|--------------------------|---|--|--|
| Garlock flexible graphite-filled spiral wound gasket (ASME B16.20) | 627                      | 0.35                | 6.22                     | 3,140                                   | 7,040                                    | 11,430                                     |
| Flexible graphite spiral wound gasket                              | 2,300                    | 0.237               | 13                       | 6,851                                   | 11,823                                   | 20,405                                     |
| PTFE-filled spiral wound gasket                                    | 4,500                    | 0.14                | 70                       | 8,575                                   | 11,836                                   | 16,339                                     |
| Foil-reinforced flexible graphite sheet                            | 816                      | 0.377               | 0.066                    | 4,631                                   | 11,033                                   | 26,284                                     |
| Garlock GRAPHONIC® gasket  | 315                      | 0.36                | 1.857                    | 1,653                                   | 3,787                                    | 8,676                                      |
| "Low stress" spiral wound type gasket, flexible graphite filled    | 598                      | 0.385               | 0.03                     | 3,520                                   | 8,540                                    | 14,570                                     |
| Garlock Kammprofile gasket   | 368                      | 0.4                 | 0.28                     | 2,324                                   | 5,838                                    | 14,664                                     |

Comparison of Seating Requirements

\* Gb = stress at which seal is initiated; "a" = the slope of the log/log tightness curve; Gs = intersection of the unload curve with the vertical axis (Tp1)

Note: For a 5" OD gasket at 800 psig, Tp100 = 102ml/min. leakage, Tp1,000 = 1.02ml/min. leakage, Tp10,000 = 0.01 ml/min. leakage.



# The Garlock EDGE®

## Benefits

### Requires lower seating stress

- Seals at lower stress than conventional gaskets without an inner ring
- Eliminates flange damage caused by overtightening
- Relief ports allow tighter seal at lower loads

### Eliminates radial buckling

- STABL-LOCK™ inner wrap construction prevents sealing element from flowing into and contaminating process stream

### Tightest seal

- Modified guide ring ensures contact centered on raised face flange surfaces\*

### Multiple applications

- Available in a dual flange (DF) design to accommodate both 150 and 300 lb flanges—reduces inventory costs
- Select from a wide variety of metallic and filler materials with a full range of temperature capabilities\*\*
- Also available in HEAT SHIELD™ configuration for high temp services above 850°F.

### Seals with lower bolt loads

- Relief tab design provides solid seating of centering ring face
- Withstands bolt load loss caused by thermal cycling
- Inner wrap construction eliminates radial buckling
- Prevents catastrophic failure and potential damage to downstream equipment due to wire unraveling

\* Contact Garlock Engineering when using the EDGE® gasket on lap joint flanges with substandard backing rings.

\*\* See chart on page D-19.

## Compare

Standard spiral wound gasket shows excessive inward buckling

The patented Garlock EDGE® spiral wound gasket is designed to reduce inward buckling

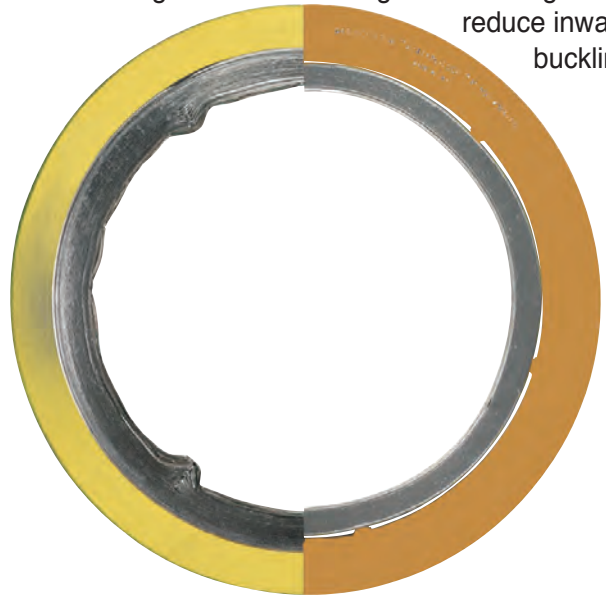

| Gasket Style and Material                                     | "M"  | "Y" (psi) | Gb (psi) | "a" | Gs (psi) |
|---|------|-----------|----------|-----|----------|
| Garlock EDGE® with 304 stainless and flexible graphite filler | 2.00 | 5,000     | 793      | 0.4 | 0.31     |

## Dual Flange (DF) Design

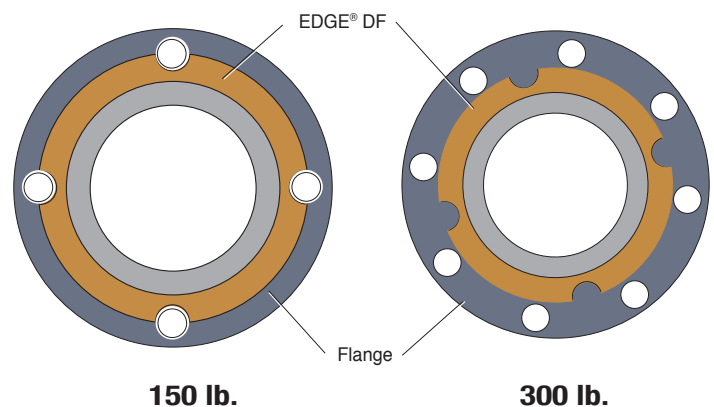

# HEAT SHIELD™ Gasket

## Benefits

### Outstanding fire resistance

- Combination of graphite filler and mica layers give superior fire safety

### Ideal for oxidizing environments

- Layers of pure mica protect graphite filler and resist oxidation
- Good choice for plant steam drums, hydrocarbon catcrackers, hydrogen units, and exhaust manifolds

## Construction

- Heat-resistant graphite filler
- Heat- and oxidation-resistant pure mica filler
- Spiral-wound wires, available in most commercially available metals
- Rings of any standard metal, including INCONEL\* X750

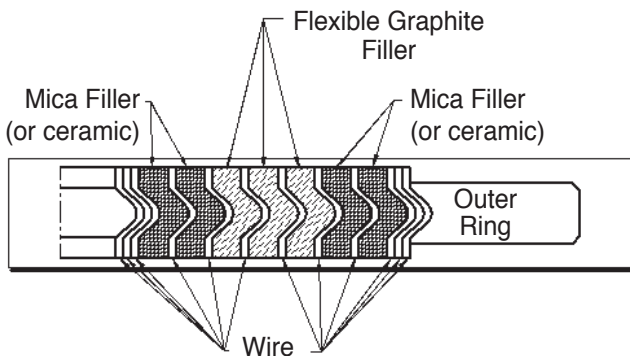

Also available in Kamprofile and EDGE® design

\* INCONEL is a registered trademark of Inco Alloys International, Inc.

## Specifications

Temperature, max.: 1250°F (677°C)  
 Flange class: 150 to 600 lb.  
 Pipe diameters: 2" to 24"; specials available

| Gasket Style and Material                                    | Gasket Factor "M" | Gasket Factor "Y" (psi) |
|--|-------------------|-------------------------|
| Traditional spiral wound gasket—304 SS and flexible graphite | 3.00              | 10,000                  |
| Garlock spiral wound gasket                                  | 3.00              | 7,500                   |

### WARNING:

Properties/applications shown throughout this brochure are typical. Your specific application should not be undertaken without independent study and evaluation for suitability. For specific application recommendations consult Garlock. Failure to select the proper sealing products could result in property damage and/or serious personal injury.

Performance data published in this brochure has been developed from field testing, customer field reports and/or in-house testing.

While the utmost care has been used in compiling this brochure, we assume no responsibility for errors. Specifications subject to change without notice. This edition cancels all previous issues. Subject to change without notice.

# TANDEM SEAL™\*

## Benefits

### Chemical-resistant and fire-safe

- PTFE envelope withstands aggressive chemicals and corrosive media
- Fire-safe—passed independent fire tests
- Two sealing elements significantly reduce corrosion and bacterial contamination of flanges
- Seals to the ID of the pipe bore
- Specify pipe schedule when ordering

## Seal Comparison

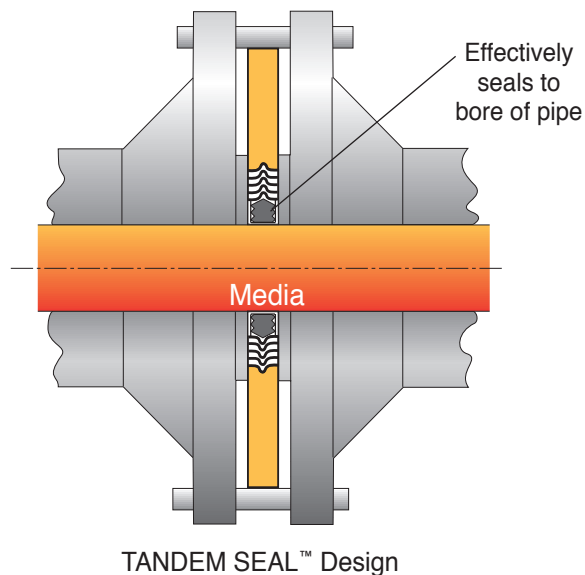
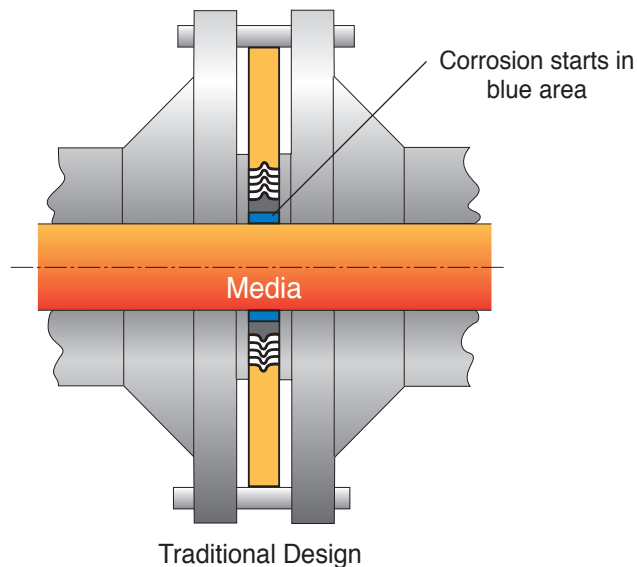

## Standard Construction

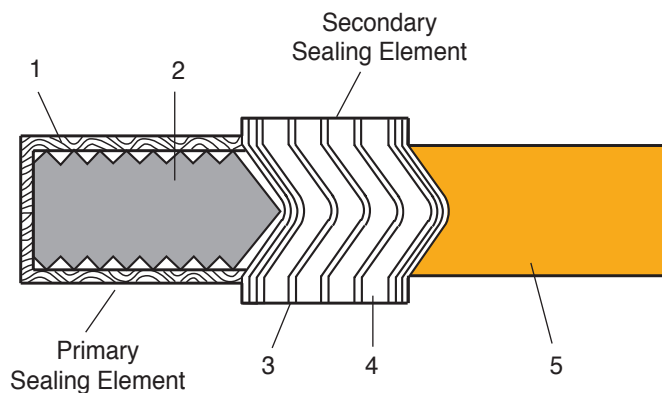

1. PTFE envelope
2. Profiled inner ring
3. Metal windings
4. Filler material
5. Outer guide ring

\* Patent No. 5511797



# FLEXSEAL® RW, RWI and SW Gaskets

## Advantages

- Durable; easy installation and removal
- Seals pressures to flange ratings, in accordance with ASME B16.5
- Suitable for temperatures from cryogenic to 2,000°F (1,093°C)\*
- Guide ring simplifies centering of sealing element on the flange face
- Designed solutions accommodate a variety of conditions by combining various metals and filler materials

## Style RW

- General purpose gasket suitable for flat face and raised face flanges up to Class 2500\*\*
- Centering ring accurately locates the gasket on the flange face, provides additional radial strength, and acts as a compression limiter
- Spiral winding (sealing element) consists of pre-formed metal and soft filler material

## Style RWI

- Suitable for flat face and raised face flanges up to Class 2500\*\*
- Recommended for higher pressure applications, for use with PTFE fillers, and when mandated by ASME B16.20 as follows: NPS 24 and larger in Class 900, NPS 12 and larger in Class 1500, and NPS 4 and larger in Class 2500.
- Inner ring acts as compression limiter and protects sealing elements from process media attack

## Style SW

- Suitable for tongue and groove, male-female, or groove-to-flat face flanges†
- Spiral winding only, containing preformed metal and soft filler material
- Also available with inner rings—Style SWI

\* Consult Garlock Engineering for material recommendations above 850°F (450°C)

\*\* Depending on gasket size, an inner ring is recommended for applications above Class 600, due to the high available bolt load. See also Note 1, page D-22.

† This design does not have a compression limiter.

## Ordering Information

### RW / RWI

When ordering specify:

- Nominal pipe size or specific gasket dimensions
- Winding and filler materials
- Centering and/or inner compression ring material
- Pressure rating

### SW

When ordering, specify:

- O.D. and I.D. dimensions (and tolerance, if other than standard—see page D-19)
- Thickness of gasket
- Winding and filler material
- Inner ring material, if required (Style SWI)
- Pressure rating

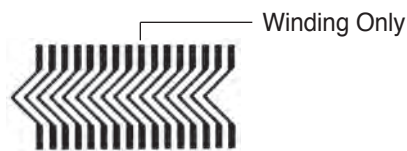
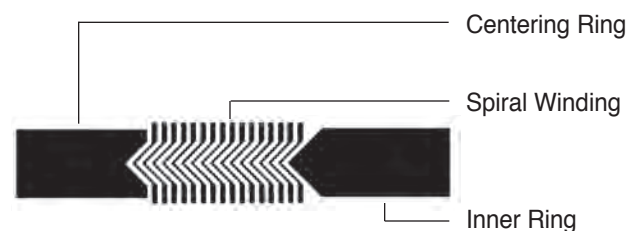
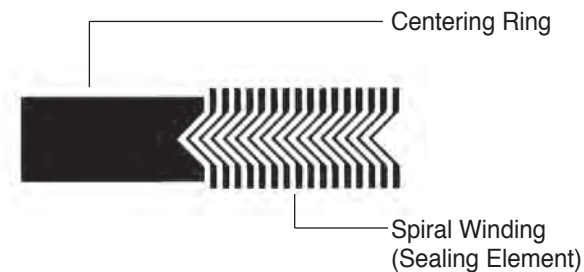

**Note:** For M & Y factors, see page D-33.  
For ROTT Test results, see page D-4.

# FLEXSEAL® MC and MCR Gaskets

## For Manhole Cover Assemblies

### MC Gasket (manhole cover)

- Spiral winding only, containing preformed metal and soft filler material



### MCR Gasket (manhole cover with centering ring)

- Centering ring accurately locates the gasket on the flange face, provides additional radial strength, and acts as a compression limiter
- Spiral winding (sealing element) consists of preformed metal and soft filler material

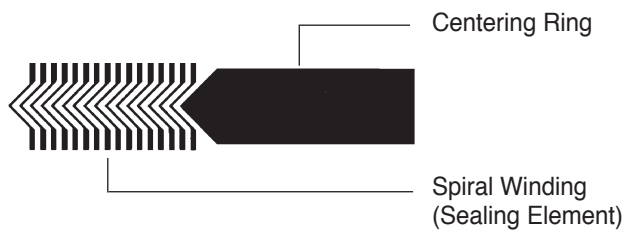

## Ordering Information

When ordering, specify:

- Make and model of boiler and/or equipment if available (See chart page D-10)
- Gasket style and configuration
- Dimensions of gasket (thickness, flange seating width, and shape)
- Maximum operating pressure and temperature
- Type of metal and filler materials

#### WARNING:

Properties/applications shown throughout this brochure are typical. Your specific application should not be undertaken without independent study and evaluation for suitability. For specific application recommendations consult Garlock. Failure to select the proper sealing products could result in property damage and/or serious personal injury.

## MC and MCR Configurations

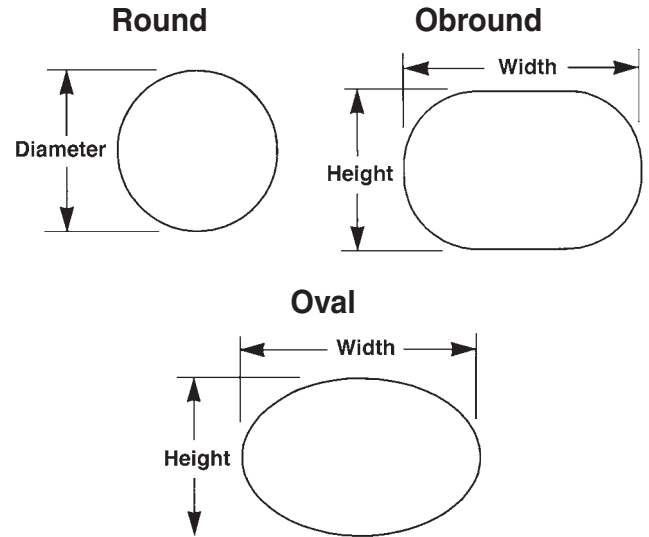

| Style    | Nominal I.D. Dimensions (Inches) | Thickness (Inches) | Flange Width (Inches) |
|----------|----------------------------------|--------------------|-----------------------|
| MC Oval  | 11 x 15                          | 0.175              | 3/4                   |
| MC Oval  | 11 x 15                          | 0.175              | 15/16                 |
| MC Oval  | 11 x 15                          | 0.175              | 1-1/4                 |
| MC Oval  | 12 x 16                          | 0.250              | 15/16                 |
| MCR Oval | 12 x 16                          | 0.250              | 13/16                 |
| MC Oval  | 12 x 16                          | 0.175              | 3/4                   |
| MC Oval  | 12 x 16                          | 0.175              | 15/16                 |
| MC Oval  | 12 x 16                          | 0.175              | 1-1/4                 |
| MC Oval  | 12 x 16                          | 0.250              | 1-1/4                 |
| MC Round | 16-1/16                          | 0.175              | 3/4                   |

*Dimensions of MC and MCR Gaskets*

#### Notes:

1. For pitted and rough flange surfaces, specify a gasket thickness of 0.250".
2. Orders for special cover assemblies should be accompanied by a dimensional drawing showing the minimum width of seating surfaces and other essential dimensions.
3. Style MC oval and obround gaskets are available in 0.175" and 0.250" thickness and in varying widths as shown above.
4. Orders for non-standard gaskets should also include a sketch or drawing of the cover assembly with all dimensions shown.

Performance data published in this brochure has been developed from field testing, customer field reports and/or in-house testing.

While the utmost care has been used in compiling this brochure, we assume no responsibility for errors. Specifications subject to change without notice. This edition cancels all previous issues. Subject to change without notice.

# FLEXSEAL® HH Gaskets

## For Boiler Handhole and Tubecap Assemblies

- Fits most standard boilers (specify maximum operating pressure when ordering)
- Available in thicknesses of 0.125" (special), 0.175" (standard) and 0.250" (special—for pitted surfaces)

## Style HH Configurations

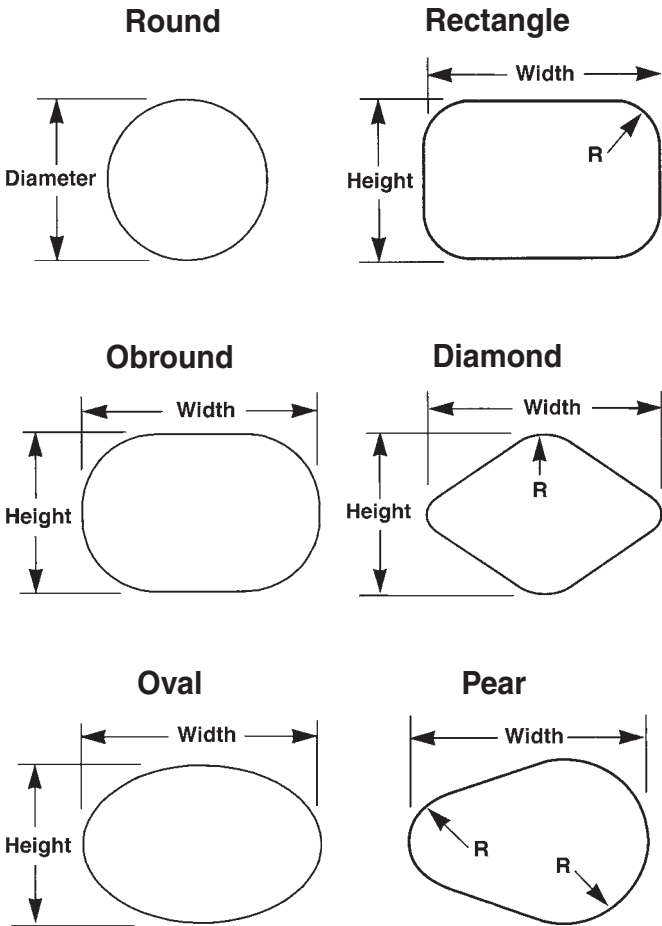

### WARNING:

Properties/applications shown throughout this brochure are typical. Your specific application should not be undertaken without independent study and evaluation for suitability. For specific application recommendations consult Garlock. Failure to select the proper sealing products could result in property damage and/or serious personal injury.

Performance data published in this brochure has been developed from field testing, customer field reports and/or in-house testing.

While the utmost care has been used in compiling this brochure, we assume no responsibility for errors. Specifications subject to change without notice. This edition cancels all previous issues. Subject to change without notice.

## Boiler Gasket Dimensions

| Manufacturer and Model No.     | Shape     | Nominal I.D. Dimensions (Inches) | Flange Width (Inches) |
|--------------------------------|-----------|----------------------------------|-----------------------|
| Babcock and Wilcox #40 (207)   | Diamond   | 3-3/8 x 3-3/4                    | 3/16                  |
| #48 (208)                      | Oval      | 3-13/16 x 4-3/4                  | 7/32                  |
| #24 (211)                      | Oval      | 4-1/2 x 5-1/2                    | 7/32                  |
| #47                            | Round     | 2-1/32                           | 3/16                  |
| #70                            | Round     | 3-9/32                           | 3/16                  |
| #28 (212)                      | Rectangle | 4-13/16 x 5                      | 7/32                  |
| Badenhausen (See Riley Stoker) |           |                                  |                       |
| Cleaver-Brooks                 | Obround   | 3-9/32 x 4-17/32                 | 3/8                   |
| Combustion Engr. 29N-L839      | Diamond   | 3-3/8 x 4-1/4                    | 1/4                   |
| 4N-L740                        | Round     | 3-1/8                            | 1/4                   |
| 5N-L902                        | Round     | 3-5/8                            | 1/4                   |
| Foster Wheeler 2 3/4 (1003)    | Obround   | 2-25/32 x 3-13/32                | 7/32                  |
| 3 15/16 (1005)                 | Oval      | 4-3/16 x 5-3/16                  | 5/16                  |
| Heine                          | Round     | 3-5/8                            | 3/8                   |
| Keeler                         | Obround   | 3 x 4                            | 3/8                   |
| Oilfield                       | Oval      | 3 x 4                            | 3/8                   |
|                                | Oval      | 3-1/2 x 4-1/2                    | 3/8                   |
| Riley Stoker W-C2              | Obround   | 3-23/32 x 5-23/32                | 11/32                 |
| Springfield                    | Oval      | 3-17/32 x 4-17/32                | 5/16                  |
| Union                          | Oval      | 3 x 4                            | 3/8                   |
|                                | Pear      | 4-1/4 x 5-1/4                    | 3/8                   |
| Vogt                           | Oval      | 4-1/4 x 5-1/8                    | 7/32 (new)            |
| Wickes                         |           |                                  |                       |
| D2300                          | Pear      | 4-1/8 x 5-1/8                    | 9/32                  |
| D2301                          | Oval      | 3 x 4                            | 5/16                  |
|                                | Oval      | 3-1/2 x 4-1/2                    | 5/16                  |

## Ordering Information

When ordering, specify:

- Make and model of boiler and/or equipment, if available
- Gasket style and configuration
- Dimensions of gasket (thickness, flange seating width, and shape)
- Maximum operating pressure and temperature
- Type of metal and filler materials

# FLEXSEAL® RW-RJ, RWI-RJ Gaskets

## For Replacement of Ring Joint Gaskets

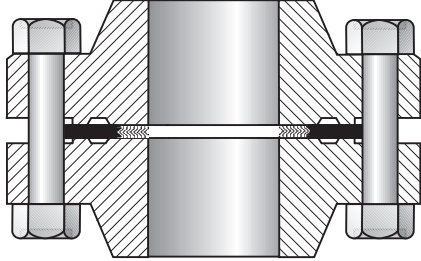

- Ideal replacement for solid metal oval or octagonal API ring joint gaskets (RTJ)
- Saves cost of flange replacement when gasket groove is badly worn
- Fast and easy installation—requires only a 3/16" flange separation (ring joint gasket may require as much as 3/4")
- Wide variety of metal and filler materials have a full range of temperature and pressure capabilities
- RW-RJ gaskets not stocked, but can be special-ordered; RWI-RJ gaskets available on request.

| Nominal Pipe Size (Inches) | 150 psi     |             |           | 300 psi     |             |           | 400 psi     |             |           |
|----------------------------|-------------|-------------|-----------|-------------|-------------|-----------|-------------|-------------|-----------|
|                            | Gasket I.D. | Gasket O.D. | Ring O.D. | Gasket I.D. | Gasket O.D. | Ring O.D. | Gasket I.D. | Gasket O.D. | Ring O.D. |
| 1/2                        | —           | —           | —         | 9/16        | 1-1/16      | 2-1/8     | 9/16        | 1-1/16      | 2-1/8     |
| 3/4                        | —           | —           | —         | 13/16       | 1-5/16      | 2-5/8     | 13/16       | 1-5/16      | 2-5/8     |
| 1                          | 1-1/8*      | 1-5/8*      | 2-5/8*    | 1-1/16      | 1-5/8       | 2-7/8     | 1-1/16      | 1-5/8       | 2-7/8     |
| 1-1/4                      | 1-3/8*      | 1-7/8*      | 3*        | 1-5/16      | 2           | 3-1/4     | 1-5/16      | 2           | 3-1/4     |
| 1-1/2                      | 1-5/8*      | 2-1/4*      | 3-3/8*    | 1-9/16      | 2-3/8       | 3-3/4     | 1-9/16      | 2-3/8       | 3-3/4     |
| 2                          | 2-1/8*      | 2-7/8*      | 4-1/8*    | 2-1/8       | 2-3/4       | 4-3/8     | 2-1/8       | 2-3/4       | 4-3/8     |
| 2-1/2                      | 2-3/4*      | 3-5/16*     | 4-7/8*    | 2-3/4       | 3-5/16      | 5-1/8     | 2-3/4       | 3-5/16      | 5-1/8     |
| 3                          | 3-5/16*     | 3-15/16*    | 5-3/8*    | 3-5/16      | 3-15/16     | 5-7/8     | 3-5/16      | 3-15/16     | 5-7/8     |
| 4                          | 4-5/16*     | 5-3/16*     | 6-7/8*    | 4-5/16      | 5-3/16      | 7-1/8     | 4-5/16      | 5-3/16      | 7         |
| 5                          | 5-5/16*     | 6-3/16*     | 7-3/4*    | 5-5/16      | 6-7/16      | 8-1/2     | 5-5/16      | 6-7/16      | 8-3/8     |
| 6                          | 6-5/16*     | 7-3/16*     | 8-3/4*    | 6-7/16      | 7-5/8       | 9-7/8     | 6-7/16      | 7-5/8       | 9-3/4     |
| 8                          | 8-1/4*      | 9-3/16*     | 11*       | 8-1/4       | 9-15/16     | 12-1/8    | 8-1/4       | 9-15/16     | 12        |
| 10                         | 10-5/16*    | 11-7/16*    | 13-3/8*   | 10-5/16     | 12          | 14-1/4    | 10-5/16     | 12          | 14-1/8    |
| 12                         | 12-3/16*    | 13-9/16*    | 16-1/8*   | 12-7/8†     | 14-1/4†     | 16-5/8†   | 12-7/8†     | 14-1/4†     | 16-1/2†   |
| 14                         | 13-7/16*    | 14-15/16*   | 17-3/4*   | 14-1/4†     | 15-3/4†     | 19-1/8†   | 14-1/4†     | 15-3/4†     | 19†       |
| 16                         | 15-5/16*    | 16-15/16*   | 20-1/4*   | 16-1/4†     | 17-3/4†     | 21-1/4†   | 16-1/4†     | 17-3/4†     | 21-1/8†   |
| 18                         | 17-1/4*     | 19*         | 21-5/8*   | 18-1/4†     | 20-1/4†     | 23-1/2†   | 18-1/4†     | 20-1/4†     | 23-3/8†   |
| 20                         | 19-1/8*     | 21-1/8*     | 23-7/8*   | 20-1/4†     | 22-3/16†    | 25-3/4†   | 20-1/4†     | 22-3/16†    | 25-1/2†   |
| 24                         | 23*         | 25-1/4*     | 28-1/4*   | 24-1/4†     | 26-5/16†    | 30-1/2†   | 24-1/4†     | 26-5/16†    | 30-1/4†   |

| Nominal Pipe Size (Inches) | 600 psi     |             |           | 900 psi     |             |           | 1500 psi    |             |           |
|----------------------------|-------------|-------------|-----------|-------------|-------------|-----------|-------------|-------------|-----------|
|                            | Gasket I.D. | Gasket O.D. | Ring O.D. | Gasket I.D. | Gasket O.D. | Ring O.D. | Gasket I.D. | Gasket O.D. | Ring O.D. |
| 1/2                        | 9/16        | 1-1/16      | 2-1/8     | 9/16*       | 1-1/16*     | 2-1/2*    | 9/16*       | 1-1/16*     | 2-1/2*    |
| 3/4                        | 13/16       | 1-5/16      | 2-5/8     | 13/16*      | 1-3/8*      | 2-3/4*    | 13/16*      | 1-3/8*      | 2-3/4*    |
| 1                          | 1-1/16      | 1-5/8       | 2-7/8     | 1-1/16*     | 1-5/8*      | 3-1/8*    | 1-1/16*     | 1-5/8*      | 3-1/8*    |
| 1-1/4                      | 1-5/16      | 2           | 3-1/4     | 1-5/16*     | 2*          | 3-1/2*    | 1-5/16*     | 2*          | 3-1/2*    |
| 1-1/2                      | 1-9/16      | 2-3/8       | 3-3/4     | 1-9/16*     | 2-3/8*      | 3-7/8*    | 1-9/16*     | 2-3/8*      | 3-7/8*    |
| 2                          | 2-1/8       | 2-3/4       | 4-3/8     | 2-1/4*      | 3-1/4*      | 5-5/8*    | 2-1/4*      | 3-1/4*      | 5-5/8*    |
| 2-1/2                      | 2-3/4       | 3-5/16      | 5-1/8     | 2-9/16*     | 3-5/8*      | 6-1/2*    | 2-9/16*     | 3-5/8*      | 6-1/2*    |
| 3                          | 3-5/16      | 3-15/16     | 5-7/8     | 3-3/16*     | 4-3/16*     | 6-5/8*    | 3-3/16*     | 4-11/16*    | 6-7/8*    |
| 4                          | 4-5/16      | 5-3/16      | 7-5/8     | 4-1/16*     | 5-3/16*     | 8-1/8*    | 4-1/16*     | 5-11/16*    | 8-1/4*    |
| 5                          | 5-5/16      | 6-7/16      | 9-1/2     | 5-5/16      | 6-7/16      | 9-3/4     | 5-1/16*     | 6-15/16*    | 10*       |
| 6                          | 6-7/16      | 7-5/8       | 10-1/2    | 6-5/16      | 7-5/8       | 11-3/8    | 6*          | 7-9/16*     | 11-1/8*   |
| 8                          | 8-1/4       | 9-15/16     | 12-5/8    | 8-1/4       | 9-15/16     | 14-1/8    | 7-7/8*      | 9-3/4*      | 13-7/8*   |
| 10                         | 10-5/16     | 12          | 15-3/4    | 10-5/16     | 12          | 17-1/8    | 9-13/16*    | 11-7/8*     | 17-1/8*   |
| 12                         | 12-7/8†     | 14-1/4†     | 18†       | 12-7/8      | 14-1/4      | 19-5/8    | 11-15/16*   | 13-13/16*   | 20-1/2*   |
| 14                         | 14-1/4†     | 15-3/4†     | 19-3/8†   | 13-13/16    | 15-9/16     | 20-1/2    | 13-7/16     | 15-3/16     | 22-3/4    |
| 16                         | 16-1/4†     | 17-3/4†     | 22-1/4†   | 15-9/16     | 17-9/16     | 22-5/8    | 15          | 17          | 25-1/4    |
| 18                         | 18-1/4†     | 20-1/4†     | 23-3/8†   | 17-11/16    | 19-15/16    | 25-1/8    | 17-1/4      | 19-1/2      | 27-3/4    |
| 20                         | 20-1/4†     | 22-3/16†    | 26-7/8†   | 19-11/16    | 21-15/16    | 27-1/2    | 19-3/16     | 21-7/16     | 29-3/4    |
| 24                         | 24-1/4†     | 26-5/16†    | 31-1/8†   | 23-3/16     | 25-15/16    | 33        | 23          | 25-1/2      | 35-1/2    |

Dimensions for weld neck type flanges having a pipe bore equal to that of schedule 40 pipe and heavier, but not for slip-on flanges; except:

† Both charts: suitable for slip-on and weld neck type flanges

\* Top chart: for weld neck type flanges having a pipe bore equal to that of schedule 40 pipe. Not for slip-on flanges.

\* Bottom chart: for schedule 80 pipe and heavier.

# FLEXSEAL® LMF, LTG and STG Gaskets

## For Male-Female, Tongue and Groove Flanges

- Spiral winding of preformed metal and soft filler material—for use where no space is provided for a compression guide ring
- Inner diameter of windings is reinforced with several plies of metal without filler to give greater stability
- Style LMF — large male-female flanges  
Style LTG — large tongue and groove flanges  
Style STG — small tongue and groove flanges

## Applications

- Valves
- Pumps
- Flanges
- Heat exchangers
- Vessels

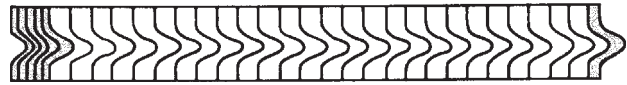

Cross Sectional View of Winding

## Ordering Information

When ordering, specify:

- Nominal pipe size
- Pressure rating
- Winding materials (304 SS is standard, filler material must be specified)
- Thickness of winding (0.125" is standard)

## Style LMF Gasket Dimensions

| Nominal<br>Pipe Size<br>(Inches) | 150 - 1500 psi   |                  | Nominal<br>Pipe Size<br>(Inches) | 2500 psi         |                  |
|----------------------------------|------------------|------------------|----------------------------------|------------------|------------------|
|                                  | I.D.<br>(Inches) | O.D.<br>(Inches) |                                  | I.D.<br>(Inches) | O.D.<br>(Inches) |
| 1/4                              | 1/2              | 1                | 1/2                              | 13/16            | 1-3/8            |
| 1/2                              | 1                | 1-3/8            | 3/4                              | 1-1/16           | 1-11/16          |
| 3/4                              | 1-5/16           | 1-11/16          | 1                                | 1-1/4            | 2                |
| 1                                | 1-1/2            | 2                | 1-1/4                            | 1-5/8            | 2-1/2            |
| 1-1/4                            | 1-7/8            | 2-1/2            | 1-1/2                            | 1-7/8            | 2-7/8            |
| 1-1/2                            | 2-1/8            | 2-7/8            | 2                                | 2-3/8            | 3-5/8            |
| 2                                | 2-7/8            | 3-5/8            | 2-1/2                            | 3                | 4-1/8            |
| 2-1/2                            | 3-3/8            | 4-1/8            | 3                                | 3-3/4            | 5                |
| 3                                | 4-1/4            | 5                | 3-1/2                            | —                | —                |
| 3-1/2                            | 4-3/4            | 5-1/2            | 4                                | 4-3/4            | 6-3/16           |
| 4                                | 5-3/16           | 6-3/16           | 5                                | 5-3/4            | 7-5/16           |
| 4-1/2                            | 5-11/16          | 6-3/4            | 6                                | 6-3/4            | 8-1/2            |
| 5                                | 6-5/16           | 7-5/16           | 8                                | 8-3/4            | 10-5/8           |
| 6                                | 7-1/2            | 8-1/2            | 10                               | 10-3/4           | 12-3/4           |
| 8                                | 9-3/8            | 10-5/8           | 12                               | 13               | 15               |
| 10                               | 11-1/4           | 12-3/4           |                                  |                  |                  |
| 12                               | 13-1/2           | 15               |                                  |                  |                  |
| 14                               | 14-3/4           | 16-1/4           |                                  |                  |                  |
| 16                               | 17               | 18-1/2           |                                  |                  |                  |
| 18                               | 19-1/4           | 21               |                                  |                  |                  |
| 20                               | 21               | 23               |                                  |                  |                  |
| 24                               | 25-1/4           | 27-1/4           |                                  |                  |                  |

## Style LTG Dimensions

| Nominal<br>Pipe Size<br>(Inches) | 150 - 2500 psi   |                  |
|----------------------------------|------------------|------------------|
|                                  | I.D.<br>(Inches) | O.D.<br>(Inches) |
| 1/2                              | 1                | 1-3/8            |
| 3/4                              | 1-5/16           | 1-11/16          |
| 1                                | 1-1/2            | 2                |
| 1-1/4                            | 1-7/8            | 2-1/2            |
| 1-1/2                            | 2-1/8            | 2-7/8            |
| 2                                | 2-7/8            | 3-5/8            |
| 2-1/2                            | 3-3/8            | 4-1/8            |
| 3                                | 4-1/4            | 5                |
| 3-1/2                            | 4-3/4            | 5-1/2            |
| 4                                | 5-3/16           | 6-3/16           |
| 5                                | 6-5/16           | 7-5/16           |
| 6                                | 7-1/2            | 8-1/2            |
| 8                                | 9-3/8            | 10-5/8           |
| 10                               | 11-1/4           | 12-3/4           |
| 12                               | 13-1/2           | 15               |
| 14                               | 14-3/4           | 16-1/4           |
| 16                               | 17               | 18-1/2           |
| 18                               | 19-1/4           | 21               |
| 20                               | 21               | 23               |
| 24                               | 25-1/4           | 27-1/4           |

## Style STG Dimensions

| Nominal<br>Pipe Size<br>(Inches) | 150 - 2500 psi   |                  |
|----------------------------------|------------------|------------------|
|                                  | I.D.<br>(Inches) | O.D.<br>(Inches) |
| 1/2                              | 1                | 1-3/8            |
| 3/4                              | 1-5/16           | 1-11/16          |
| 1                                | 1-1/2            | 1-7/8            |
| 1-1/4                            | 1-7/8            | 2-1/4            |
| 1-1/2                            | 2-1/8            | 2-1/2            |
| 2                                | 2-7/8            | 3-1/4            |
| 2-1/2                            | 3-3/8            | 3-3/4            |
| 3                                | 4-1/4            | 4-5/8            |
| 3-1/2                            | 4-3/4            | 5-1/8            |
| 4                                | 5-3/16           | 5-11/16          |
| 5                                | 6-5/16           | 6-13/16          |
| 6                                | 7-1/2            | 8                |
| 8                                | 9-3/8            | 10               |
| 10                               | 11-1/4           | 12               |
| 12                               | 13-1/2           | 14-1/4           |
| 14                               | 14-3/4           | 15-1/2           |
| 16                               | 16-3/4           | 17-5/8           |
| 18                               | 19-1/4           | 20-1/8           |
| 20                               | 21               | 22               |
| 24                               | 25-1/4           | 26-1/4           |

### WARNING:

Properties/applications shown throughout this brochure are typical. Your specific application should not be undertaken without independent study and evaluation for suitability. For specific application recommendations consult Garlock. Failure to select the proper sealing products could result in property damage and/or serious personal injury.

Performance data published in this brochure has been developed from field testing, customer field reports and/or in-house testing.

While the utmost care has been used in compiling this brochure, we assume no responsibility for errors. Specifications subject to change without notice. This edition cancels all previous issues. Subject to change without notice.



# Exchanger and Vessel Gaskets

Garlock manufactures a wide variety of solid metal, metal clad, and metal core gaskets. Among the most requested styles are double-jacketed gaskets, Kamm-profile, corrugated gaskets, and solid metal gaskets, all available in a choice of metals and filler materials.

Custom configurations of heat exchanger gaskets are also available. Spiral windings can be designed with or without partitions welded to the winding, or inner and outer rings with welded partitions. Contact Garlock for all of your heat exchanger and vessel gasket needs.

## Garlock Heat Exchanger Gasket Configurations

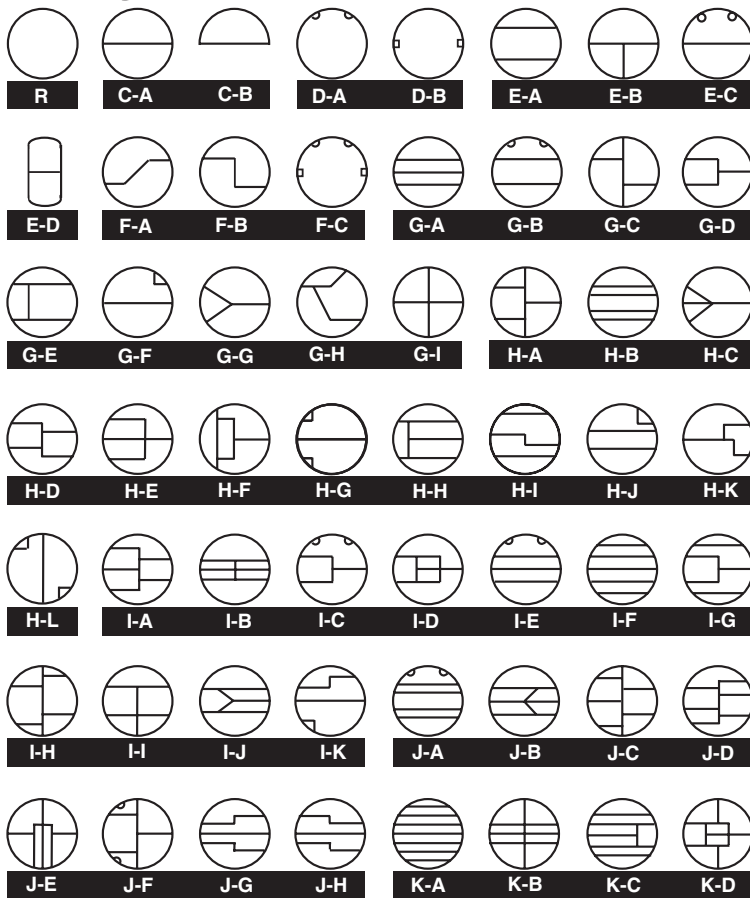

## Tolerances

| Gasket Outside Diameter | Inside Diameter Tolerance | Outside Diameter Tolerance |
|-------------------------|---------------------------|----------------------------|
| Up to 36"               | +1/16" / -0               | +0 / -1/16"                |
| 36" and above           | +1/8" / -0                | +0 / -1/8"                 |

Thickness:  $\pm 1/32"$   
Rib Width:  $\pm 1/64"$

Radii:  $\pm 1/16"$   
Rib Location:  $\pm 1/16"$

## Gasket Widths

| Gasket Diameter | Minimum Width (Gasket and Ribs) | Maximum Width |
|-----------------|---------------------------------|---------------|
| Up to 12"       | 3/16"                           | *             |
| Over 12"        | 1/4"                            | *             |

\* **Note:** There is no maximum width for heat exchanger gaskets.

# Series 600 Metal-Clad Gaskets

## Gasket Styles

### Style 600—Corrugated Solid Metal

A plain, all-metal corrugated gasket for use in low pressure applications that require a thin line contact because of space or weight limitations. Corrugated gaskets are a versatile sealing element where the available bolt loads are low.



### Style 606—Solid Metal with Flexible Graphite Covering

A solid metal gasket covered with a layer of flexible graphite. This covering layer seals at a low load and fills voids and imperfections in the flange.

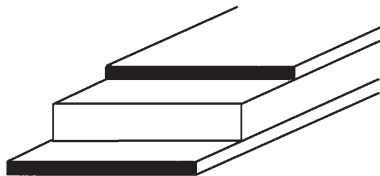

### Style 620—Single-Jacketed

Generally used where the radial dimensions of the equipment sealing surfaces only allow space for a narrow width seal. Single-jacketed gaskets are constructed as shown. The metal jacket reinforces the soft sealing material.

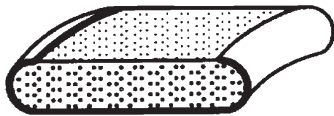

### Style 623—Double-Jacketed

The double-jacketed gasket has good compressibility and resilience and is the most popular metal-clad gasket manufactured.



### Style 624—Single-Jacketed Overlap

Construction of this gasket offers more filler protection than the standard single-jacketed design. Although constructed like a single-jacketed gasket, it has the added benefit of totally encasing the filler material.

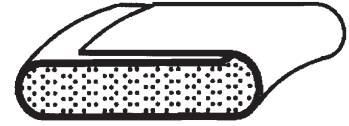

### Style 626—Double-Jacketed Corrugated

Concentric corrugated sealing element totally encapsulates the soft filler material. The corrugations give improved resilience in applications where thermocycling is a problem.

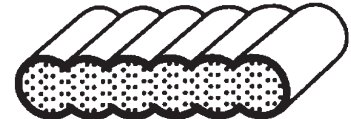

### Style 627—Double Shell

The double shell on this gasket allows greater hoop strength and rigidity with the addition of a completely overlapping inner seal. This gasket will withstand higher compressive loads common in high pressure applications.



### Style 629—Double-Jacketed Corrugated with Corrugated Metal Filler

The metal filler in Style 629 has greater resilience to problems resulting from thermocycling. The temperature limits of this gasket are governed only by the metal selected.



# Series 600 Gasket Styles

## Style 631—Two-Piece French-Type

Garlock Style 631 is ideal for narrow circular applications that require a positive unbroken metal gasket line across the full width of the flange. The filler is exposed on the OD. This gasket is also available in one, two, and three-piece constructions.



## Style 635—Selected Metal and CERAFELT®\*

This gasket is designed to be used in lightweight flanges. The thick compressible layer of CERAFELT® is shielded on the ID with a metallic barrier. Style 635 is commonly used in applications with very hot gases and low pressures.

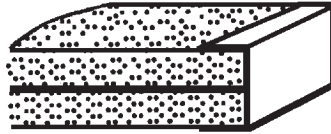

## Style 640—Solid Metal

This gasket offers extremely tight sealing, high mechanical strength, and good resistance to temperature, corrosion and pressure. Bolting stress and flange surface finish are key to the performance of this design.



## Style 641—Solid Metal Profile

Profile gaskets combine the desirable qualities of a solid metal gasket with the advantages of a reduced area of contact, thereby reducing the bolt stress required to effect a seal. This gasket has the same advantages of strength, heat conductivity, and resistance to temperature, pressure and corrosion as Garlock Style 640.

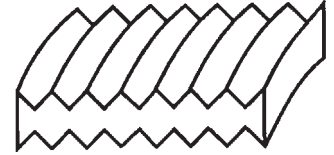

## Style 642—Grooved Metal

See Kammprofile, page D-17.

## Styles 644 and 645—Single- and Double-Jacketed Profile

Metal-jacketed profile gaskets employ the same principle of reduced contact area while protecting the flange faces from damage due to scoring. This gasket can be manufactured in one of two designs—either single-jacketed (Style 644) or double-jacketed (Style 645).



CERAFELT® is a registered trademark of Thermal Ceramics.

### WARNING:

Properties/applications shown throughout this brochure are typical. Your specific application should not be undertaken without independent study and evaluation for suitability. For specific application recommendations consult Garlock. Failure to select the proper sealing products could result in property damage and/or serious personal injury.

Performance data published in this brochure has been developed from field testing, customer field reports and/or in-house testing.

While the utmost care has been used in compiling this brochure, we assume no responsibility for errors. Specifications subject to change without notice. This edition cancels all previous issues. Subject to change without notice.

# GRAPHONIC® Metallic Gasket

The superior technology of the GRAPHONIC® family of gaskets ensures excellent sealing performance and reliability, even in the most difficult applications. Each of the three styles combines a corrugated metal core with a compressible sealing element of various materials, for resistance to a wide range of harsh conditions, including extreme temperature, corrosive chemicals, and thermal cycling.

## Applications

- Valves
- Pumps
- Flanges
- Heat exchangers
- Vessels

## GRAPHONIC® Gasket (Style 603)

With flexible graphite sealing element

- Accommodates a wide range of temperatures
- Seals effectively during thermal cycling
- Fire safe—passed API 6FB fire tests
- Chemically resistant
- Long service life

## TEPHONIC® Gasket (Style 604)

With ePTFE sealing element

- Chemically inert
- Forms a tight seal under low bolt load
- Conforms to minor sealing surface imperfections
- Withstands temperatures to 500°F (260°C)

## G.E.T.™ Gasket (Style 607)

With graphite and ePTFE sealing element

- Combines fire safety with chemical resistance
- Conforms to minor sealing surface imperfections
- Rigid yet compressible

INCONEL® is a registered trademark of Inco Alloys International, Inc.  
 INCOLOY® is a registered trademark of Inco Alloys International, Inc.  
 HASTELLOY® is a registered trademark of Haynes International.  
 MONEL® is a registered trademark of International Nickel.



## Construction

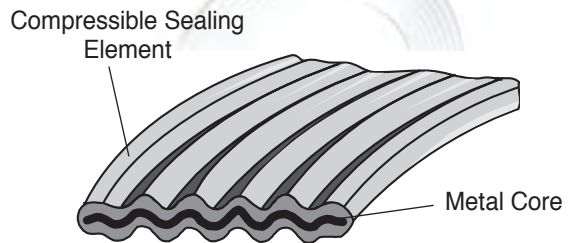

### Standard Metals

- 316L Stainless

### Also Available

- 304 Stainless
- Carbon steel
- INCONEL® 600
- INCONEL® 625
- INCOLOY® 800
- INCOLOY® 825
- HASTELLOY® C276
- MONEL® 400

### Sealing Elements

- Flexible graphite
- ePTFE
- Combination graphite and ePTFE

## Engineering Data

|                     | GRAPHONIC®          | TEPHONIC®<br>and G.E.T.™ |
|---------------------|---------------------|--------------------------|
| Temperature,        |                     |                          |
| Minimum:            | -400°F (-240°C)     | -400°F (-240°C)          |
| Max. in atmosphere: | 850°F (454°C)       | 500°F (260°C)            |
| Max. in steam:      | 1,200°F (650°C)     | 500°F (260°C)            |
| Max. continuous:    | 850°F (454°C)       | 500°F (260°C)            |
| Pressure, max.:     | 1,000 psig (70 bar) |                          |
| P x T, max.         |                     |                          |
| 1/16" thickness:    | 700,000 (25,000)†   | —                        |
| 1/8" thickness:     | 400,000 (13,500)    | 250,000 (8,500)          |

† P x T max. = psig x °F (bar x °C)

**Note:** When approaching maximum temperatures, consult the Garlock Metallic Gasket Engineering Dept. at **1-800-972-7638** or **1-281-459-7200**.

# Garlock Kammprofile™ Gasket

## Benefits

- Accommodates standard ASME flanges as well as weaker and non-circular flanges
- Seals less-than-perfect flanges
- Handles pressures from vacuum to Class 2500
- Performance replacement for jacketed heat exchanger gaskets
- Fire safe—passed API 6FB fire tests
- Available in heat shield configuration for high temp applications above 850°F (454°C) (see page D-6)

## Applications

- Valves
- Pumps
- Flanges
- Heat exchangers
- Vessels

### Serrated solid metal core

- Solid metal core resists cold flow, overcompression and blowout
- Rigid core provides exceptional stability, even in large sizes, and facilitates handling and installation
- Available in wide variety of metals

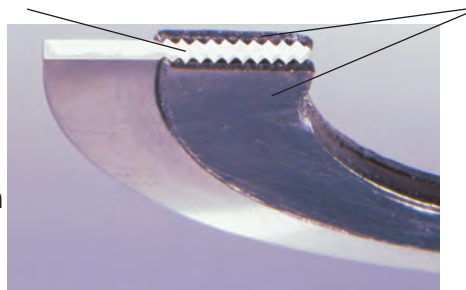

### Soft, deformable sealing material

- Under compression, fills seating surface imperfections to form a tight connection
- Seals under low stress—ideal for weaker flanges
- Withstands extreme fluctuations in temperatures and pressures

## Style Selection Guide

| Garlock Kammprofile Styles | Construction  |             | Centering Ring |          | Flange      |               |           |             |
|----------------------------|---------------|-------------|----------------|----------|-------------|---------------|-----------|-------------|
|                            | Parallel Root | Convex Root | Ring           |          | Male/Female | Tongue/Groove | Flat Face | Raised Face |
|                            |               |             | Integral       | Floating |             |               |           |             |
| 642 A                      | ●             |             |                |          | ●           | ●             |           | ●           |
| 642 AR                     | ●             |             | ●              |          |             |               | ●         | ●           |
| 642 AR2                    | ●             |             |                | ●        |             |               | ●         | ●           |
| 642 AC                     |               | ●           |                |          | ●           | ●             |           | ●           |
| 642 ARC                    |               | ●           | ●              |          |             |               | ●         | ●           |
| 642 ARC2                   |               | ●           |                | ●        |             |               | ●         | ●           |

- **Parallel root core** is standard design
- **Convex root core** compensates for weaker flanges and resulting flange rotation
- **Integral centering ring** ensures optimum gasket positioning
- **Floating centering ring** allows for expansion and contraction during thermal cycling

| Gasket Style       | Gasket Factor "M" | Gasket Factor "Y" (psi) |
|--------------------|-------------------|-------------------------|
| Kammprofile gasket | 4.00              | 1,000*                  |

**Note:** When designing a flange, a "Y" value of 4,000 psi is suggested.

### WARNING:

Properties/applications shown throughout this brochure are typical. Your specific application should not be undertaken without independent study and evaluation for suitability. For specific application recommendations consult Garlock. Failure to select the proper sealing products could result in property damage and/or serious personal injury.

Performance data published in this brochure has been developed from field testing, customer field reports and/or in-house testing.

While the utmost care has been used in compiling this brochure, we assume no responsibility for errors. Specifications subject to change without notice. This edition cancels all previous issues. Subject to change without notice.



# Factors Affecting Gasket Performance

A gasket is any deformable material which, when clamped between essentially stationary faces, prevents the passage of media across the gasketed connection.

Compressing the gasket material causes the material to flow into the imperfections of the sealing areas and effect a seal. This seal prevents the escape of the contained media. In order to maintain this condition, sufficient load must be applied to the connection to oppose the hydrostatic end force created by the internal pressure of the system.

Gasket performance depends on a number of factors, including:

1. **Gasket Metal and Filler Material:** The materials must withstand the effects of:
  - a. **Temperature:** Temperature can adversely affect mechanical and chemical properties of the gasket, as well as physical characteristics such as oxidation and resilience.
  - b. **Pressure:** The media or internal piping pressure can blow out the gasket across the flange face.
  - c. **Media:** The gasket materials must be resistant to corrosive attack from the media.

2. **Joint Design:** The force holding the two flanges together must be sufficient to prevent flange separation caused by hydrostatic end force, resulting from the pressure acting on the internal area.
3. **Proper Bolt Load:** If the bolt load is insufficient to deform the gasket, or is so excessive that it crushes the gasket, a leak will occur.
4. **Surface Finish:** If the surface finish is not suitable for the gasket, a seal will not be effected.

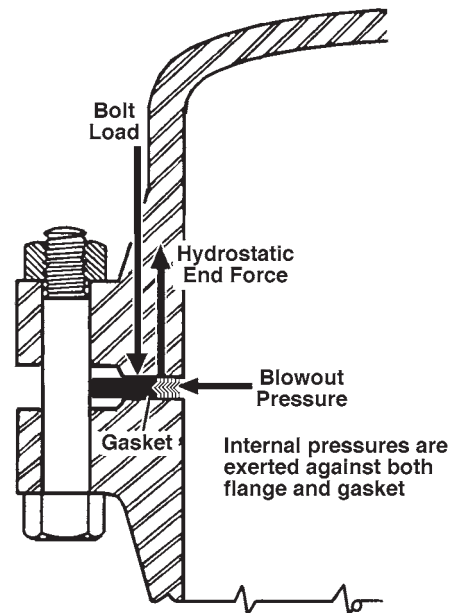

Forces Acting on a Gasket

## WARNING:

Properties/applications shown throughout this brochure are typical. Your specific application should not be undertaken without independent study and evaluation for suitability. For specific application recommendations consult Garlock. Failure to select the proper sealing products could result in property damage and/or serious personal injury.

Performance data published in this brochure has been developed from field testing, customer field reports and/or in-house testing.

While the utmost care has been used in compiling this brochure, we assume no responsibility for errors. Specifications subject to change without notice. This edition cancels all previous issues. Subject to change without notice.

# Spiral Wound Specifications

## Temperature Limits for Common Metals

| Material             | Minimum |      | Maximum |       | Abbreviation |
|----------------------|---------|------|---------|-------|--------------|
|                      | °F      | °C   | °F      | °C    |              |
| 304 Stainless Steel  | -320    | -195 | 1,400   | 760   | 304          |
| 316L Stainless Steel | -150    | -100 | 1,400   | 760   | 316L         |
| 317L Stainless Steel | -150    | -100 | 1,400   | 760   | 317L         |
| 321 Stainless Steel  | -320    | -195 | 1,400   | 760   | 321          |
| 347 Stainless Steel  | -320    | -195 | 1,700   | 925   | 347          |
| Carbon Steel         | -40     | -40  | 1,000   | 540   | CRS          |
| 20Cb-3 (Alloy 20)    | -300    | -185 | 1,400   | 760   | A-20         |
| HASTELLOY® B 2       | -300    | -185 | 2,000   | 1,090 | HAST B       |
| HASTELLOY® C 276     | -300    | -185 | 2,000   | 1,090 | HAST C       |
| INCOLOY® 800         | -150    | -100 | 1,600   | 870   | IN 800       |
| INCOLOY® 825         | -150    | -100 | 1,600   | 870   | IN 825       |
| INCONEL® 600         | -150    | -100 | 2,000   | 1,090 | INC 600      |
| INCONEL® 625         | -150    | -100 | 2,000   | 1,090 | INC 625      |
| INCONEL® X750        | -150    | -100 | 2,000   | 1,090 | INX          |
| MONEL® 400           | -200    | -130 | 1,500   | 820   | MON          |
| Nickel 200           | -320    | -195 | 1,400   | 760   | NI           |
| Titanium             | -320    | -195 | 2,000   | 1,090 | TI           |

| Guide Ring Color Code* |
|------------------------|
| Yellow                 |
| Green                  |
| Maroon                 |
| Turquoise              |
| Blue                   |
| Silver                 |
| Black                  |
| Brown                  |
| Beige                  |
| White                  |
| White                  |
| Gold                   |
| Gold                   |
| No Color               |
| Orange                 |
| Red                    |
| Purple                 |

## Temperature Limits for Filler Material

| Material          | Minimum |      | Maximum COT |       | Abbreviation |
|-------------------|---------|------|-------------|-------|--------------|
|                   | °F      | °C   | °F          | °C    |              |
| Ceramic†          | -350    | -212 | 2,000       | 1,090 | CER          |
| Flexible Graphite | -350    | -212 | 850         | 454   | F.G.         |
| PTFE              | -400    | -240 | 500         | 260   | PTFE         |

| Stripe Color Code* |
|--------------------|
| Light Green        |
| Gray               |
| White              |

## Standard Tolerances

For windings

| Gasket Diameter | ID          | OD          |
|-----------------|-------------|-------------|
| Up to 1"        | " +1/64" -0 | " +0 -1/32" |
| 1" to 24"       | " +1/32" -0 | " +0 -1/32" |
| 24" to 36"      | " +3/64" -0 | " +0 -1/16" |
| 36" to 60"      | " +1/16" -0 | " +0 -1/16" |
| 60" and above   | " +3/32" -0 | " +0 -3/32" |

For spiral wound gaskets not otherwise specified.

| Gasket    |           | Width Limits |          | Compressed Thickness |
|-----------|-----------|--------------|----------|----------------------|
| Thickness | Tolerance | Minimum      | Maximum  |                      |
| 0.125"*** | ±0.005"   | 3/16"        | 1"††     | 0.090 - 0.100"       |
| 0.175"*** | ±0.005"   | 1/4"         | 1-1/2"†† | 0.125 - 0.135"       |
| 0.250"*** | ±0.005"   | 5/16"        | 1-1/2"†† | 0.180 - 0.200"       |
| 0.285"*** | ±0.005"   | 5/16"        | 1-1/2"†† | 0.200 - 0.220"       |

## Available Thicknesses

| Winding | Ring(s) Inner & Outer |
|---------|-----------------------|
| 0.125"  | 3/32"                 |
| 0.175"  | 1/8"                  |
| 0.250"  | 3/16"                 |
| 0.285"  | 3/16"                 |

HASTELLOY® is a registered trademark of Haynes International.  
 INCOLOY® and INCONEL® are registered trademarks of Inco Alloys International, Inc.  
 MONEL® is a registered trademark of International Nickel.

### Note:

Thickness tolerance is ±0.005" on all gaskets, except +0.010" -0.005" on gaskets with:

- Less than 1" ID and greater than 26" ID
- PTFE filler
- Flange widths of 1" or greater

\* ASME B 16.20 standard

† Contact Garlock Engineering when selecting this material.

\*\* Measured across the metallic portion of the gasket not including the filler, which may protrude slightly.

†† Spiral wound gaskets can be made to large maximum widths if required. Call Garlock for details.

# Flange Types

## Flat Face

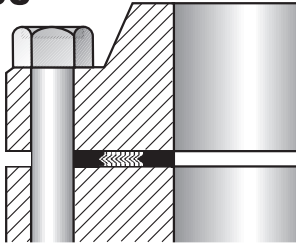

### Unconfined Gasket

- Mating faces of both flanges are flat
- Gasket may be ring type, or full face, which covers the entire face both inside and outside the bolts

## Raised Face

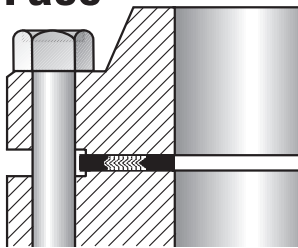

### Unconfined Gasket

- Flange sealing surface is reduced to achieve higher seating stress
- Gasket is usually ring type, contained entirely within bolts

## Ring Joint

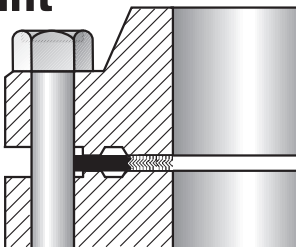

### Also Called "API Joint" or "RTJ"

- Both flange faces have matching flat-bottomed grooves with sides tapered from the vertical at 23°
- Gasket seats on flat section of flange between bore and ring joint groove
- Garlock spiral wound gaskets can replace solid metal ring gaskets

## Male-Female

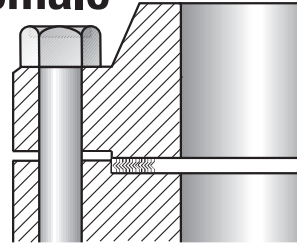

### Semi-Confined Gasket

- Depth of female (recessed) face normally equal to or less than height of male (raised) face, to prevent metal-to-metal contact during gasket compression
- Recessed O.D. normally is not more than 1/16" larger than the O.D. of the male face
- Joint must be pried apart for disassembly

## Tongue and Groove

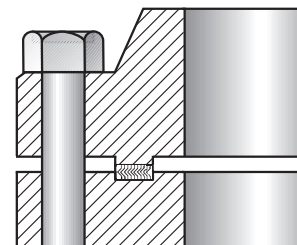

### Fully Confined Gasket

- Groove depth is equal to or less than tongue height
- Groove usually not over 1/16" wider than tongue
- Gasket dimensions will match tongue dimensions
- Joint must be pried apart for disassembly

## Groove to Flat

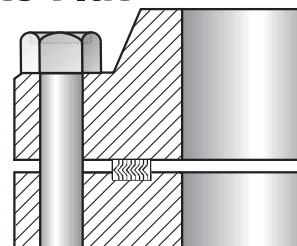

### Fully Confined Gasket

- One flange face is flat, the other is recessed
- For applications requiring accurate control of gasket compression
- Only resilient gaskets are recommended—spiral wound, hollow metal O-ring, pressure-actuated, and metal-jacketed gaskets

# Gasket Selection By Flange Type

|                 | RW | RWI | EDGE® | TANDEM | SW | MC | MCR | HH | RW-RJ | RWI-RJ | LMF | LTG | STG | HEAT SHIELD™ |
|-----------------|----|-----|-------|--------|----|----|-----|----|-------|--------|-----|-----|-----|--------------|
| Flat Face       | ■  | ■   | ■     | ■      |    | ■  | ■   | ■  |       |        |     |     |     | ■            |
| Raised Face     | ■  | ■   | ■     | ■      |    |    | ■   |    |       |        |     |     |     | ■            |
| Ring Joint      |    |     |       |        |    |    |     |    | ■     | ■      |     |     |     |              |
| Male-Female     |    |     |       |        | ■  | ■  |     |    |       |        | ■   | ■   | ■   |              |
| Tongue-&-Groove |    |     |       |        | ■  | ■  |     |    |       |        |     | ■   | ■   |              |
| Groove-to-Flat  |    |     |       |        | ■  | ■  |     |    |       |        |     |     |     |              |

## Flange Surface Finish

The surface finish of a flange is described as follows:

### Roughness

- Average of peaks and valleys measured from mid-line of flange surface (in millionths of an inch)
- Expressed as rms (root mean square) or AA (arithmetic average) or AARH (arithmetic average roughness height)

### Lay

- The direction of the predominant surface-roughness pattern
- Example: multidirectional, phonographic spiral serrations, etc.

### Waviness

- The departure from overall flatness
- Measured in thousandths or fractions of an inch

## Recommended Values

|                                      |             |
|--------------------------------------|-------------|
| Spiral Wound Gaskets .....           | 125-250 rms |
| GRAPHONIC® Gaskets .....             | 125-250 rms |
| Kammprofile Gaskets .....            | 125-250 rms |
| Jacketed or Metal Clad Gaskets ..... | 63-80 rms   |
| Solid Metal Gaskets .....            | 63-80 rms   |

### Note:

These values are suggested only and not mandatory; however they are based upon the best cross-section of successful design experience currently available.

### WARNING:

Properties/applications shown throughout this brochure are typical. Your specific application should not be undertaken without independent study and evaluation for suitability. For specific application recommendations consult Garlock. Failure to select the proper sealing products could result in property damage and/or serious personal injury.

Performance data published in this brochure has been developed from field testing, customer field reports and/or in-house testing.

While the utmost care has been used in compiling this brochure, we assume no responsibility for errors. Specifications subject to change without notice. This edition cancels all previous issues. Subject to change without notice.

# Maximum Flange Bore for FLEXSEAL® RW Gaskets

| Flange Size (NPS) | Pressure Class                      |   |  |  |   |   |                             |                               |
|-------------------|-------------------------------------|---|--|--|---|---|-----------------------------|-------------------------------|
|                   | 75                                  | 150   | 300  | 400  | 600   | 900 <sup>1</sup>  | 1500 <sup>1</sup>           | 2500 <sup>1</sup>             |
| 1/2"              | No recommendation in 75 lb. flanges | Weld-neck only <sup>2</sup>                 |  | No flanges. Use Class 600  | Weld-neck only <sup>2</sup>                 | No flanges. Use Class 1500  | Weld-neck only <sup>2</sup> |                               |
| 3/4"              |                                     |   |  |  | Weld-neck only <sup>2</sup>                 |   |                             |                               |
| 1"                |                                     | Slip-on <sup>3</sup> Weld-neck <sup>2</sup> |  |  | Slip-on <sup>3</sup> Weld-neck <sup>2</sup> |   |                             |                               |
| 1 1/4"            |                                     |   |  |  | Slip-on <sup>3</sup> Weld-neck <sup>2</sup> |   |                             |                               |
| 1 1/2"            |                                     | Slip-on <sup>3</sup> Weld-neck, any bore    |  | Slip-on, Weld-neck, any bore   | Slip-on <sup>3</sup> Weld-neck, any bore    |   |                             |                               |
| 2"                |                                     |   |  |  | Slip-on <sup>3</sup> Weld-neck, any bore    |   |                             |                               |
| 2 1/2"            |                                     | Slip-on, Weld-neck, any bore                |  | Weld-neck with Schedule 10S bore described in ASME B36.19M (includes nozzle <sup>4</sup> but excludes Slip-on)     | Slip-on, Weld-neck, any bore                | Weld-neck with Standard wall bore (includes nozzle <sup>4</sup> but excludes Slip-on) |                             |                               |
| 3"                |                                     |   |  |  | Slip-on, Weld-neck, any bore                |   |                             |                               |
| 4"                |                                     |   |  |  | Slip-on, Weld-neck, any bore                |   |                             |                               |
| 6"                |                                     |   |  |  | Slip-on, Weld-neck, any bore                |   |                             | Weld-neck w/ Schedule 60 bore |
| 8"                |                                     | Slip-on, Weld-neck, any bore                |  | Weld-neck with Schedule 10 bore described in ASME B36.10M (excludes nozzle <sup>4</sup> and Slip-on <sup>5</sup> ) | Slip-on, Weld-neck, any bore                | Weld-neck w/ Schedule 80 bore   | No flanges                  |                               |
| 10"               |                                     |   |  |  | Slip-on, Weld-neck, any bore                | Weld-neck w/ Schedule 80 bore   |                             |                               |
| 12"               |                                     |   |  |  | Slip-on, Weld-neck, any bore                | Weld-neck w/ Standard wall bore (excludes nozzle and Slip-on)                         |                             |                               |
| 14"               |                                     |   |  |  | Slip-on, Weld-neck, any bore                | Weld-neck w/ Standard wall bore (excludes nozzle and Slip-on)                         |                             |                               |
| 16"               | Slip-on, Weld-neck, any bore        |   | Weld-neck with Schedule 10 bore described in ASME B36.10M (excludes nozzle <sup>4</sup> and Slip-on <sup>5</sup> ) | Slip-on, Weld-neck, any bore   | Weld-neck w/ Sched. 40 bore                 | No flanges  |                             |                               |
| 18"               |                                     |   |  | Slip-on, Weld-neck, any bore   | Weld-neck w/ Sched. 40 bore                 |   |                             |                               |
| 20"               |                                     |   |  | Slip-on, Weld-neck, any bore   | Weld-neck w/ Sched. 40 bore                 |   |                             |                               |
| 24"               | Slip-on, Weld-neck, any bore        |   | Weld-neck with Schedule 10 bore described in ASME B36.10M (excludes nozzle <sup>4</sup> and Slip-on <sup>5</sup> ) | Slip-on, Weld-neck, any bore   | Weld-neck w/ Sched. 40 bore                 | No flanges  |                             |                               |
| 24"               |                                     |   |  | Slip-on, Weld-neck, any bore   | Weld-neck w/ Sched. 40 bore                 |   |                             |                               |

## Notes:

1. Inner rings are recommended for all graphite filled gaskets, required for all PTFE filled gaskets, and for NPS 24 and larger in Class 900, NPS 12 and larger in Class 1500, and NPS 4 and larger in Class 2500. (See page D-3 for full description) These inner rings may extend into the pipe bore a maximum of 0.06" (1.5 mm) under the worst combination or maximum bore, eccentric installation, and additive tolerances. Purchaser should specify inner ring material.
2. In these sizes the gasket is suitable for a weld-neck flange with a standard wall bore, if the gasket and the flange are assembled concentrically. This also applies to a nozzle. It is the user's responsibility to determine if the gasket is satisfactory for the flange of any larger bore.
3. Gaskets in these sizes are suitable for slip-on flanges only if the gaskets and flanges are assembled concentrically.

4. A nozzle is a long welded neck; the bore equals the flange NPS.
5. An NPS 24 gasket is suitable for nozzles.

## WARNING:

Properties/applications shown throughout this brochure are typical. Your specific application should not be undertaken without independent study and evaluation for suitability. For specific application recommendations consult Garlock. Failure to select the proper sealing products could result in property damage and/or serious personal injury.

Performance data published in this brochure has been developed from field testing, customer field reports and/or in-house testing.

While the utmost care has been used in compiling this brochure, we assume no responsibility for errors. Specifications subject to change without notice. This edition cancels all previous issues. Subject to change without notice.



# Styles RW, RWI Dimensions 1/4" to 24" Flanges

## ASME B16.20 Gaskets for ASME B16.5 Flanges

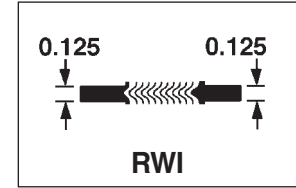
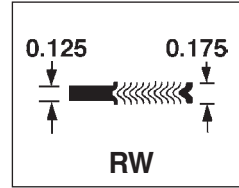
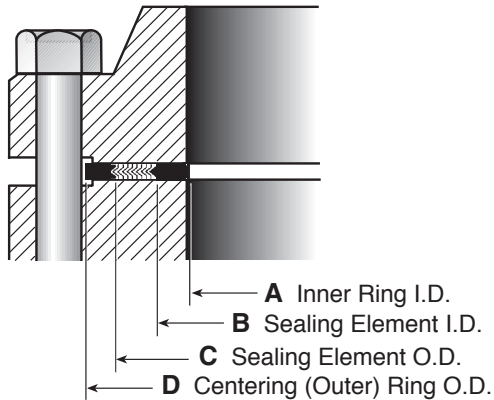

### Class 150

| Size<br>NPS | Inner Ring             | Sealing Element        |                         | Outer Ring              |
|-------------|------------------------|------------------------|-------------------------|-------------------------|
|             | Inside (A)<br>Diameter | Inside (B)<br>Diameter | Outside (C)<br>Diameter | Outside (D)<br>Diameter |
| 1/4*        | —                      | 0.50                   | 0.88                    | 1.75                    |
| 1/2         | 0.56                   | 0.75                   | 1.25                    | 1.88                    |
| 3/4         | 0.81                   | 1.00                   | 1.56                    | 2.25                    |
| 1           | 1.06                   | 1.25                   | 1.88                    | 2.63                    |
| 1-1/4       | 1.50                   | 1.88                   | 2.38                    | 3.00                    |
| 1-1/2       | 1.75                   | 2.13                   | 2.75                    | 3.38                    |
| 2           | 2.19                   | 2.75                   | 3.38                    | 4.13                    |
| 2-1/2       | 2.62                   | 3.25                   | 3.88                    | 4.88                    |
| 3           | 3.19                   | 4.00                   | 4.75                    | 5.38                    |
| 3-1/2*      | —                      | 4.50                   | 5.25                    | 6.38                    |
| 4           | 4.19                   | 5.00                   | 5.88                    | 6.88                    |
| 4-1/2*      | —                      | 5.50                   | 6.50                    | 7.00                    |
| 5           | 5.19                   | 6.13                   | 7.00                    | 7.75                    |
| 6           | 6.19                   | 7.19                   | 8.25                    | 8.75                    |
| 8           | 8.50                   | 9.19                   | 10.38                   | 11.00                   |
| 10          | 10.56                  | 11.31                  | 12.50                   | 13.38                   |
| 12          | 12.50                  | 13.38                  | 14.75                   | 16.13                   |
| 14          | 13.75                  | 14.63                  | 16.00                   | 17.75                   |
| 16          | 15.75                  | 16.63                  | 18.25                   | 20.25                   |
| 18          | 17.69                  | 18.69                  | 20.75                   | 21.63                   |
| 20          | 19.69                  | 20.69                  | 22.75                   | 23.88                   |
| 24          | 23.75                  | 24.75                  | 27.00                   | 28.25                   |

### Class 300

| Size<br>NPS | Inner Ring             | Sealing Element        |                         | Outer Ring              |
|-------------|------------------------|------------------------|-------------------------|-------------------------|
|             | Inside (A)<br>Diameter | Inside (B)<br>Diameter | Outside (C)<br>Diameter | Outside (D)<br>Diameter |
| 1/4*        | —                      | 0.50                   | 0.88                    | 1.75                    |
| 1/2         | 0.56                   | 0.75                   | 1.25                    | 2.13                    |
| 3/4         | 0.81                   | 1.00                   | 1.56                    | 2.63                    |
| 1           | 1.06                   | 1.25                   | 1.88                    | 2.88                    |
| 1-1/4       | 1.50                   | 1.88                   | 2.38                    | 3.25                    |
| 1-1/2       | 1.75                   | 2.13                   | 2.75                    | 3.75                    |
| 2           | 2.19                   | 2.75                   | 3.38                    | 4.38                    |
| 2-1/2       | 2.62                   | 3.25                   | 3.88                    | 5.13                    |
| 3           | 3.19                   | 4.00                   | 4.75                    | 5.88                    |
| 3-1/2*      | —                      | 4.50                   | 5.25                    | 6.50                    |
| 4           | 4.19                   | 5.00                   | 5.88                    | 7.13                    |
| 4-1/2*      | —                      | 5.50                   | 6.50                    | 7.75                    |
| 5           | 5.19                   | 6.13                   | 7.00                    | 8.50                    |
| 6           | 6.19                   | 7.19                   | 8.25                    | 9.88                    |
| 8           | 8.50                   | 9.19                   | 10.38                   | 12.13                   |
| 10          | 10.56                  | 11.31                  | 12.50                   | 14.25                   |
| 12          | 12.50                  | 13.38                  | 14.75                   | 16.63                   |
| 14          | 13.75                  | 14.63                  | 16.00                   | 19.13                   |
| 16          | 15.75                  | 16.63                  | 18.25                   | 21.25                   |
| 18          | 17.69                  | 18.69                  | 20.75                   | 23.50                   |
| 20          | 19.69                  | 20.69                  | 22.75                   | 25.75                   |
| 24          | 23.75                  | 24.75                  | 27.00                   | 30.50                   |

\* ASME B16.20 does not include dimensions for NPS 1/4, 3-1/2 or 4-1/2, or Class 400 flanges up to NPS 3 and Class 900 flanges up to NPS 2-1/2. Dimensions in inches.

#### Notes:

1. Inner rings are recommended for all graphite filled gaskets, required for all PTFE filled gaskets, and for NPS 24 and larger in Class 900, NPS 12 and larger in Class 1500, and NPS 4 and larger in Class 2500.
2. The gasket outside diameter tolerance for NPS 1/2 through NPS 8 is  $\pm 0.03$ "; for NPS 10 through NPS 24,  $+0.06$ ",  $-0.03$ ".
3. The gasket inside diameter tolerance for NPS 1/2 through NPS 8 is  $\pm 0.016$ "; for NPS 10 through NPS 24,  $\pm 0.03$ ".
4. The centering ring outside diameter tolerance is  $\pm 0.03$ ".
5. There are no Class 400 flanges in NPS 1/2 through NPS 3 (use Class 600), Class 900 flanges in NPS 1/2 through NPS 2-1/2 (use Class 1500), or Class 2500 flanges NPS 14 and larger.

# Styles RW, RWI Dimensions 1/4" to 24" Flanges

## Class 400

| Size<br>NPS | Inner Ring             | Sealing Element        |                         | Outer Ring              |
|-------------|------------------------|------------------------|-------------------------|-------------------------|
|             | Inside (A)<br>Diameter | Inside (B)<br>Diameter | Outside (C)<br>Diameter | Outside (D)<br>Diameter |
| 1/4*        | —                      | 0.50                   | 0.88                    | 1.75                    |
| 1/2*        | —                      | 0.75                   | 1.25                    | 2.13                    |
| 3/4*        | —                      | 1.00                   | 1.56                    | 2.63                    |
| 1*          | —                      | 1.25                   | 1.88                    | 2.88                    |
| 1-1/4*      | —                      | 1.88                   | 2.38                    | 3.25                    |
| 1-1/2*      | —                      | 2.13                   | 2.75                    | 3.75                    |
| 2*          | —                      | 2.75                   | 3.38                    | 4.38                    |
| 2-1/2*      | —                      | 3.25                   | 3.88                    | 5.13                    |
| 3*          | —                      | 4.00                   | 4.75                    | 5.88                    |
| 3-1/2*      | —                      | 4.13                   | 5.25                    | 6.38                    |
| 4           | 4.04                   | 4.75                   | 5.88                    | 7.00                    |
| 4-1/2*      | —                      | 5.31                   | 6.50                    | 7.63                    |
| 5           | 5.05                   | 5.81                   | 7.00                    | 8.38                    |
| 6           | 6.10                   | 6.88                   | 8.25                    | 9.75                    |
| 8           | 8.10                   | 8.88                   | 10.38                   | 12.00                   |
| 10          | 10.05                  | 10.81                  | 12.50                   | 14.13                   |
| 12          | 12.10                  | 12.88                  | 14.75                   | 16.50                   |
| 14          | 13.50                  | 14.25                  | 16.00                   | 19.00                   |
| 16          | 15.35                  | 16.25                  | 18.25                   | 21.13                   |
| 18          | 17.25                  | 18.50                  | 20.75                   | 23.38                   |
| 20          | 19.25                  | 20.50                  | 22.75                   | 25.50                   |
| 24          | 23.25                  | 24.75                  | 27.00                   | 30.25                   |

## Class 600

| Size<br>NPS | Inner Ring             | Sealing Element        |                         | Outer Ring              |
|-------------|------------------------|------------------------|-------------------------|-------------------------|
|             | Inside (A)<br>Diameter | Inside (B)<br>Diameter | Outside (C)<br>Diameter | Outside (D)<br>Diameter |
| 1/4*        | —                      | 0.50                   | 0.88                    | 1.75                    |
| 1/2         | 0.56                   | 0.75                   | 1.25                    | 2.13                    |
| 3/4         | 0.81                   | 1.00                   | 1.56                    | 2.63                    |
| 1           | 1.06                   | 1.25                   | 1.88                    | 2.88                    |
| 1-1/4       | 1.50                   | 1.88                   | 2.38                    | 3.25                    |
| 1-1/2       | 1.75                   | 2.13                   | 2.75                    | 3.75                    |
| 2           | 2.19                   | 2.75                   | 3.38                    | 4.38                    |
| 2-1/2       | 2.62                   | 3.25                   | 3.88                    | 5.13                    |
| 3           | 3.19                   | 4.00                   | 4.75                    | 5.88                    |
| 3-1/2*      | —                      | 4.13                   | 5.25                    | 6.38                    |
| 4           | 4.04                   | 4.75                   | 5.88                    | 7.63                    |
| 4-1/2*      | —                      | 5.31                   | 6.50                    | 8.25                    |
| 5           | 5.05                   | 5.81                   | 7.00                    | 9.50                    |
| 6           | 6.10                   | 6.88                   | 8.25                    | 10.50                   |
| 8           | 8.10                   | 8.88                   | 10.38                   | 12.63                   |
| 10          | 10.05                  | 10.81                  | 12.50                   | 15.75                   |
| 12          | 12.10                  | 12.88                  | 14.75                   | 18.00                   |
| 14          | 13.50                  | 14.25                  | 16.00                   | 19.38                   |
| 16          | 15.35                  | 16.25                  | 18.25                   | 22.25                   |
| 18          | 17.25                  | 18.50                  | 20.75                   | 24.13                   |
| 20          | 19.25                  | 20.50                  | 22.75                   | 26.88                   |
| 24          | 23.25                  | 24.75                  | 27.00                   | 31.13                   |

## Class 900

| Size<br>NPS | Inner Ring             | Sealing Element        |                         | Outer Ring              |
|-------------|------------------------|------------------------|-------------------------|-------------------------|
|             | Inside (A)<br>Diameter | Inside (B)<br>Diameter | Outside (C)<br>Diameter | Outside (D)<br>Diameter |
| 1/2*        | —                      | 0.75                   | 1.25                    | 2.50                    |
| 3/4*        | —                      | 1.00                   | 1.56                    | 2.75                    |
| 1*          | —                      | 1.25                   | 1.88                    | 3.13                    |
| 1-1/4*      | —                      | 1.56                   | 2.38                    | 3.50                    |
| 1-1/2*      | —                      | 1.88                   | 2.75                    | 3.88                    |
| 2*          | —                      | 2.31                   | 3.38                    | 5.63                    |
| 2-1/2*      | —                      | 2.75                   | 3.88                    | 6.50                    |
| 3           | 3.10                   | 3.75                   | 4.75                    | 6.63                    |
| 3-1/2*      | —                      | 4.13                   | 5.25                    | 7.50                    |
| 4           | 4.04                   | 4.75                   | 5.88                    | 8.13                    |
| 4-1/2*      | —                      | 5.31                   | 6.50                    | 9.38                    |
| 5           | 5.05                   | 5.81                   | 7.00                    | 9.75                    |
| 6           | 6.10                   | 6.88                   | 8.25                    | 11.38                   |
| 8           | 7.75                   | 8.75                   | 10.13                   | 14.13                   |
| 10          | 9.69                   | 10.88                  | 12.25                   | 17.13                   |
| 12          | 11.50                  | 12.75                  | 14.50                   | 19.63                   |
| 14          | 12.63                  | 14.00                  | 15.75                   | 20.50                   |
| 16          | 14.75                  | 16.25                  | 18.00                   | 22.63                   |
| 18          | 16.75                  | 18.25                  | 20.50                   | 25.13                   |
| 20          | 19.00                  | 20.50                  | 22.50                   | 27.50                   |
| 24          | 23.25 (5)              | 24.75                  | 26.75                   | 33.00                   |

\* ASME B16.20 does not include dimensions for NPS 1/4, 3-1/2 or 4-1/2, or Class 400 flanges up to NPS 3 and Class 900 flanges up to NPS 2-1/2. Dimensions in inches.

### Notes:

1. Inner rings are recommended for all graphite filled gaskets, required for all PTFE filled gaskets, and for NPS 24 and larger in Class 900, NPS 12 and larger in Class 1500, and NPS 4 and larger in Class 2500.
2. The gasket outside diameter tolerance for NPS 1/2 through NPS 8 is  $\pm 0.03$ "; for NPS 10 through NPS 24,  $+0.06$ ",  $-0.03$ ".
3. The gasket inside diameter tolerance for NPS 1/2 through NPS 8 is  $\pm 0.016$ "; for NPS 10 through NPS 24,  $\pm 0.03$ ".
4. The centering ring outside diameter tolerance is  $\pm 0.03$ ".
5. There are no Class 400 flanges in NPS 1/2 through NPS 3 (use Class 600), Class 900 flanges in NPS 1/2 through NPS 2-1/2 (use Class 1500), or Class 2500 flanges NPS 14 and larger.

# Styles RW, RWI Dimensions 1/4" to 24" Flanges

## ASME B16.20 Gaskets for ASME B16.5 Flanges

### Class 1500

| Size<br>NPS | Inner<br>Ring          | Sealing Element        |                         | Outer<br>Ring           |
|-------------|------------------------|------------------------|-------------------------|-------------------------|
|             | Inside (A)<br>Diameter | Inside (B)<br>Diameter | Outside (C)<br>Diameter | Outside (D)<br>Diameter |
| 1/2         | 0.56                   | 0.75                   | 1.25                    | 2.50                    |
| 3/4         | 0.81                   | 1.00                   | 1.56                    | 2.75                    |
| 1           | 1.06                   | 1.25                   | 1.88                    | 3.13                    |
| 1-1/4       | 1.31 (4)               | 1.56                   | 2.38                    | 3.50                    |
| 1-1/2       | 1.63 (4)               | 1.88                   | 2.75                    | 3.88                    |
| 2           | 2.06 (4)               | 2.31                   | 3.38                    | 5.63                    |
| 2-1/2       | 2.50 (4)               | 2.75                   | 3.88                    | 6.50                    |
| 3           | 3.10                   | 3.63                   | 4.75                    | 6.88                    |
| 3-1/2*      | —                      | 4.13                   | 5.25                    | 7.38                    |
| 4           | 3.85                   | 4.63                   | 5.88                    | 8.25                    |
| 4-1/2*      | —                      | 5.31                   | 6.50                    | 9.13                    |
| 5           | 4.90                   | 5.63                   | 7.00                    | 10.00                   |
| 6           | 5.80                   | 6.75                   | 8.25                    | 11.13                   |
| 8           | 7.75                   | 8.50                   | 10.13                   | 13.88                   |
| 10          | 9.69                   | 10.50                  | 12.25                   | 17.13                   |
| 12          | 11.50 (5)              | 12.75                  | 14.50                   | 20.50                   |
| 14          | 12.63 (5)              | 14.25                  | 15.75                   | 22.75                   |
| 16          | 14.50 (5)              | 16.00                  | 18.00                   | 25.25                   |
| 18          | 16.75 (5)              | 18.25                  | 20.50                   | 27.75                   |
| 20          | 18.75 (5)              | 20.25                  | 22.50                   | 29.75                   |
| 24          | 22.75 (5)              | 24.25                  | 26.75                   | 35.50                   |

### Class 2500

| Size<br>NPS | Inner<br>Ring          | Sealing Element        |                         | Outer<br>Ring           |
|-------------|------------------------|------------------------|-------------------------|-------------------------|
|             | Inside (A)<br>Diameter | Inside (B)<br>Diameter | Outside (C)<br>Diameter | Outside (D)<br>Diameter |
| 1/2         | 0.56                   | 0.75                   | 1.25                    | 2.75                    |
| 3/4         | 0.81                   | 1.00                   | 1.56                    | 3.00                    |
| 1           | 1.06                   | 1.25                   | 1.88                    | 3.38                    |
| 1-1/4       | 1.31 (4)               | 1.56                   | 2.38                    | 4.13                    |
| 1-1/2       | 1.63 (4)               | 1.88                   | 2.75                    | 4.63                    |
| 2           | 2.06 (4)               | 2.31                   | 3.38                    | 5.75                    |
| 2-1/2       | 2.50 (4)               | 2.75                   | 3.88                    | 6.63                    |
| 3           | 3.10                   | 3.63                   | 4.75                    | 7.75                    |
| 4           | 3.85 (5)               | 4.63                   | 5.88                    | 9.25                    |
| 5           | 4.90 (5)               | 5.63                   | 7.00                    | 11.00                   |
| 6           | 5.80 (5)               | 6.75                   | 8.25                    | 12.50                   |
| 8           | 7.75 (5)               | 8.50                   | 10.13                   | 15.25                   |
| 10          | 9.69 (5)               | 10.63                  | 12.25                   | 18.75                   |
| 12          | 11.50 (5)              | 12.50                  | 14.50                   | 21.63                   |

\* ASME B16.20 does not include dimensions for NPS 1/4, 3-1/2 or 4-1/2, or Class 400 flanges up to NPS 3 and Class 900 flanges up to NPS 2-1/2.  
Dimensions in inches.

#### Notes:

1. Inner rings are recommended for all graphite filled gaskets, required for all PTFE filled gaskets, and for NPS 24 and larger in Class 900, NPS 12 and larger in Class 1500, and NPS 4 and larger in Class 2500.
2. The gasket outside diameter tolerance for NPS 1/2 through NPS 8 is  $\pm 0.03$ "; for NPS 10 through NPS 24,  $+0.06$ ",  $-0.03$ ".
3. The gasket inside diameter tolerance for NPS 1/2 through NPS 8 is  $\pm 0.016$ "; for NPS 10 through NPS 24,  $\pm 0.03$ ".
4. The centering ring outside diameter tolerance is  $\pm 0.03$ ".
5. There are no Class 400 flanges in NPS 1/2 through NPS 3 (use Class 600), Class 900 flanges in NPS 1/2 through NPS 2-1/2 (use Class 1500), or Class 2500 flanges NPS 14 and larger.

#### WARNING:

Properties/applications shown throughout this brochure are typical. Your specific application should not be undertaken without independent study and evaluation for suitability. For specific application recommendations consult Garlock. Failure to select the proper sealing products could result in property damage and/or serious personal injury.

Performance data published in this brochure has been developed from field testing, customer field reports and/or in-house testing.

While the utmost care has been used in compiling this brochure, we assume no responsibility for errors. Specifications subject to change without notice. This edition cancels all previous issues. Subject to change without notice.

# Styles RW, RWI Dimensions 22-60" Series A Flanges

## ASME B16.20 Gaskets for ASME B16.47 Series A Flanges (MSS SP-44)

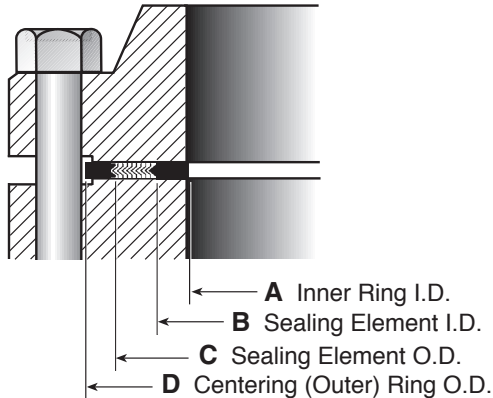

## Class 150

| Size<br>NPS | Inner Ring             | Sealing Element        |                         | Outer Ring              |
|-------------|------------------------|------------------------|-------------------------|-------------------------|
|             | Inside (A)<br>Diameter | Inside (B)<br>Diameter | Outside (C)<br>Diameter | Outside (D)<br>Diameter |
| 22*         | —                      | 22.75                  | 24.00                   | 26.00                   |
| 26          | 25.75                  | 26.50                  | 27.75                   | 30.50                   |
| 28          | 27.75                  | 28.50                  | 29.75                   | 32.75                   |
| 30          | 29.75                  | 30.50                  | 31.75                   | 34.75                   |
| 32          | 31.75                  | 32.50                  | 33.88                   | 37.00                   |
| 34          | 33.75                  | 34.50                  | 35.88                   | 39.00                   |
| 36          | 35.75                  | 36.50                  | 38.13                   | 41.25                   |
| 38          | 37.75                  | 38.50                  | 40.13                   | 43.75                   |
| 40          | 39.75                  | 40.50                  | 42.13                   | 45.75                   |
| 42          | 41.75                  | 42.50                  | 44.25                   | 48.00                   |
| 44          | 43.75                  | 44.50                  | 46.38                   | 50.25                   |
| 46          | 45.75                  | 46.50                  | 48.38                   | 52.25                   |
| 48          | 47.75                  | 48.50                  | 50.38                   | 54.50                   |
| 50          | 49.75                  | 50.50                  | 52.50                   | 56.50                   |
| 52          | 51.75                  | 52.50                  | 54.50                   | 58.75                   |
| 54          | 53.50                  | 54.50                  | 56.50                   | 61.00                   |
| 56          | 55.50                  | 56.50                  | 58.50                   | 63.25                   |
| 58          | 57.50                  | 58.50                  | 60.50                   | 65.50                   |
| 60          | 59.50                  | 60.50                  | 62.50                   | 67.50                   |

## Class 300

| Size<br>NPS | Inner Ring             | Sealing Element        |                         | Outer Ring              |
|-------------|------------------------|------------------------|-------------------------|-------------------------|
|             | Inside (A)<br>Diameter | Inside (B)<br>Diameter | Outside (C)<br>Diameter | Outside (D)<br>Diameter |
| 22*         | —                      | 22.75                  | 24.75                   | 27.75                   |
| 26          | 25.75                  | 27.00                  | 29.00                   | 32.88                   |
| 28          | 27.75                  | 29.00                  | 31.00                   | 35.38                   |
| 30          | 29.75                  | 31.25                  | 33.25                   | 37.50                   |
| 32          | 31.75                  | 33.50                  | 35.50                   | 39.63                   |
| 34          | 33.75                  | 35.50                  | 37.50                   | 41.63                   |
| 36          | 35.75                  | 37.63                  | 39.63                   | 44.00                   |
| 38          | 37.50                  | 38.50                  | 40.00                   | 41.50                   |
| 40          | 39.50                  | 40.25                  | 42.13                   | 43.88                   |
| 42          | 41.50                  | 42.25                  | 44.13                   | 45.88                   |
| 44          | 43.50                  | 44.50                  | 46.50                   | 48.00                   |
| 46          | 45.38                  | 46.38                  | 48.38                   | 50.13                   |
| 48          | 47.63                  | 48.63                  | 50.63                   | 52.13                   |
| 50          | 49.00                  | 51.00                  | 53.00                   | 54.25                   |
| 52          | 52.00                  | 53.00                  | 55.00                   | 56.25                   |
| 54          | 53.25                  | 55.25                  | 57.25                   | 58.75                   |
| 56          | 55.25                  | 57.25                  | 59.25                   | 60.75                   |
| 58          | 57.00                  | 59.50                  | 61.50                   | 62.75                   |
| 60          | 60.00                  | 61.50                  | 63.50                   | 64.75                   |

## Class 400

| Size<br>NPS | Inner Ring             | Sealing Element        |                         | Outer Ring              |
|-------------|------------------------|------------------------|-------------------------|-------------------------|
|             | Inside (A)<br>Diameter | Inside (B)<br>Diameter | Outside (C)<br>Diameter | Outside (D)<br>Diameter |
| 22*         | —                      | 22.75                  | 24.75                   | 27.63                   |
| 26          | 26.00                  | 27.00                  | 29.00                   | 32.75                   |
| 28          | 28.00                  | 29.00                  | 31.00                   | 35.13                   |
| 30          | 29.75                  | 31.25                  | 33.25                   | 37.25                   |
| 32          | 32.00                  | 33.50                  | 35.50                   | 39.50                   |
| 34          | 34.00                  | 35.50                  | 37.50                   | 41.50                   |
| 36          | 36.13                  | 37.63                  | 39.63                   | 44.00                   |
| 38          | 37.50                  | 38.25                  | 40.25                   | 42.25                   |
| 40          | 39.38                  | 40.38                  | 42.38                   | 44.38                   |
| 42          | 41.38                  | 42.38                  | 44.38                   | 46.38                   |
| 44          | 43.50                  | 44.50                  | 46.50                   | 48.50                   |
| 46          | 46.00                  | 47.00                  | 49.00                   | 50.75                   |
| 48          | 47.50                  | 49.00                  | 51.00                   | 53.00                   |
| 50          | 49.50                  | 51.00                  | 53.00                   | 55.25                   |
| 52          | 51.50                  | 53.00                  | 55.00                   | 57.25                   |
| 54          | 53.25                  | 55.25                  | 57.25                   | 59.75                   |
| 56          | 55.25                  | 57.25                  | 59.25                   | 61.75                   |
| 58          | 57.25                  | 59.25                  | 61.25                   | 63.75                   |
| 60          | 59.75                  | 61.75                  | 63.75                   | 66.25                   |

### Notes:

1. Inner rings are recommended for all graphite filled gaskets, required for all PTFE filled gaskets, and for NPS 24 and larger in Class 900, NPS 12 and larger in Class 1500, and NPS 4 and larger in Class 2500.
2. The gasket inside diameter tolerance for NPS 26 through NPS 34 is  $\pm 0.03$ "; for NPS 36 through NPS 60 is  $\pm 0.05$ ".
3. The gasket outside diameter tolerance for NPS 26 through NPS 60 is  $\pm 0.06$ ".
4. The centering ring outside diameter tolerance is  $\pm 0.03$ ".
5. There are no Class 900 flanges in NPS 50 and larger.

# Styles RW, RWI Dimensions 22-60" Series A Flanges

## ASME B16.20 Gaskets for ASME B16.47 Series A Flanges (MSS SP-44)

### Class 600

| Size<br>NPS | Inner<br>Ring          | Sealing Element        |                         | Outer<br>Ring           |
|-------------|------------------------|------------------------|-------------------------|-------------------------|
|             | Inside (A)<br>Diameter | Inside (B)<br>Diameter | Outside (C)<br>Diameter | Outside (D)<br>Diameter |
| 22*         | —                      | 22.75                  | 24.75                   | 28.88                   |
| 26          | 25.50                  | 27.00                  | 29.00                   | 34.13                   |
| 28          | 27.50                  | 29.00                  | 31.00                   | 36.00                   |
| 30          | 29.75                  | 31.25                  | 33.25                   | 38.25                   |
| 32          | 32.00                  | 33.50                  | 35.50                   | 40.25                   |
| 34          | 34.00                  | 35.50                  | 37.50                   | 42.25                   |
| 36          | 36.13                  | 37.63                  | 39.63                   | 44.50                   |
| 38          | 37.50                  | 39.00                  | 41.00                   | 43.50                   |
| 40          | 39.75                  | 41.25                  | 43.25                   | 45.50                   |
| 42          | 42.00                  | 43.50                  | 45.50                   | 48.00                   |
| 44          | 43.75                  | 45.75                  | 47.75                   | 50.00                   |
| 46          | 45.75                  | 47.75                  | 49.75                   | 52.25                   |
| 48          | 48.00                  | 50.00                  | 52.00                   | 54.75                   |
| 50          | 50.00                  | 52.00                  | 54.00                   | 57.00                   |
| 52          | 52.00                  | 54.00                  | 56.00                   | 59.00                   |
| 54          | 54.25                  | 56.25                  | 58.25                   | 61.25                   |
| 56          | 56.25                  | 58.25                  | 60.25                   | 63.50                   |
| 58          | 58.00                  | 60.50                  | 62.50                   | 65.50                   |
| 60          | 60.25                  | 62.75                  | 64.75                   | 68.25                   |

### Class 900

| Size<br>NPS | Inner<br>Ring          | Sealing Element        |                         | Outer<br>Ring           |
|-------------|------------------------|------------------------|-------------------------|-------------------------|
|             | Inside (A)<br>Diameter | Inside (B)<br>Diameter | Outside (C)<br>Diameter | Outside (D)<br>Diameter |
| 22*         | —                      | 24.25                  | 27.00                   | 33.00                   |
| 26          | 26.00                  | 27.00                  | 29.00                   | 34.75 <sup>(1)</sup>    |
| 28          | 28.00                  | 29.00                  | 31.00                   | 37.25 <sup>(1)</sup>    |
| 30          | 30.25                  | 31.25                  | 33.25                   | 39.75 <sup>(1)</sup>    |
| 32          | 32.00                  | 33.50                  | 35.50                   | 42.25 <sup>(1)</sup>    |
| 34          | 34.00                  | 35.50                  | 37.50                   | 44.75 <sup>(1)</sup>    |
| 36          | 36.25                  | 37.75                  | 39.75                   | 47.25 <sup>(1)</sup>    |
| 38          | 39.75                  | 40.75                  | 42.75                   | 47.25 <sup>(1)</sup>    |
| 40          | 41.75                  | 43.25                  | 45.25                   | 49.25 <sup>(1)</sup>    |
| 42          | 43.75                  | 45.25                  | 47.25                   | 51.25 <sup>(1)</sup>    |
| 44          | 45.50                  | 47.50                  | 49.50                   | 53.88 <sup>(1)</sup>    |
| 46          | 48.00                  | 50.00                  | 52.00                   | 56.50 <sup>(1)</sup>    |
| 48          | 50.00                  | 52.00                  | 54.00                   | 58.50 <sup>(1)</sup>    |

#### Notes:

1. Inner rings are recommended for all graphite filled gaskets, required for all PTFE filled gaskets, and for NPS 24 and larger in Class 900, NPS 12 and larger in Class 1500, and NPS 4 and larger in Class 2500.
2. The gasket inside diameter tolerance for NPS 26 through NPS 34 is  $\pm 0.03$ "; for NPS 36 through NPS 60 is  $\pm 0.05$ ".
3. The gasket outside diameter tolerance for NPS 26 through NPS 60 is  $\pm 0.06$ ".
4. The centering ring outside diameter tolerance is  $\pm 0.03$ ".
5. There are no Class 900 flanges in NPS 50 and larger.

#### WARNING:

Properties/applications shown throughout this brochure are typical. Your specific application should not be undertaken without independent study and evaluation for suitability. For specific application recommendations consult Garlock. Failure to select the proper sealing products could result in property damage and/or serious personal injury.

Performance data published in this brochure has been developed from field testing, customer field reports and/or in-house testing.

While the utmost care has been used in compiling this brochure, we assume no responsibility for errors. Specifications subject to change without notice. This edition cancels all previous issues. Subject to change without notice.



# Styles RW, RWI Dimensions 26-60" Series B Flanges

## ASME B16.20 Gaskets for ASME B16.47 Series B Flanges (API-605)

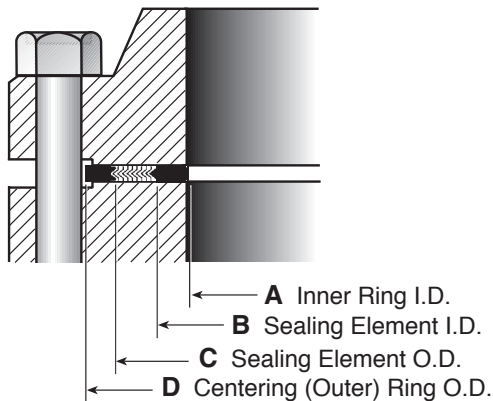

### Notes:

1. Inner rings are recommended for all graphite filled gaskets, required for all PTFE filled gaskets and for NPS 24 and larger in Class 900, NPS 12 and larger in Class 1500, and NPS 4 and larger in Class 2500.
2. The gasket inside diameter tolerance for NPS 26 through NPS 34 is  $\pm 0.03$ "; for NPS 36 through NPS 60 is  $\pm 0.05$ ".
3. The gasket outside diameter tolerance for NPS 26 through NPS 60 is  $\pm 0.06$ ".
4. The centering ring outside diameter tolerance is  $\pm 0.03$ ".
5. There are no Class 900 flanges in NPS 50 and larger.

## Class 150

| Size<br>NPS | Inner<br>Ring          | Sealing Element        |                         | Outer<br>Ring           |
|-------------|------------------------|------------------------|-------------------------|-------------------------|
|             | Inside (A)<br>Diameter | Inside (B)<br>Diameter | Outside (C)<br>Diameter | Outside (D)<br>Diameter |
| 26          | 25.75                  | 26.50                  | 27.50                   | 28.56                   |
| 28          | 27.75                  | 28.50                  | 29.50                   | 30.56                   |
| 30          | 29.75                  | 30.50                  | 31.50                   | 32.56                   |
| 32          | 31.75                  | 32.50                  | 33.50                   | 34.69                   |
| 34          | 33.75                  | 34.50                  | 35.75                   | 36.81                   |
| 36          | 35.75                  | 36.50                  | 37.75                   | 38.88                   |
| 38          | 37.75                  | 38.37                  | 39.75                   | 41.13                   |
| 40          | 39.75                  | 40.25                  | 41.88                   | 43.13                   |
| 42          | 41.75                  | 42.50                  | 43.88                   | 45.13                   |
| 44          | 43.75                  | 44.25                  | 45.88                   | 47.13                   |
| 46          | 45.75                  | 46.50                  | 48.19                   | 49.44                   |
| 48          | 47.75                  | 48.50                  | 50.00                   | 51.44                   |
| 50          | 49.75                  | 50.50                  | 52.19                   | 53.44                   |
| 52          | 51.75                  | 52.50                  | 54.19                   | 55.44                   |
| 54          | 53.75                  | 54.50                  | 56.00                   | 57.63                   |
| 56          | 56.00                  | 56.88                  | 58.18                   | 59.63                   |
| 58          | 58.19                  | 59.07                  | 60.19                   | 62.19                   |
| 60          | 60.44                  | 61.31                  | 62.44                   | 64.19                   |

## Class 75

### Large Diameter Weld Neck Flanges

| Size<br>NPS | Sealing Element        |                         | Outer<br>Ring           |
|-------------|------------------------|-------------------------|-------------------------|
|             | Inside (B)<br>Diameter | Outside (C)<br>Diameter | Outside (D)<br>Diameter |
| 26          | 26.25                  | 27.00                   | 27.88                   |
| 28          | 28.25                  | 29.13                   | 29.88                   |
| 30          | 30.25                  | 31.13                   | 31.88                   |
| 32          | 32.25                  | 33.13                   | 33.88                   |
| 34          | 34.25                  | 35.13                   | 35.88                   |
| 36          | 36.25                  | 37.25                   | 38.31                   |
| 38          | 38.25                  | 39.31                   | 40.31                   |
| 40          | 40.25                  | 41.31                   | 42.31                   |
| 42          | 42.25                  | 43.25                   | 44.31                   |
| 44          | 44.25                  | 45.50                   | 46.50                   |
| 46          | 46.25                  | 47.50                   | 48.50                   |
| 48          | 48.38                  | 49.50                   | 50.50                   |
| 50          | 50.25                  | 51.50                   | 52.50                   |
| 52          | 52.38                  | 53.63                   | 54.63                   |
| 54          | 54.38                  | 55.63                   | 56.63                   |
| 56          | 56.50                  | 57.88                   | 58.88                   |
| 58          | 58.50                  | 59.88                   | 60.88                   |
| 60          | 60.50                  | 61.75                   | 62.88                   |

## Class 300

| Size<br>NPS | Inner<br>Ring          | Sealing Element        |                         | Outer<br>Ring           |
|-------------|------------------------|------------------------|-------------------------|-------------------------|
|             | Inside (A)<br>Diameter | Inside (B)<br>Diameter | Outside (C)<br>Diameter | Outside (D)<br>Diameter |
| 26          | 25.75                  | 26.50                  | 28.00                   | 30.38                   |
| 28          | 27.75                  | 28.50                  | 30.00                   | 32.50                   |
| 30          | 29.75                  | 30.50                  | 32.00                   | 34.88                   |
| 32          | 31.75                  | 32.50                  | 34.00                   | 37.00                   |
| 34          | 33.75                  | 34.50                  | 36.00                   | 39.13                   |
| 36          | 35.75                  | 36.50                  | 38.00                   | 41.25                   |
| 38          | 38.25                  | 39.75                  | 41.25                   | 43.25                   |
| 40          | 40.25                  | 41.75                  | 43.25                   | 45.25                   |
| 42          | 42.75                  | 43.75                  | 45.25                   | 47.25                   |
| 44          | 44.25                  | 45.75                  | 47.25                   | 49.25                   |
| 46          | 46.38                  | 47.88                  | 49.38                   | 51.88                   |
| 48          | 48.50                  | 49.75                  | 51.63                   | 53.88                   |
| 50          | 49.88                  | 51.88                  | 53.38                   | 55.88                   |
| 52          | 51.88                  | 53.88                  | 55.38                   | 57.88                   |
| 54          | 53.75                  | 55.25                  | 57.25                   | 60.25                   |
| 56          | 56.25                  | 58.25                  | 60.00                   | 62.75                   |
| 58          | 58.44                  | 60.44                  | 61.94                   | 65.19                   |
| 60          | 61.31                  | 62.56                  | 64.19                   | 67.19                   |

# Styles RW, RWI Dimensions 26-60" Series B Flanges

## ASME B16.20 Gaskets for ASME B16.47 Series B Flanges (API-605)

### Class 400

| Size<br>NPS | Inner<br>Ring          | Sealing Element        |                         | Outer<br>Ring           |
|-------------|------------------------|------------------------|-------------------------|-------------------------|
|             | Inside (A)<br>Diameter | Inside (B)<br>Diameter | Outside (C)<br>Diameter | Outside (D)<br>Diameter |
| 26          | 25.75                  | 26.25                  | 27.50                   | 29.38                   |
| 28          | 27.63                  | 28.13                  | 29.50                   | 31.50                   |
| 30          | 29.63                  | 30.13                  | 31.75                   | 33.75                   |
| 32          | 31.50                  | 32.00                  | 33.88                   | 35.88                   |
| 34          | 33.50                  | 34.13                  | 35.88                   | 37.88                   |
| 36          | 35.38                  | 36.13                  | 38.00                   | 40.25                   |
| 38          | 37.50                  | 38.25                  | 40.25                   | 42.25                   |
| 40          | 39.38                  | 40.38                  | 42.38                   | 44.38                   |
| 42          | 41.38                  | 42.38                  | 44.38                   | 46.38                   |
| 44          | 43.50                  | 44.50                  | 46.50                   | 48.50                   |
| 46          | 46.00                  | 47.00                  | 49.00                   | 50.75                   |
| 48          | 47.50                  | 49.00                  | 51.00                   | 53.00                   |
| 50          | 49.50                  | 51.00                  | 53.00                   | 55.25                   |
| 52          | 51.50                  | 53.00                  | 55.00                   | 57.25                   |
| 54          | 53.25                  | 55.25                  | 57.25                   | 59.75                   |
| 56          | 55.25                  | 57.25                  | 59.25                   | 61.75                   |
| 58          | 57.25                  | 59.25                  | 61.25                   | 63.75                   |
| 60          | 59.75                  | 61.75                  | 63.75                   | 66.25                   |

### Class 600

| Size<br>NPS | Inner<br>Ring          | Sealing Element        |                         | Outer<br>Ring           |
|-------------|------------------------|------------------------|-------------------------|-------------------------|
|             | Inside (A)<br>Diameter | Inside (B)<br>Diameter | Outside (C)<br>Diameter | Outside (D)<br>Diameter |
| 26          | 25.38                  | 26.13                  | 28.13                   | 30.13                   |
| 28          | 27.25                  | 27.75                  | 29.75                   | 32.25                   |
| 30          | 29.63                  | 30.63                  | 32.63                   | 34.63                   |
| 32          | 31.25                  | 32.75                  | 34.75                   | 36.75                   |
| 34          | 33.50                  | 35.00                  | 37.00                   | 39.25                   |
| 36          | 35.50                  | 37.00                  | 39.00                   | 41.25                   |
| 38          | 37.50                  | 39.00                  | 41.00                   | 43.50                   |
| 40          | 39.75                  | 41.25                  | 43.25                   | 45.50                   |
| 42          | 42.00                  | 43.50                  | 45.50                   | 48.00                   |
| 44          | 43.75                  | 45.75                  | 47.75                   | 50.00                   |
| 46          | 45.75                  | 47.75                  | 49.75                   | 52.25                   |
| 48          | 48.00                  | 50.00                  | 52.00                   | 54.75                   |
| 50          | 50.00                  | 52.00                  | 54.00                   | 57.00                   |
| 52          | 52.00                  | 54.00                  | 56.00                   | 59.00                   |
| 54          | 54.25                  | 56.25                  | 58.25                   | 61.25                   |
| 56          | 56.25                  | 58.25                  | 60.25                   | 63.50                   |
| 58          | 58.00                  | 60.50                  | 62.50                   | 65.50                   |
| 60          | 60.25                  | 62.75                  | 64.75                   | 68.25                   |

### Class 900

| Size<br>NPS | Inner<br>Ring          | Sealing Element        |                         | Outer<br>Ring           |
|-------------|------------------------|------------------------|-------------------------|-------------------------|
|             | Inside (A)<br>Diameter | Inside (B)<br>Diameter | Outside (C)<br>Diameter | Outside (D)<br>Diameter |
| 26          | 26.25 <sup>(1)</sup>   | 27.25                  | 29.50                   | 33.00                   |
| 28          | 28.25 <sup>(1)</sup>   | 29.25                  | 31.50                   | 35.50                   |
| 30          | 30.75 <sup>(1)</sup>   | 31.75                  | 33.75                   | 37.75                   |
| 32          | 33.00 <sup>(1)</sup>   | 34.00                  | 36.00                   | 40.00                   |
| 34          | 35.25 <sup>(1)</sup>   | 36.25                  | 38.25                   | 42.25                   |
| 36          | 36.25 <sup>(1)</sup>   | 37.25                  | 39.25                   | 44.25                   |
| 38          | 39.75 <sup>(1)</sup>   | 40.75                  | 42.75                   | 47.25                   |
| 40          | 41.75 <sup>(1)</sup>   | 43.25                  | 45.25                   | 49.25                   |
| 42          | 43.75 <sup>(1)</sup>   | 45.25                  | 47.25                   | 51.25                   |
| 44          | 45.50 <sup>(1)</sup>   | 47.50                  | 49.50                   | 53.88                   |
| 46          | 48.00 <sup>(1)</sup>   | 50.00                  | 52.00                   | 56.50                   |
| 48          | 50.00 <sup>(1)</sup>   | 52.00                  | 54.00                   | 58.50                   |

#### Notes:

1. Inner rings are recommended for all graphite filled gaskets, required for all PTFE filled gaskets, and for NPS 24 and larger in Class 900, NPS 12 and larger in Class 1500, and NPS 4 and larger in Class 2500.
2. The gasket inside diameter tolerance for NPS 26 through NPS 34 is  $\pm 0.03$ "; for NPS 36 through NPS 60 is  $\pm 0.05$ ".
3. The gasket outside diameter tolerance for NPS 26 through NPS 60 is  $\pm 0.06$ ".
4. The centering ring outside diameter tolerance is  $\pm 0.03$ ".
5. There are no Class 900 flanges in NPS 50 and larger.

#### WARNING:

Properties/applications shown throughout this brochure are typical. Your specific application should not be undertaken without independent study and evaluation for suitability. For specific application recommendations consult Garlock. Failure to select the proper sealing products could result in property damage and/or serious personal injury.

Performance data published in this brochure has been developed from field testing, customer field reports and/or in-house testing.

While the utmost care has been used in compiling this brochure, we assume no responsibility for errors. Specifications subject to change without notice. This edition cancels all previous issues. Subject to change without notice.

# Style RW Dimensions Other Large Diameter Flanges, 26-96"

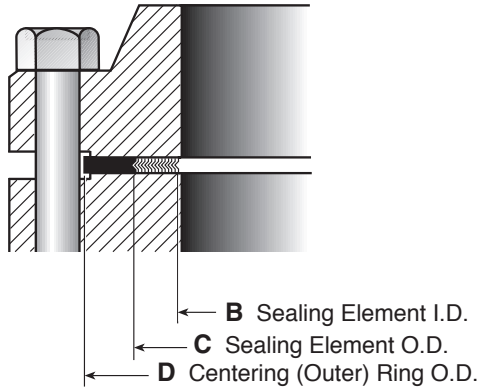

## Class 75 Slip-On and Blind

| Size<br>NPS | Sealing Element        |                         | Outer<br>Ring           |
|-------------|------------------------|-------------------------|-------------------------|
|             | Inside (B)<br>Diameter | Outside (C)<br>Diameter | Outside (D)<br>Diameter |
| 26          | 27.00                  | 28.25                   | 30.13                   |
| 28          | 29.00                  | 30.25                   | 32.13                   |
| 30          | 31.00                  | 32.25                   | 34.13                   |
| 32          | 33.13                  | 34.38                   | 36.38                   |
| 34          | 35.13                  | 36.50                   | 38.38                   |
| 36          | 37.13                  | 38.50                   | 40.38                   |
| 42          | 43.25                  | 44.75                   | 46.63                   |
| 48          | 49.25                  | 50.88                   | 52.63                   |
| 54          | 55.38                  | 57.75                   | 59.13                   |
| 60          | 61.38                  | 63.38                   | 65.13                   |
| 66          | 67.50                  | 69.50                   | 71.75                   |
| 72          | 73.50                  | 75.50                   | 77.75                   |

## Class 75 Weld Neck and Blind

| Size<br>NPS | Sealing Element        |                         | Outer<br>Ring           |
|-------------|------------------------|-------------------------|-------------------------|
|             | Inside (B)<br>Diameter | Outside (C)<br>Diameter | Outside (D)<br>Diameter |
| 26          | 26.50                  | 27.75                   | 28.75                   |
| 28          | 28.50                  | 29.75                   | 30.75                   |
| 30          | 30.50                  | 31.75                   | 32.75                   |
| 32          | 32.50                  | 33.75                   | 35.13                   |
| 34          | 34.50                  | 35.88                   | 37.13                   |
| 36          | 36.50                  | 37.88                   | 39.13                   |
| 42          | 42.50                  | 44.00                   | 45.63                   |
| 48          | 48.50                  | 50.13                   | 51.63                   |
| 54          | 54.50                  | 56.38                   | 57.88                   |
| 60          | 60.50                  | 62.50                   | 63.88                   |
| 66          | 66.50                  | 68.50                   | 70.25                   |
| 72          | 72.50                  | 74.50                   | 76.25                   |

## Class 125

| Size<br>NPS | Sealing Element        |                         | Outer<br>Ring           |
|-------------|------------------------|-------------------------|-------------------------|
|             | Inside (B)<br>Diameter | Outside (C)<br>Diameter | Outside (D)<br>Diameter |
| 22          | 22.75                  | 24.00                   | 26.00                   |
| 26          | 26.50                  | 27.75                   | 30.50                   |
| 28          | 28.50                  | 29.75                   | 32.75                   |
| 30          | 30.50                  | 31.75                   | 34.75                   |
| 32          | 32.50                  | 33.88                   | 37.00                   |
| 34          | 34.50                  | 35.88                   | 39.00                   |
| 36          | 36.50                  | 38.13                   | 41.25                   |
| 38          | 38.50                  | 40.13                   | 43.75                   |
| 40          | 40.50                  | 42.13                   | 45.75                   |
| 42          | 42.50                  | 44.25                   | 48.00                   |
| 44          | 44.50                  | 46.38                   | 50.25                   |
| 46          | 46.50                  | 48.38                   | 52.25                   |
| 48          | 48.50                  | 50.38                   | 54.50                   |
| 50          | 50.50                  | 52.50                   | 56.50                   |
| 52          | 52.50                  | 54.50                   | 58.75                   |
| 54          | 54.50                  | 56.50                   | 61.00                   |
| 60          | 60.50                  | 62.50                   | 67.50                   |
| 66          | 71.00                  | 72.75                   | 74.25                   |
| 72          | 77.50                  | 79.25                   | 80.75                   |
| 84          | 90.25                  | 92.00                   | 93.50                   |
| 96          | 103.00                 | 104.75                  | 106.25                  |

# Style RW Dimensions Other Large Diameter Flanges, 26-96"

## Class 175

| Size<br>NPS | Sealing Element        |                         | Outer<br>Ring           |
|-------------|------------------------|-------------------------|-------------------------|
|             | Inside (B)<br>Diameter | Outside (C)<br>Diameter | Outside (D)<br>Diameter |
| 26          | 26.50                  | 27.75                   | 29.13                   |
| 28          | 28.50                  | 29.75                   | 31.13                   |
| 30          | 30.50                  | 31.75                   | 33.38                   |
| 32          | 32.50                  | 33.75                   | 35.38                   |
| 34          | 34.50                  | 35.88                   | 37.50                   |
| 36          | 36.50                  | 37.88                   | 39.50                   |
| 38          | 38.50                  | 39.88                   | 41.50                   |
| 40          | 40.50                  | 42.00                   | 43.50                   |
| 42          | 42.50                  | 44.00                   | 45.88                   |
| 44          | 44.50                  | 46.00                   | 47.88                   |
| 46          | 46.50                  | 48.00                   | 49.88                   |
| 48          | 48.50                  | 50.13                   | 51.88                   |
| 50          | 50.50                  | 52.25                   | 53.88                   |
| 52          | 52.50                  | 54.38                   | 56.13                   |
| 54          | 54.50                  | 56.75                   | 58.13                   |
| 60          | 60.50                  | 62.50                   | 64.13                   |
| 66          | 67.88                  | 68.88                   | 70.13                   |
| 72          | 73.38                  | 75.13                   | 76.63                   |
| 84          | 87.00                  | 88.75                   | 90.25                   |
| 96          | 99.00                  | 100.75                  | 102.25                  |

## Class 250

| Size<br>NPS | Sealing Element        |                         | Outer<br>Ring           |
|-------------|------------------------|-------------------------|-------------------------|
|             | Inside (B)<br>Diameter | Outside (C)<br>Diameter | Outside (D)<br>Diameter |
| 26          | 26.50                  | 27.75                   | 32.75                   |
| 28          | 28.50                  | 29.75                   | 35.25                   |
| 30          | 30.50                  | 31.75                   | 37.50                   |
| 32          | 32.50                  | 33.88                   | 39.75                   |
| 34          | 34.50                  | 35.88                   | 41.75                   |
| 36          | 36.50                  | 38.13                   | 44.00                   |
| 38          | 38.50                  | 40.13                   | 46.00                   |
| 40          | 40.50                  | 42.13                   | 48.25                   |
| 42          | 42.50                  | 44.25                   | 50.75                   |
| 44          | 44.50                  | 46.38                   | 53.00                   |
| 46          | 46.50                  | 48.38                   | 55.25                   |
| 48          | 48.50                  | 50.38                   | 58.75                   |

## Class 350

| Size<br>NPS | Sealing Element        |                         | Outer<br>Ring           |
|-------------|------------------------|-------------------------|-------------------------|
|             | Inside (B)<br>Diameter | Outside (C)<br>Diameter | Outside (D)<br>Diameter |
| 26          | 26.50                  | 27.75                   | 29.63                   |
| 28          | 28.50                  | 29.75                   | 31.63                   |
| 30          | 30.50                  | 31.75                   | 33.88                   |
| 32          | 32.50                  | 33.88                   | 35.88                   |
| 34          | 34.50                  | 35.88                   | 37.88                   |
| 36          | 36.50                  | 38.13                   | 40.38                   |
| 38          | 38.50                  | 40.13                   | 42.38                   |
| 40          | 40.50                  | 42.13                   | 44.38                   |
| 42          | 42.50                  | 44.25                   | 46.63                   |
| 44          | 44.50                  | 46.38                   | 49.00                   |
| 46          | 46.50                  | 48.38                   | 51.00                   |
| 48          | 48.50                  | 50.38                   | 53.00                   |
| 52          | 52.50                  | 54.50                   | 57.38                   |
| 54          | 54.50                  | 56.50                   | 59.38                   |
| 60          | 60.50                  | 62.50                   | 65.38                   |
| 66          | 66.50                  | 68.50                   | 72.50                   |
| 72          | 72.25                  | 77.00                   | 78.50                   |
| 84          | 88.38                  | 90.13                   | 91.63                   |
| 96          | 100.75                 | 102.50                  | 104.00                  |

**WARNING:**

Properties/applications shown throughout this brochure are typical. Your specific application should not be undertaken without independent study and evaluation for suitability. For specific application recommendations consult Garlock. Failure to select the proper sealing products could result in property damage and/or serious personal injury.

Performance data published in this brochure has been developed from field testing, customer field reports and/or in-house testing.

While the utmost care has been used in compiling this brochure, we assume no responsibility for errors. Specifications subject to change without notice. This edition cancels all previous issues. Subject to change without notice.

# Gasket Factors "M" and "Y"

"M" and "Y" data are to be used for flange designs only as specified in the ASME Boiler and Pressure Vessel Code Division 1, Section VIII, Appendix 2. They are not meant to be used as gasket seating stress values in actual service. Our bolt torque tables give that information and should be used as such.

## "M" - Maintenance Factor

A factor that provides the additional preload needed in the flange fasteners to maintain the compressive load on a gasket after internal pressure is applied to a joint.







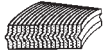
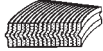

$$M = (W - A_2P) / A_1P$$

Where:  $W$  = Total Fastener force (lb. or N)  
 $A_2$  = Inside area of gasket (in.<sup>2</sup> or mm<sup>2</sup>)  
 $P$  = Test pressure (psig or N/mm<sup>2</sup>)  
 $A_1$  = Gasket area (in.<sup>2</sup> or mm<sup>2</sup>)

## "Y" - Minimum Design Seating Stress

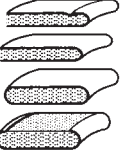
The minimum compressive stress in pounds per square inch (or bar) on the contact area of the gasket that is required to provide a seal at an internal pressure of 2 psig (0.14 bar).

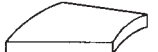
$$Y = W / A_1$$

| Gasket Design  | Gasket Material  | Gasket Factor "M"                            | Min. Design Seating Stress "Y" psi                 |
|--|--|--|--|
| Spiral wound metal, non-asbestos filled   | Stainless steel or MONEL®  | 3.00   | 10,000   |
| Garlock CONTROLLED DENSITY® flexible graphite-filled spiral wound                   | Stainless steel or MONEL®  | 3.00   | 7,500  |
| Garlock EDGE®   | Stainless steel or MONEL®  | 2.00   | 5,000  |
| Garlock GRAPHONIC®   | Stainless steel and flexible graphite<br>Liquid service:   | 2.00 (1/16")<br>9.00 (1/8")<br>2.00          | 2,000 (1/16")<br>3,000 (1/8")<br>900               |
| Corrugated metal, non-asbestos or Corrugated metal-jacketed, non-asbestos filled  | Soft aluminum<br>Soft copper or brass<br>Iron or soft steel<br>MONEL® or 4%-6% chrome<br>Stainless steel | 2.50<br>2.75<br>3.00<br>3.25<br>3.50         | 2,900<br>3,700<br>4,500<br>5,500<br>6,500          |
| Corrugated metal    | Soft aluminum<br>Soft copper or brass<br>Iron or soft steel<br>MONEL® or 4%-6% chrome<br>Stainless steel | 2.75<br>3.00<br>3.25<br>3.50<br>3.75         | 3,700<br>4,500<br>5,500<br>6,500<br>7,600          |
| Flat metal-jacketed, non-asbestos filled    | Soft aluminum<br>Soft copper or brass<br>Iron or soft steel<br>MONEL®<br>4%-6% chrome<br>Stainless steel | 3.25<br>3.50<br>3.75<br>3.50<br>3.75<br>3.75 | 5,500<br>6,500<br>7,600<br>8,000<br>9,000<br>9,000 |
| Grooved metal   | Soft aluminum<br>Soft copper or brass<br>Iron or soft steel<br>MONEL® or 4%-6% chrome<br>Stainless steel | 3.25<br>3.50<br>3.75<br>3.75<br>4.25         | 5,500<br>6,500<br>7,600<br>9,000<br>10,100         |
| Solid flat metal    | Soft aluminum<br>Soft copper or brass<br>Iron or soft steel<br>MONEL® or 4%-6% chrome<br>Stainless steel | 4.00<br>4.75<br>5.50<br>6.00<br>6.50         | 8,800<br>13,000<br>18,000<br>21,800<br>26,000      |
| Ring joint    | Iron or soft steel<br>MONEL® or 4%-6% chrome<br>Stainless steel  | 5.50<br>6.00<br>6.50                         | 18,000<br>21,800<br>26,000                         |

This table lists many commonly used gasket materials and contact facings with suggested design values of "M" and "Y" that generally have proven satisfactory in actual service when using effective gasket seating width  $B_1$  described in the formula on page D-32. The design values and other details given in this table are suggested only and are not mandatory.

MONEL® is a registered trademark of International Nickel.

# Torque Tables

These tables were developed to be used with Garlock spiral wound gaskets. They are to be used only as a general guide. They should not be considered to contain absolute values due to the large number of uncontrollable variables involved with bolted joints.

All bolt torque values are based upon the use of new nuts (ASTM A194, GR 2H) and new bolts (ASTM A193, GR B7) of proper design, acceptable quality and approved materials of construction as well as metallurgy. It is also required that two hardened steel washers be used under the head of each nut and that a thread lubricant (i.e. oil and graphite) be used on the nuts, bolts and washers.

The flanges are assumed to be in good condition and in compliance with ASME B16.5 specifications. Special attention should be given to seating surface finish and flatness.

Only torque wrenches that have been calibrated should be used. The proper bolt tightening pattern must be followed (see installation section on page D-42 for proper

bolting pattern) with the desired ultimate torque value arrived at in a minimum of three equal increments. All bolts in the flange should then be checked in consecutive bolt-to-bolt order.

The contact dimensions listed are taken from the ID and OD of the windings, which are different from the ASME ring gasket dimensions.

No provisions have been made in these tables to account for vibration effects on the bolts. These tables are based on ambient conditions, without compensation for elevated temperatures.

## **WARNING:**

Properties/applications shown throughout this brochure are typical. Your specific application should not be undertaken without independent study and evaluation for suitability. For specific application recommendations consult Garlock. Failure to select the proper sealing products could result in property damage and/or serious personal injury.

Performance data published in this brochure has been developed from field testing, customer field reports and/or in-house testing.

While the utmost care has been used in compiling this brochure, we assume no responsibility for errors. Specifications subject to change without notice. This edition cancels all previous issues. Subject to change without notice.



# Torque Tables

## 150# Raised Face Flanges

| Nom. Pipe Size (inches) | No of Bolts | Size of Bolts | FLEXSEAL®               |                           | EDGE®                   |                           | Kammprofile             |                           | GRAPHONIC®              |                           | Jacketed Gasket         |                           |
|-------------------------|-------------|---------------|-------------------------|---------------------------|-------------------------|---------------------------|-------------------------|---------------------------|-------------------------|---------------------------|-------------------------|---------------------------|
|                         |             |               | Minimum Torque (ft.lbs) | Preferred Torque (ft.lbs) | Minimum Torque (ft.lbs) | Preferred Torque (ft.lbs) | Minimum Torque (ft.lbs) | Preferred Torque (ft.lbs) | Minimum Torque (ft.lbs) | Preferred Torque (ft.lbs) | Minimum Torque (ft.lbs) | Preferred Torque (ft.lbs) |
| 0.50                    | 4           | 0.50          | 16                      | 47                        | 9                       | 52                        | 8                       | 42                        | 11                      | 37                        | 18                      | 53                        |
| 0.75                    | 4           | 0.50          | 22                      | 60                        | 12                      | 60                        | 11                      | 54                        | 16                      | 60                        | 25                      | 60                        |
| 1                       | 4           | 0.50          | 30                      | 60                        | 15                      | 60                        | 13                      | 60                        | 21                      | 60                        | 27                      | 60                        |
| 1.25                    | 4           | 0.50          | 33                      | 60                        | 16                      | 60                        | 24                      | 60                        | 33                      | 60                        | 42                      | 60                        |
| 1.5                     | 4           | 0.50          | 47                      | 60                        | 23                      | 60                        | 31                      | 60                        | 43                      | 60                        | 59                      | 60                        |
| 2                       | 4           | 0.63          | 74                      | 120                       | 36                      | 120                       | 55                      | 120                       | 87                      | 120                       | 94                      | 120                       |
| 2.5                     | 4           | 0.63          | 87                      | 120                       | 43                      | 120                       | 63                      | 120                       | 101                     | 120                       | 108                     | 120                       |
| 3                       | 4           | 0.63          | 120                     | 120                       | 63                      | 120                       | 102                     | 120                       | 120                     | 120                       | 120                     | 120                       |
| 4                       | 8           | 0.63          | 92                      | 120                       | 47                      | 120                       | 76                      | 120                       | 105                     | 120                       | 111                     | 120                       |
| 5                       | 8           | 0.75          | 124                     | 200                       | 63                      | 200                       | 106                     | 200                       | 146                     | 200                       | 189                     | 200                       |
| 6                       | 8           | 0.75          | 178                     | 200                       | 89                      | 200                       | 137                     | 200                       | 185                     | 200                       | 173                     | 200                       |
| 8                       | 8           | 0.75          | 200                     | 200                       | 128                     | 200                       | 190                     | 200                       | 250                     | 200                       | 200                     | 200                       |
| 10                      | 12          | 0.88          | 236                     | 320                       | 120                     | 320                       | 178                     | 320                       | 235                     | 320                       | 300                     | 320                       |
| 12                      | 12          | 0.88          | 320                     | 320                       | 163                     | 320                       | 178                     | 320                       | 312                     | 320                       | 320                     | 320                       |
| 14                      | 12          | 1.00          | 408                     | 490                       | 209                     | 490                       | 268                     | 490                       | 396                     | 490                       | 451                     | 490                       |
| 16                      | 16          | 1.00          | 421                     | 490                       | 210                     | 490                       | 267                     | 490                       | 377                     | 490                       | 449                     | 490                       |
| 18                      | 16          | 1.13          | 649                     | 710                       | 328                     | 710                       | 381                     | 710                       | 560                     | 710                       | 562                     | 710                       |
| 20                      | 20          | 1.13          | 572                     | 710                       | 289                     | 710                       | 335                     | 710                       | 494                     | 710                       | 562                     | 710                       |
| 24                      | 20          | 1.25          | 820                     | 1000                      | 415                     | 1000                      | 438                     | 1000                      | 704                     | 1000                      | 740                     | 1000                      |

Based on ASTM A193 B7 bolts - 60,000 psi maximum bolt stress

## 300# Raised Face Flanges

| Nom. Pipe Size (inches) | No of Bolts | Size of Bolts | FLEXSEAL®               |                           | EDGE®                   |                           | Kammprofile             |                           | GRAPHONIC®              |                           | Jacketed Gasket         |                           |
|-------------------------|-------------|---------------|-------------------------|---------------------------|-------------------------|---------------------------|-------------------------|---------------------------|-------------------------|---------------------------|-------------------------|---------------------------|
|                         |             |               | Minimum Torque (ft.lbs) | Preferred Torque (ft.lbs) | Minimum Torque (ft.lbs) | Preferred Torque (ft.lbs) | Minimum Torque (ft.lbs) | Preferred Torque (ft.lbs) | Minimum Torque (ft.lbs) | Preferred Torque (ft.lbs) | Minimum Torque (ft.lbs) | Preferred Torque (ft.lbs) |
| 0.50                    | 4           | 0.50          | 16                      | 47                        | 9                       | 52                        | 8                       | 42                        | 11                      | 37                        | 18                      | 53                        |
| 0.75                    | 4           | 0.63          | 28                      | 84                        | 15                      | 88                        | 14                      | 68                        | 20                      | 67                        | 31                      | 92                        |
| 1                       | 4           | 0.63          | 38                      | 114                       | 19                      | 115                       | 17                      | 84                        | 27                      | 89                        | 34                      | 102                       |
| 1.25                    | 4           | 0.63          | 41                      | 120                       | 20                      | 120                       | 30                      | 120                       | 41                      | 120                       | 53                      | 120                       |
| 1.5                     | 4           | 0.75          | 66                      | 198                       | 32                      | 191                       | 43                      | 200                       | 60                      | 200                       | 81                      | 200                       |
| 2                       | 8           | 0.63          | 37                      | 112                       | 18                      | 109                       | 27                      | 120                       | 43                      | 120                       | 47                      | 120                       |
| 2.5                     | 8           | 0.75          | 48                      | 145                       | 24                      | 144                       | 35                      | 177                       | 56                      | 188                       | 60                      | 180                       |
| 3                       | 8           | 0.75          | 71                      | 200                       | 35                      | 200                       | 57                      | 200                       | 83                      | 200                       | 75                      | 200                       |
| 4                       | 8           | 0.75          | 103                     | 200                       | 52                      | 200                       | 84                      | 200                       | 117                     | 200                       | 123                     | 200                       |
| 5                       | 8           | 0.75          | 124                     | 200                       | 63                      | 200                       | 106                     | 200                       | 146                     | 200                       | 189                     | 200                       |
| 6                       | 12          | 0.75          | 118                     | 200                       | 60                      | 200                       | 92                      | 200                       | 123                     | 200                       | 116                     | 200                       |
| 8                       | 12          | 0.88          | 194                     | 320                       | 98                      | 320                       | 146                     | 320                       | 192                     | 320                       | 207                     | 320                       |
| 10                      | 16          | 1.00          | 206                     | 490                       | 105                     | 490                       | 155                     | 490                       | 205                     | 490                       | 262                     | 490                       |
| 12                      | 16          | 1.13          | 309                     | 710                       | 156                     | 710                       | 171                     | 710                       | 299                     | 710                       | 341                     | 710                       |
| 14                      | 20          | 1.13          | 269                     | 710                       | 138                     | 710                       | 177                     | 710                       | 261                     | 710                       | 297                     | 710                       |
| 16                      | 20          | 1.25          | 399                     | 1000                      | 203                     | 1000                      | 259                     | 1000                      | 365                     | 1000                      | 435                     | 1000                      |
| 18                      | 24          | 1.25          | 478                     | 1000                      | 241                     | 1000                      | 280                     | 1000                      | 412                     | 1000                      | 414                     | 1000                      |
| 20                      | 24          | 1.25          | 526                     | 1000                      | 266                     | 1000                      | 308                     | 1000                      | 454                     | 1000                      | 517                     | 1000                      |
| 24                      | 24          | 1.50          | 723                     | 1600                      | 366                     | 1600                      | 386                     | 1600                      | 621                     | 1600                      | 652                     | 1600                      |

Based on ASTM A193 B7 bolts - 60,000 psi maximum bolt stress

# Torque Tables

## 400# Raised Face Flanges

| Nom. Pipe Size (inches) | No of Bolts | Size of Bolts | FLEXSEAL®               |                           | EDGE®                   |                           | Kammprofile             |                           | GRAPHONIC®              |                           | Jacketed Gasket         |                           |
|-------------------------|-------------|---------------|-------------------------|---------------------------|-------------------------|---------------------------|-------------------------|---------------------------|-------------------------|---------------------------|-------------------------|---------------------------|
|                         |             |               | Minimum Torque (ft.lbs) | Preferred Torque (ft.lbs) | Minimum Torque (ft.lbs) | Preferred Torque (ft.lbs) | Minimum Torque (ft.lbs) | Preferred Torque (ft.lbs) | Minimum Torque (ft.lbs) | Preferred Torque (ft.lbs) | Minimum Torque (ft.lbs) | Preferred Torque (ft.lbs) |
| 0.50                    | 4           | 0.50          | 16                      | 47                        | 17                      | 52                        | 8                       | 42                        | Contact Engineering     |                           | 18                      | 53                        |
| 0.75                    | 4           | 0.63          | 28                      | 84                        | 29                      | 88                        | 14                      | 68                        |                         |                           | 31                      | 92                        |
| 1                       | 4           | 0.63          | 38                      | 114                       | 38                      | 115                       | 17                      | 84                        |                         |                           | 34                      | 102                       |
| 1.25                    | 4           | 0.63          | 41                      | 120                       | 40                      | 120                       | 30                      | 120                       |                         |                           | 53                      | 120                       |
| 1.5                     | 4           | 0.75          | 66                      | 198                       | 64                      | 191                       | 43                      | 200                       |                         |                           | 81                      | 200                       |
| 2                       | 8           | 0.63          | 37                      | 112                       | 36                      | 109                       | 27                      | 120                       |                         |                           | 47                      | 120                       |
| 2.5                     | 8           | 0.75          | 48                      | 145                       | 48                      | 144                       | 35                      | 177                       |                         |                           | 60                      | 180                       |
| 3                       | 8           | 0.75          | 71                      | 200                       | 71                      | 200                       | 57                      | 200                       |                         |                           | 75                      | 200                       |
| 4                       | 8           | 0.88          | 149                     | 320                       | 120                     | 320                       | 97                      | 320                       |                         |                           | 142                     | 320                       |
| 5                       | 8           | 0.88          | 190                     | 320                       | 146                     | 320                       | 123                     | 320                       |                         |                           | 218                     | 320                       |
| 6                       | 12          | 0.88          | 173                     | 320                       | 138                     | 320                       | 106                     | 320                       |                         |                           | 133                     | 320                       |
| 8                       | 12          | 1.00          | 280                     | 490                       | 22-                     | 490                       | 170                     | 490                       |                         |                           | 241                     | 490                       |
| 10                      | 16          | 1.13          | 314                     | 710                       | 230                     | 691                       | 170                     | 710                       |                         |                           | 287                     | 710                       |
| 12                      | 16          | 1.25          | 456                     | 1000                      | 345                     | 1000                      | 188                     | 941                       |                         |                           | 376                     | 1000                      |
| 14                      | 20          | 1.25          | 373                     | 1000                      | 304                     | 911                       | 195                     | 975                       |                         |                           | 328                     | 983                       |
| 16                      | 20          | 1.38          | 532                     | 1630                      | 445                     | 1335                      | 283                     | 1360                      |                         |                           | 475                     | 1360                      |
| 18                      | 24          | 1.38          | 567                     | 1360                      | 527                     | 1360                      | 306                     | 1360                      |                         |                           | 452                     | 1357                      |
| 20                      | 24          | 1.50          | 604                     | 1600                      | 563                     | 1600                      | 326                     | 1600                      |                         |                           | 547                     | 1600                      |
| 24                      | 24          | 1.75          | 962                     | 2887                      | 975                     | 2924                      | 513                     | 2566                      |                         | 868                       | 2603                    |                           |

Based on ASTM A193 B7 bolts - 60,000 psi maximum bolt stress

## 600# Raised Face Flanges

| Nom. Pipe Size (inches) | No of Bolts | Size of Bolts | FLEXSEAL®               |                           | EDGE®                   |                           | Kammprofile             |                           | GRAPHONIC®              |                           | Jacketed Gasket         |                           |
|-------------------------|-------------|---------------|-------------------------|---------------------------|-------------------------|---------------------------|-------------------------|---------------------------|-------------------------|---------------------------|-------------------------|---------------------------|
|                         |             |               | Minimum Torque (ft.lbs) | Preferred Torque (ft.lbs) | Minimum Torque (ft.lbs) | Preferred Torque (ft.lbs) | Minimum Torque (ft.lbs) | Preferred Torque (ft.lbs) | Minimum Torque (ft.lbs) | Preferred Torque (ft.lbs) | Minimum Torque (ft.lbs) | Preferred Torque (ft.lbs) |
| 0.50                    | 4           | 0.50          | 16                      | 47                        | 17                      | 52                        | 8                       | 42                        | Contact Engineering     |                           | 18                      | 53                        |
| 0.75                    | 4           | 0.63          | 28                      | 84                        | 29                      | 88                        | 14                      | 68                        |                         |                           | 31                      | 92                        |
| 1                       | 4           | 0.63          | 38                      | 114                       | 38                      | 115                       | 17                      | 84                        |                         |                           | 34                      | 102                       |
| 1.25                    | 4           | 0.63          | 41                      | 120                       | 40                      | 120                       | 30                      | 120                       |                         |                           | 53                      | 120                       |
| 1.5                     | 4           | 0.75          | 66                      | 198                       | 64                      | 191                       | 43                      | 200                       |                         |                           | 81                      | 200                       |
| 2                       | 8           | 0.63          | 37                      | 112                       | 36                      | 109                       | 27                      | 120                       |                         |                           | 47                      | 120                       |
| 2.5                     | 8           | 0.75          | 48                      | 145                       | 48                      | 144                       | 35                      | 177                       |                         |                           | 60                      | 180                       |
| 3                       | 8           | 0.75          | 71                      | 200                       | 71                      | 200                       | 57                      | 200                       |                         |                           | 75                      | 200                       |
| 4                       | 8           | 0.88          | 149                     | 320                       | 120                     | 320                       | 97                      | 320                       |                         |                           | 142                     | 320                       |
| 5                       | 8           | 1.00          | 221                     | 490                       | 170                     | 490                       | 143                     | 490                       |                         |                           | 254                     | 490                       |
| 6                       | 12          | 1.00          | 202                     | 490                       | 160                     | 480                       | 123                     | 490                       |                         |                           | 155                     | 466                       |
| 8                       | 12          | 1.13          | 307                     | 710                       | 241                     | 710                       | 187                     | 710                       |                         |                           | 264                     | 710                       |
| 10                      | 16          | 1.25          | 346                     | 1000                      | 254                     | 763                       | 188                     | 938                       |                         |                           | 317                     | 951                       |
| 12                      | 20          | 1.25          | 365                     | 1000                      | 276                     | 829                       | 151                     | 753                       |                         |                           | 301                     | 904                       |
| 14                      | 20          | 1.38          | 408                     | 1224                      | 332                     | 996                       | 213                     | 1066                      |                         |                           | 358                     | 1075                      |
| 16                      | 20          | 1.50          | 514                     | 1543                      | 430                     | 1291                      | 274                     | 1370                      |                         |                           | 460                     | 1379                      |
| 18                      | 20          | 1.63          | 757                     | 2200                      | 704                     | 2112                      | 409                     | 2044                      |                         |                           | 604                     | 1811                      |
| 20                      | 24          | 1.63          | 695                     | 2085                      | 647                     | 1941                      | 375                     | 1875                      |                         |                           | 629                     | 1886                      |
| 24                      | 24          | 1.88          | 1103                    | 3308                      | 1117                    | 3350                      | 588                     | 2940                      |                         | 994                       | 2983                    |                           |

Based on ASTM A193 B7 bolts - 60,000 psi maximum bolt stress

# Torque Tables

## 900# Raised Face Flanges

| Nom. Pipe Size (inches) | No of Bolts | Size of Bolts | FLEXSEAL®               |                           | EDGE®                   |                           | Kammprofile             |                           | GRAPHONIC®              |                           | Jacketed Gasket         |                           |
|-------------------------|-------------|---------------|-------------------------|---------------------------|-------------------------|---------------------------|-------------------------|---------------------------|-------------------------|---------------------------|-------------------------|---------------------------|
|                         |             |               | Minimum Torque (ft.lbs) | Preferred Torque (ft.lbs) | Minimum Torque (ft.lbs) | Preferred Torque (ft.lbs) | Minimum Torque (ft.lbs) | Preferred Torque (ft.lbs) | Minimum Torque (ft.lbs) | Preferred Torque (ft.lbs) | Minimum Torque (ft.lbs) | Preferred Torque (ft.lbs) |
| 0.50                    | 4           | 0.75          | 22                      | 100                       | 24                      | 100                       | 12                      | 100                       | Contact Engineering     |                           | 24                      | 73                        |
| 0.75                    | 4           | 0.75          | 31                      | 100                       | 33                      | 100                       | 15                      | 100                       |                         |                           | 34                      | 103                       |
| 1                       | 4           | 0.88          | 49                      | 160                       | 49                      | 160                       | 22                      | 160                       |                         |                           | 44                      | 131                       |
| 1.25                    | 4           | 0.88          | 53                      | 160                       | 52                      | 160                       | 39                      | 193                       |                         |                           | 68                      | 204                       |
| 1.5                     | 4           | 1.00          | 89                      | 266                       | 85                      | 256                       | 58                      | 289                       |                         |                           | 109                     | 328                       |
| 2                       | 8           | 0.88          | 48                      | 160                       | 47                      | 160                       | 35                      | 176                       |                         |                           | 60                      | 180                       |
| 2.5                     | 8           | 1.00          | 65                      | 245                       | 65                      | 245                       | 47                      | 245                       |                         |                           | 81                      | 242                       |
| 3                       | 8           | 0.88          | 106                     | 319                       | 81                      | 244                       | 66                      | 328                       |                         |                           | 87                      | 260                       |
| 4                       | 8           | 1.13          | 191                     | 572                       | 153                     | 458                       | 124                     | 622                       |                         |                           | 182                     | 545                       |
| 5                       | 8           | 1.25          | 268                     | 804                       | 206                     | 617                       | 173                     | 865                       |                         |                           | 307                     | 921                       |
| 6                       | 12          | 1.13          | 221                     | 664                       | 176                     | 527                       | 135                     | 675                       |                         |                           | 170                     | 511                       |
| 8                       | 12          | 1.38          | 333                     | 1000                      | 303                     | 909                       | 225                     | 1127                      |                         |                           | 319                     | 956                       |
| 10                      | 16          | 1.38          | 306                     | 919                       | 278                     | 835                       | 205                     | 1026                      |                         |                           | 347                     | 1040                      |
| 12                      | 20          | 1.38          | 368                     | 1103                      | 302                     | 907                       | 165                     | 824                       |                         |                           | 329                     | 988                       |
| 14                      | 20          | 1.50          | 388                     | 1164                      | 321                     | 963                       | 206                     | 1031                      |                         |                           | 347                     | 1040                      |
| 16                      | 20          | 1.63          | 514                     | 1541                      | 495                     | 1485                      | 315                     | 1575                      |                         |                           | 529                     | 1586                      |
| 18                      | 20          | 1.88          | 991                     | 2972                      | 933                     | 2800                      | 542                     | 2710                      |                         |                           | 800                     | 2401                      |
| 20                      | 20          | 2.00          | 934                     | 2802                      | 984                     | 2952                      | 540                     | 2850                      |                         |                           | 956                     | 2867                      |
| 24                      | 20          | 2.50          | 1382                    | 4400                      | 1582                    | 4747                      | 833                     | 4400                      |                         | 1409                      | 4227                    |                           |

Based on ASTM A193 B7 bolts - 60,000 psi maximum bolt stress

## 1500# Raised Face Flanges

| Nom. Pipe Size (inches) | No of Bolts | Size of Bolts | FLEXSEAL®               |                           | EDGE®                   |                           | Kammprofile             |                           | GRAPHONIC®              |                           | Jacketed Gasket         |                           |
|-------------------------|-------------|---------------|-------------------------|---------------------------|-------------------------|---------------------------|-------------------------|---------------------------|-------------------------|---------------------------|-------------------------|---------------------------|
|                         |             |               | Minimum Torque (ft.lbs) | Preferred Torque (ft.lbs) | Minimum Torque (ft.lbs) | Preferred Torque (ft.lbs) | Minimum Torque (ft.lbs) | Preferred Torque (ft.lbs) | Minimum Torque (ft.lbs) | Preferred Torque (ft.lbs) | Minimum Torque (ft.lbs) | Preferred Torque (ft.lbs) |
| 0.50                    | 4           | 0.75          | 22                      | 100                       | 24                      | 100                       | 20                      | 100                       | Contact Engineering     |                           | 24                      | 73                        |
| 0.75                    | 4           | 0.75          | 31                      | 100                       | 33                      | 100                       | 25                      | 100                       |                         |                           | 34                      | 103                       |
| 1                       | 4           | 0.88          | 49                      | 160                       | 49                      | 160                       | 36                      | 160                       |                         |                           | 44                      | 131                       |
| 1.25                    | 4           | 0.88          | 80                      | 240                       | 52                      | 160                       | 64                      | 193                       |                         |                           | 68                      | 204                       |
| 1.5                     | 4           | 1.00          | 118                     | 353                       | 85                      | 256                       | 96                      | 289                       |                         |                           | 109                     | 328                       |
| 2                       | 8           | 0.88          | 76                      | 227                       | 47                      | 160                       | 59                      | 176                       |                         |                           | 60                      | 180                       |
| 2.5                     | 8           | 1.00          | 108                     | 325                       | 65                      | 245                       | 79                      | 245                       |                         |                           | 81                      | 242                       |
| 3                       | 8           | 1.13          | 150                     | 451                       | 104                     | 355                       | 140                     | 419                       |                         |                           | 111                     | 332                       |
| 4                       | 8           | 1.25          | 231                     | 694                       | 169                     | 506                       | 229                     | 686                       |                         |                           | 200                     | 601                       |
| 5                       | 8           | 1.50          | 323                     | 970                       | 218                     | 800                       | 305                     | 915                       |                         |                           | 325                     | 975                       |
| 6                       | 12          | 1.38          | 289                     | 867                       | 212                     | 680                       | 272                     | 815                       |                         |                           | 206                     | 617                       |
| 8                       | 12          | 1.63          | 432                     | 1297                      | 337                     | 1100                      | 418                     | 1253                      |                         |                           | 354                     | 1063                      |
| 10                      | 12          | 1.88          | 754                     | 2262                      | 547                     | 2000                      | 673                     | 2018                      |                         |                           | 682                     | 2045                      |
| 12                      | 16          | 2.00          | 647                     | 2200                      | 532                     | 2200                      | 484                     | 2200                      |                         |                           | 580                     | 1741                      |
| 14                      | 16          | 2.25          | 684                     | 3180                      | 655                     | 3180                      | 701                     | 3180                      |                         |                           | 707                     | 2121                      |
| 16                      | 16          | 2.50          | 1141                    | 4400                      | 969                     | 4400                      | 1027                    | 4400                      |                         |                           | 1035                    | 3104                      |
| 18                      | 16          | 2.75          | 1606                    | 5920                      | 1513                    | 5920                      | 1464                    | 5920                      |                         |                           | 1297                    | 3892                      |
| 20                      | 16          | 3.00          | 1921                    | 7720                      | 1810                    | 7720                      | 1748                    | 7720                      |                         |                           | 1758                    | 5273                      |
| 24                      | 16          | 3.50          | 3100                    | 13000                     | 2867                    | 13000                     | 2516                    | 13000                     |                         | 2553                      | 7658                    |                           |

Based on ASTM A193 B7 bolts - 60,000 psi maximum bolt stress

# Torque Tables

## 2500# Raised Face Flanges

| Nom. Pipe Size (inches) | No of Bolts | Size of Bolts | FLEXSEAL®               |                           | EDGE®                   |                           | Kammprofile             |                           | GRAPHONIC®              |                           | Jacketed Gasket         |                           |
|-------------------------|-------------|---------------|-------------------------|---------------------------|-------------------------|---------------------------|-------------------------|---------------------------|-------------------------|---------------------------|-------------------------|---------------------------|
|                         |             |               | Minimum Torque (ft.lbs) | Preferred Torque (ft.lbs) | Minimum Torque (ft.lbs) | Preferred Torque (ft.lbs) | Minimum Torque (ft.lbs) | Preferred Torque (ft.lbs) | Minimum Torque (ft.lbs) | Preferred Torque (ft.lbs) | Minimum Torque (ft.lbs) | Preferred Torque (ft.lbs) |
| 0.50                    | 4           | 0.75          | 22                      | 100                       | 24                      | 100                       | 20                      | 100                       | Contact Engineering     |                           | 24                      | 73                        |
| 0.75                    | 4           | 0.75          | 31                      | 100                       | 33                      | 100                       | 25                      | 100                       |                         |                           | 34                      | 103                       |
| 1                       | 4           | 0.88          | 49                      | 160                       | 49                      | 160                       | 36                      | 160                       |                         |                           | 44                      | 131                       |
| 1.25                    | 4           | 1.00          | 93                      | 279                       | 60                      | 245                       | 75                      | 245                       |                         |                           | 79                      | 237                       |
| 1.5                     | 4           | 1.13          | 129                     | 387                       | 94                      | 355                       | 106                     | 355                       |                         |                           | 120                     | 360                       |
| 2                       | 8           | 1.00          | 88                      | 264                       | 55                      | 245                       | 68                      | 245                       |                         |                           | 70                      | 210                       |
| 2.5                     | 8           | 1.13          | 119                     | 357                       | 71                      | 355                       | 87                      | 355                       |                         |                           | 89                      | 266                       |
| 3                       | 8           | 1.25          | 166                     | 500                       | 115                     | 500                       | 154                     | 500                       |                         |                           | 122                     | 367                       |
| 4                       | 8           | 1.50          | 245                     | 800                       | 178                     | 800                       | 242                     | 800                       |                         |                           | 212                     | 636                       |
| 5                       | 8           | 1.75          | 430                     | 1500                      | 289                     | 1500                      | 406                     | 1500                      |                         |                           | 432                     | 1297                      |
| 6                       | 8           | 2.00          | 611                     | 2200                      | 448                     | 2200                      | 574                     | 2200                      |                         |                           | 434                     | 1303                      |
| 8                       | 12          | 2.00          | 548                     | 2200                      | 427                     | 2200                      | 529                     | 2200                      |                         |                           | 449                     | 1347                      |
| 10                      | 12          | 2.50          | 831                     | 4400                      | 646                     | 4400                      | 794                     | 4400                      |                         |                           | 805                     | 2415                      |
| 12                      | 12          | 2.75          | 1326                    | 5920                      | 963                     | 5920                      | 875                     | 5920                      |                         |                           | 1050                    | 3150                      |

Based on ASTM A193 B7 bolts - 60,000 psi maximum bolt stress

### WARNING:

Properties/applications shown throughout this brochure are typical. Your specific application should not be undertaken without independent study and evaluation for suitability. For specific application recommendations consult Garlock. Failure to select the proper sealing products could result in property damage and/or serious personal injury.

Performance data published in this brochure has been developed from field testing, customer field reports and/or in-house testing.

While the utmost care has been used in compiling this brochure, we assume no responsibility for errors. Specifications subject to change without notice. This edition cancels all previous issues. Subject to change without notice.

# Torque to Stress Bolts

The torque required to produce a certain stress in bolting is dependent on several conditions, including:

- Diameter and number of threads on bolt
- Condition of nut bearing surfaces
- Lubrication of bolt threads and nut bearing surfaces.

The tables below reflect the results of many tests to determine the relation between torque and bolt stress. Values are based on steel bolts that have been well-lubricated with a heavy graphite and oil mixture.

A non-lubricated bolt has an efficiency of about 50% of a well-lubricated bolt. Also, different lubricants produce results that vary from 50% to 100% of the tabulated stress figures.

For Alloy Steel Stud Bolts (Load in pounds on stud bolts when torque load is applied)

| Nominal Diameter of Bolt (inches) | Number of Threads (per inch) | Diameter at Root of Thread (inches) | Area at Root of Thread (sq. inch) | Stress          |                   |                 |                   |                 |                   |
|-----------------------------------|------------------------------|-------------------------------------|-----------------------------------|-----------------|-------------------|-----------------|-------------------|-----------------|-------------------|
|                                   |                              |                                     |                                   | 30,000 psi      |                   | 45,000 psi      |                   | 60,000 psi      |                   |
|                                   |                              |                                     |                                   | Torque (ft lbs) | Compression (lbs) | Torque (ft lbs) | Compression (lbs) | Torque (ft lbs) | Compression (lbs) |
| 1/4                               | 20                           | 0.185                               | 0.027                             | 4               | 810               | 6               | 1,215             | 8               | 1,620             |
| 5/16                              | 18                           | 0.240                               | 0.045                             | 8               | 1,350             | 12              | 2,025             | 16              | 2,700             |
| 3/8                               | 16                           | 0.294                               | 0.068                             | 12              | 2,040             | 18              | 3,060             | 24              | 4,080             |
| 7/16                              | 14                           | 0.345                               | 0.093                             | 20              | 2,790             | 30              | 4,185             | 40              | 5,580             |
| 1/2                               | 13                           | 0.400                               | 0.126                             | 30              | 3,780             | 45              | 5,670             | 60              | 7,560             |
| 9/16                              | 12                           | 0.454                               | 0.162                             | 45              | 4,860             | 68              | 7,290             | 90              | 9,720             |
| 5/8                               | 11                           | 0.507                               | 0.202                             | 60              | 6,060             | 90              | 9,090             | 120             | 12,120            |
| 3/4                               | 10                           | 0.620                               | 0.302                             | 100             | 9,060             | 150             | 13,590            | 200             | 18,120            |
| 7/8                               | 9                            | 0.731                               | 0.419                             | 160             | 12,570            | 240             | 18,855            | 320             | 25,140            |
| 1                                 | 8                            | 0.838                               | 0.551                             | 245             | 16,530            | 368             | 24,795            | 490             | 33,060            |
| 1-1/8                             | 8                            | 0.963                               | 0.728                             | 355             | 21,840            | 533             | 32,760            | 710             | 43,680            |
| 1-1/4                             | 8                            | 1.088                               | 0.929                             | 500             | 27,870            | 750             | 41,805            | 1,000           | 55,740            |
| 1-3/8                             | 8                            | 1.213                               | 1.155                             | 680             | 34,650            | 1,020           | 51,975            | 1,360           | 69,300            |
| 1-1/2                             | 8                            | 1.338                               | 1.405                             | 800             | 42,150            | 1,200           | 63,225            | 1,600           | 84,300            |
| 1-5/8                             | 8                            | 1.463                               | 1.680                             | 1,100           | 50,400            | 1,650           | 75,600            | 2,200           | 100,800           |
| 1-3/4                             | 8                            | 1.588                               | 1.980                             | 1,500           | 59,400            | 2,250           | 89,100            | 3,000           | 118,800           |
| 1-7/8                             | 8                            | 1.713                               | 2.304                             | 2,000           | 69,120            | 3,000           | 103,680           | 4,000           | 138,240           |
| 2                                 | 8                            | 1.838                               | 2.652                             | 2,200           | 79,560            | 3,300           | 119,340           | 4,400           | 159,120           |
| 2-1/4                             | 8                            | 2.088                               | 3.423                             | 3,180           | 102,690           | 4,770           | 154,035           | 6,360           | 205,380           |
| 2-1/2                             | 8                            | 2.338                               | 4.292                             | 4,400           | 128,760           | 6,600           | 193,140           | 8,800           | 257,520           |
| 2-3/4                             | 8                            | 2.588                               | 5.259                             | 5,920           | 157,770           | 8,880           | 236,655           | 11,840          | 315,540           |
| 3                                 | 8                            | 2.838                               | 6.324                             | 7,720           | 189,720           | 11,580          | 264,580           | 15,440          | 379,440           |

For Machine Bolts and Cold Rolled Steel Stud Bolts (Load in pounds on stud bolts when torque load is applied)

| Nominal Diameter of Bolt (inches) | Number of Threads (per inch) | Diameter at Root of Thread (inches) | Area at Root of Thread (sq. inch) | Stress          |                   |                 |                   |                 |                   |
|-----------------------------------|------------------------------|-------------------------------------|-----------------------------------|-----------------|-------------------|-----------------|-------------------|-----------------|-------------------|
|                                   |                              |                                     |                                   | 7,500 psi       |                   | 15,000 psi      |                   | 30,000 psi      |                   |
|                                   |                              |                                     |                                   | Torque (ft lbs) | Compression (lbs) | Torque (ft lbs) | Compression (lbs) | Torque (ft lbs) | Compression (lbs) |
| 1/4                               | 20                           | 0.185                               | 0.027                             | 1               | 203               | 2               | 405               | 4               | 810               |
| 5/16                              | 18                           | 0.240                               | 0.045                             | 2               | 338               | 4               | 675               | 8               | 1,350             |
| 3/8                               | 16                           | 0.294                               | 0.068                             | 3               | 510               | 6               | 1,020             | 12              | 2,040             |
| 7/16                              | 14                           | 0.345                               | 0.093                             | 5               | 698               | 10              | 1,395             | 20              | 2,790             |
| 1/2                               | 13                           | 0.400                               | 0.126                             | 8               | 945               | 15              | 1,890             | 30              | 3,780             |
| 9/16                              | 12                           | 0.454                               | 0.162                             | 12              | 1,215             | 23              | 2,340             | 45              | 4,860             |
| 5/8                               | 11                           | 0.507                               | 0.202                             | 15              | 1,515             | 30              | 3,030             | 60              | 6,060             |
| 3/4                               | 10                           | 0.620                               | 0.302                             | 25              | 2,265             | 50              | 4,530             | 100             | 9,060             |
| 7/8                               | 9                            | 0.731                               | 0.419                             | 40              | 3,143             | 80              | 6,285             | 160             | 12,570            |
| 1                                 | 8                            | 0.838                               | 0.551                             | 62              | 4,133             | 123             | 8,265             | 245             | 16,530            |
| 1-1/8                             | 7                            | 0.939                               | 0.693                             | 98              | 5,190             | 195             | 10,380            | 390             | 20,760            |
| 1-1/4                             | 7                            | 1.064                               | 0.890                             | 137             | 6,675             | 273             | 13,350            | 545             | 26,700            |
| 1-3/8                             | 6                            | 1.158                               | 1.054                             | 183             | 7,905             | 365             | 15,810            | 730             | 31,620            |
| 1-1/2                             | 6                            | 1.283                               | 1.294                             | 219             | 9,705             | 437             | 19,410            | 875             | 38,820            |
| 1-5/8                             | 5-1/2                        | 1.389                               | 1.515                             | 300             | 11,363            | 600             | 22,725            | 1,200           | 45,450            |
| 1-3/4                             | 5                            | 1.490                               | 1.744                             | 390             | 13,080            | 775             | 26,160            | 1,550           | 52,320            |
| 1-7/8                             | 5                            | 1.615                               | 2.049                             | 525             | 15,368            | 1,050           | 30,735            | 2,100           | 61,470            |
| 2                                 | 4-1/2                        | 1.711                               | 2.300                             | 563             | 17,250            | 1,125           | 34,500            | 2,250           | 69,000            |

# Flange and Bolt Dimensions

## For Standard Flanges

| NPS<br>(inches) | 150 psi                       |                    |                              |                            | 300 psi                       |                    |                              |                            | 400 psi                       |                    |                              |                            | 600 psi                       |                    |                              |                            |
|-----------------|-------------------------------|--------------------|------------------------------|----------------------------|-------------------------------|--------------------|------------------------------|----------------------------|-------------------------------|--------------------|------------------------------|----------------------------|-------------------------------|--------------------|------------------------------|----------------------------|
|                 | Dia. of<br>Flange<br>(inches) | No.<br>of<br>Bolts | Dia. of<br>Bolts<br>(Inches) | Bolt<br>Circle<br>(Inches) | Dia. of<br>Flange<br>(Inches) | No.<br>of<br>Bolts | Dia. of<br>Bolts<br>(Inches) | Bolt<br>Circle<br>(Inches) | Dia. of<br>Flange<br>(Inches) | No.<br>of<br>Bolts | Dia. of<br>Bolts<br>(Inches) | Bolt<br>Circle<br>(Inches) | Dia. of<br>Flange<br>(Inches) | No.<br>of<br>Bolts | Dia. of<br>Bolts<br>(Inches) | Bolt<br>Circle<br>(Inches) |
| 1/4             | 3-3/8                         | 4                  | 1/2                          | 2-1/4                      | 3-3/8                         | 4                  | 1/2                          | 2-1/4                      | 3-3/8                         | 4                  | 1/2                          | 2-1/4                      | 3-3/8                         | 4                  | 1/2                          | 2-1/4                      |
| 1/2             | 3-1/2                         | 4                  | 1/2                          | 2-3/8                      | 3-3/4                         | 4                  | 1/2                          | 2-5/8                      | 3-3/4                         | 4                  | 1/2                          | 2-5/8                      | 3-3/4                         | 4                  | 1/2                          | 2-5/8                      |
| 3/4             | 3-7/8                         | 4                  | 1/2                          | 2-3/4                      | 4-5/8                         | 4                  | 5/8                          | 3-1/4                      | 4-5/8                         | 4                  | 5/8                          | 3-1/4                      | 4-5/8                         | 4                  | 5/8                          | 3-1/4                      |
| 1               | 4-1/4                         | 4                  | 1/2                          | 3-1/8                      | 4-7/8                         | 4                  | 5/8                          | 3-1/2                      | 4-7/8                         | 4                  | 5/8                          | 3-1/2                      | 4-7/8                         | 4                  | 5/8                          | 3-1/2                      |
| 1-1/4           | 4-5/8                         | 4                  | 1/2                          | 3-1/2                      | 5-1/4                         | 4                  | 5/8                          | 3-7/8                      | 5-1/4                         | 4                  | 5/8                          | 3-7/8                      | 5-1/4                         | 4                  | 5/8                          | 3-7/8                      |
| 1-1/2           | 5                             | 4                  | 1/2                          | 3-7/8                      | 6-1/8                         | 4                  | 3/4                          | 4-1/2                      | 6-1/8                         | 4                  | 3/4                          | 4-1/2                      | 6-1/8                         | 4                  | 3/4                          | 4-1/2                      |
| 2               | 6                             | 4                  | 5/8                          | 4-3/4                      | 6-1/2                         | 8                  | 5/8                          | 5                          | 6-1/2                         | 8                  | 5/8                          | 5                          | 6-1/2                         | 8                  | 5/8                          | 5                          |
| 2-1/2           | 7                             | 4                  | 5/8                          | 5-1/2                      | 7-1/2                         | 8                  | 3/4                          | 5-7/8                      | 7-1/2                         | 8                  | 3/4                          | 5-7/8                      | 7-1/2                         | 8                  | 3/4                          | 5-7/8                      |
| 3               | 7-1/2                         | 4                  | 5/8                          | 6                          | 8-1/4                         | 8                  | 3/4                          | 6-5/8                      | 8-1/4                         | 8                  | 3/4                          | 6-5/8                      | 8-1/4                         | 8                  | 3/4                          | 6-5/8                      |
| 3-1/2           | 8-1/2                         | 8                  | 5/8                          | 7                          | 9                             | 8                  | 3/4                          | 7-1/4                      | 9                             | 8                  | 7/8                          | 7-1/4                      | 9                             | 8                  | 7/8                          | 7-1/4                      |
| 4               | 9                             | 8                  | 5/8                          | 7-1/2                      | 10                            | 8                  | 3/4                          | 7-7/8                      | 10                            | 8                  | 7/8                          | 7-7/8                      | 10-3/4                        | 8                  | 7/8                          | 8-1/2                      |
| 5               | 10                            | 8                  | 3/4                          | 8-1/2                      | 11                            | 8                  | 3/4                          | 9-1/4                      | 11                            | 8                  | 7/8                          | 9-1/4                      | 13                            | 8                  | 1                            | 10-1/2                     |
| 6               | 11                            | 8                  | 3/4                          | 9-1/2                      | 12-1/2                        | 12                 | 3/4                          | 10-5/8                     | 12-1/2                        | 12                 | 7/8                          | 10-5/8                     | 14                            | 12                 | 1                            | 11-1/2                     |
| 8               | 13-1/2                        | 8                  | 3/4                          | 11-3/4                     | 15                            | 12                 | 7/8                          | 13                         | 15                            | 12                 | 1                            | 13                         | 16-1/2                        | 12                 | 1-1/8                        | 13-3/4                     |
| 10              | 16                            | 12                 | 7/8                          | 14-1/4                     | 17-1/2                        | 16                 | 1                            | 15-1/4                     | 17-1/2                        | 16                 | 1-1/8                        | 15-1/4                     | 20                            | 16                 | 1-1/4                        | 17                         |
| 12              | 19                            | 12                 | 7/8                          | 17                         | 20-1/2                        | 16                 | 1-1/8                        | 17-3/4                     | 20-1/2                        | 16                 | 1-1/4                        | 17-3/4                     | 22                            | 20                 | 1-1/4                        | 19-1/4                     |
| 14              | 21                            | 12                 | 1                            | 18-3/4                     | 23                            | 20                 | 1-1/8                        | 20-1/4                     | 23                            | 20                 | 1-1/4                        | 20-1/4                     | 23-3/4                        | 20                 | 1-3/8                        | 20-3/4                     |
| 16              | 23-1/2                        | 16                 | 1                            | 21-1/4                     | 25-1/2                        | 20                 | 1-1/4                        | 22-1/2                     | 25-1/2                        | 20                 | 1-3/8                        | 22-1/2                     | 27                            | 20                 | 1-1/2                        | 23-3/4                     |
| 18              | 25                            | 16                 | 1-1/8                        | 22-3/4                     | 28                            | 24                 | 1-1/4                        | 24-3/4                     | 28                            | 24                 | 1-3/8                        | 24-3/4                     | 29-1/4                        | 20                 | 1-5/8                        | 25-3/4                     |
| 20              | 27-1/2                        | 20                 | 1-1/8                        | 25                         | 30-1/2                        | 24                 | 1-1/4                        | 27                         | 30-1/2                        | 24                 | 1-1/2                        | 27                         | 32                            | 24                 | 1-5/8                        | 28-1/2                     |
| 24              | 32                            | 20                 | 1-1/4                        | 29-1/2                     | 36                            | 24                 | 1-1/2                        | 32                         | 36                            | 24                 | 1-3/4                        | 32                         | 37                            | 24                 | 1-7/8                        | 33                         |

| NPS<br>(inches) | 900 psi                       |                    |                              |                            | 1500 psi                      |                    |                              |                            | 2500 psi                      |                    |                              |                            |
|-----------------|-------------------------------|--------------------|------------------------------|----------------------------|-------------------------------|--------------------|------------------------------|----------------------------|-------------------------------|--------------------|------------------------------|----------------------------|
|                 | Dia. of<br>Flange<br>(inches) | No.<br>of<br>Bolts | Dia. of<br>Bolts<br>(Inches) | Bolt<br>Circle<br>(Inches) | Dia. of<br>Flange<br>(Inches) | No.<br>of<br>Bolts | Dia. of<br>Bolts<br>(Inches) | Bolt<br>Circle<br>(Inches) | Dia. of<br>Flange<br>(Inches) | No.<br>of<br>Bolts | Dia. of<br>Bolts<br>(Inches) | Bolt<br>Circle<br>(Inches) |
| 1/2             | 4-3/4                         | 4                  | 3/4                          | 3-1/4                      | 4-3/4                         | 4                  | 3/4                          | 3-1/4                      | 5-1/4                         | 4                  | 3/4                          | 3-1/2                      |
| 3/4             | 5-1/8                         | 4                  | 3/4                          | 3-1/2                      | 5-1/8                         | 4                  | 3/4                          | 3-1/2                      | 5-1/2                         | 4                  | 3/4                          | 3-3/4                      |
| 1               | 5-7/8                         | 4                  | 7/8                          | 4                          | 5-7/8                         | 4                  | 7/8                          | 4                          | 6-1/4                         | 4                  | 7/8                          | 4-1/4                      |
| 1-1/4           | 6-1/4                         | 4                  | 7/8                          | 4-3/8                      | 6-1/4                         | 4                  | 7/8                          | 4-3/8                      | 7-1/4                         | 4                  | 1                            | 5-1/8                      |
| 1-1/2           | 7                             | 4                  | 1                            | 4-7/8                      | 7                             | 4                  | 1                            | 4-7/8                      | 8                             | 4                  | 1-1/8                        | 5-3/4                      |
| 2               | 8-1/2                         | 8                  | 7/8                          | 6-1/2                      | 8-1/2                         | 8                  | 7/8                          | 6-1/2                      | 9-1/4                         | 8                  | 1                            | 6-3/4                      |
| 2-1/2           | 9-5/8                         | 8                  | 1                            | 7-1/2                      | 9-5/8                         | 8                  | 1                            | 7-1/2                      | 10-1/2                        | 8                  | 1-1/8                        | 7-3/4                      |
| 3               | 9-1/2                         | 8                  | 7/8                          | 7-1/2                      | 10-1/2                        | 8                  | 1-1/8                        | 8                          | 12                            | 8                  | 1-1/4                        | 9                          |
| 4               | 11-1/2                        | 8                  | 1-1/8                        | 9-1/4                      | 12-1/4                        | 8                  | 1-1/4                        | 9-1/2                      | 14                            | 8                  | 1-1/2                        | 10-3/4                     |
| 5               | 13-3/4                        | 8                  | 1-1/4                        | 11                         | 14-3/4                        | 8                  | 1-1/2                        | 11-1/2                     | 16-1/2                        | 8                  | 1-3/4                        | 12-3/4                     |
| 6               | 15                            | 12                 | 1-1/8                        | 12-1/2                     | 15-1/2                        | 12                 | 1-3/8                        | 12-1/2                     | 19                            | 8                  | 2                            | 14-1/2                     |
| 8               | 18-1/2                        | 12                 | 1-3/8                        | 15-1/2                     | 19                            | 12                 | 1-5/8                        | 15-1/2                     | 21-3/4                        | 12                 | 2                            | 17-1/4                     |
| 10              | 21-1/2                        | 16                 | 1-3/8                        | 18-1/2                     | 23                            | 12                 | 1-7/8                        | 19                         | 26-1/2                        | 12                 | 2-1/2                        | 21-1/4                     |
| 12              | 24                            | 20                 | 1-3/8                        | 21                         | 26-1/2                        | 16                 | 2                            | 22-1/2                     | 30                            | 12                 | 2-3/4                        | 24-3/8                     |
| 14              | 25-1/4                        | 20                 | 1-1/2                        | 22                         | 29-1/2                        | 16                 | 2-1/4                        | 25                         |                               |                    |                              |                            |
| 16              | 27-3/4                        | 20                 | 1-5/8                        | 24-1/2                     | 32-1/2                        | 16                 | 2-1/2                        | 27-3/4                     |                               |                    |                              |                            |
| 18              | 31                            | 20                 | 1-7/8                        | 27                         | 36                            | 16                 | 2-3/4                        | 30-1/2                     |                               |                    |                              |                            |
| 20              | 33-3/4                        | 20                 | 2                            | 29-1/2                     | 38-3/4                        | 16                 | 3                            | 32-3/4                     |                               |                    |                              |                            |
| 24              | 41                            | 20                 | 2-1/2                        | 35-1/2                     | 46                            | 16                 | 3-1/2                        | 39                         |                               |                    |                              |                            |

**WARNING:**

Properties/applications shown throughout this brochure are typical. Your specific application should not be undertaken without independent study and evaluation for suitability. For specific application recommendations consult Garlock. Failure to select the proper sealing products could result in property damage and/or serious personal injury.

Performance data published in this brochure has been developed from field testing, customer field reports and/or in-house testing.

While the utmost care has been used in compiling this brochure, we assume no responsibility for errors. Specifications subject to change without notice. This edition cancels all previous issues. Subject to change without notice.



# Gasket Installation

In a flanged connection, all components must be correct to achieve a seal. The most common cause of leaky gasketed joints is improper installation procedures.

## Bolting Procedures

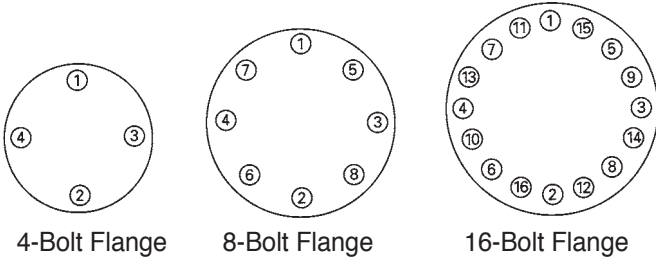

- Place the gasket on the flange surface to be sealed.
- Bring the opposing flange into contact with the gasket.
- Bolts must be new or in as-new condition. Clean the threads and lubricate them with a quality lubricant, such as an oil and graphite mixture.
- Place the bolts into the bolt holes.
- Finger-tighten the nuts.
- Follow the bolting sequence in the diagrams above.
- During the initial tightening sequence, do not tighten any bolts more than 30% of the recommended bolt stress. Doing so will cause cocking of the flange and the gasket will be crushed.
- Upon reaching the recommended torque requirements, do a circular bolt-to-bolt torque check to make certain that the bolts have been stressed evenly.
- Due to creep and stress relaxation, it is essential to prestress the bolts to ensure adequate stress load during operation.

## Prestressing Bolts for Thermal Expansion

Bolts should be prestressed to compensate for thermal expansion as well as for relaxation, creep, hydrostatic end pressure and residual gasket loads.

A difference in the coefficient of thermal expansion between the materials of the flange and the bolts may change loads. In cases of serious thermal expansion, it may be necessary to apply a minimum of stress to the bolts and allow the pipe expansion to complete the compression of the gasket.

A gasket with a centering guide ring should be compressed to the guide ring. A gasket without a centering guide ring must be installed with precautions taken to prevent thermal expansion from crushing the gasket beyond its elastic limit.

### WARNING:

Properties/applications shown throughout this brochure are typical. Your specific application should not be undertaken without independent study and evaluation for suitability. For specific application recommendations consult Garlock. Failure to select the proper sealing products could result in property damage and/or serious personal injury.

Performance data published in this brochure has been developed from field testing, customer field reports and/or in-house testing.

While the utmost care has been used in compiling this brochure, we assume no responsibility for errors. Specifications subject to change without notice. This edition cancels all previous issues. Subject to change without notice.

# Troubleshooting Leaking Joints

One of the best methods for determining the cause of joint leakage is the careful examination of the gasket where the leakage occurred.

| Observation  | Possible Remedies   |
|--|---|
| Gasket badly corroded  | <ul style="list-style-type: none"> <li>• Select replacement material with improved corrosion resistance.</li> </ul>   |
| Gasket extruded excessively  | <ul style="list-style-type: none"> <li>• Select replacement material with better cold flow properties.</li> <li>• Select replacement material with better load capacity—i.e., more dense.</li> </ul>  |
| Gasket grossly crushed   | <ul style="list-style-type: none"> <li>• Select replacement material with better load carrying capacity.</li> <li>• Provide means to prevent crushing the gasket by use of a stop ring or redesign of flanges.</li> </ul>   |
| Gasket mechanically damaged due to overhang of raised face or flange bore.             | <ul style="list-style-type: none"> <li>• Review gasket dimensions to insure gaskets are proper size.</li> <li>• Make certain gaskets are properly centered in joint.</li> </ul>   |
| No apparent gasket compression achieved  | <ul style="list-style-type: none"> <li>• Select softer gasket material.</li> <li>• Select thicker gasket material.</li> <li>• Reduce gasket area to allow higher unit seating load.</li> </ul>  |
| Gasket substantially thinner on OD than ID due to excessive flange rotation or bending | <ul style="list-style-type: none"> <li>• Alter gasket dimensions to move gasket reaction closer to bolts to minimize bending movement.</li> <li>• Provide stiffness to flange by means of back-up rings.</li> <li>• Select softer gasket material to lower required seating stresses.</li> <li>• Reduce gasket area to lower seating stresses.</li> </ul> |
| Gasket unevenly compressed around circumference  | <ul style="list-style-type: none"> <li>• Make certain proper sequential bolt-up procedures are followed.</li> <li>• Ensure flanges are properly aligned</li> </ul>  |
| Gasket thickness varies periodically around circumference                              | <ul style="list-style-type: none"> <li>• Provide reinforcing rings for flanges to better distribute bolt load.</li> <li>• Select gasket material with lower seating stress.</li> <li>• Provide additional bolts if possible to obtain better load distribution.</li> <li>• If flanges are warped, remachine or use softer gasket material.</li> </ul>     |

# Ordering Guide

## RW, RWI Spiral Wound

When ordering, specify:

- Nominal pipe size or gasket dimensions, and pressure class
- Winding and filler materials
- Centering and/or inner compression ring material

## SW Spiral Wound

When ordering, specify:

- OD and ID dimensions (and tolerance, if other than standard—see page D-19)
- Thickness of gasket
- Winding and filler material
- Inner ring material, if required (Style SWI)
- Pressure rating

## HH, MC and MCR Manhole

When ordering, specify:

- Make and model of boiler and/or equipment if available (See chart page D-10)
- Gasket style and configuration
- Dimensions of gasket (thickness, flange seating width, and shape)
- Maximum operating pressure and temperature
- Type of metal and filler materials

## Custom Gaskets

A spiral wound gasket can be made to almost any dimension required. Possible designs include multiple windings and rings, with combinations of different fillers or special winding materials and ring shapes. Describe your application or send us a drawing and we'll help you design the appropriate winding.

### WARNING:

Properties/applications shown throughout this brochure are typical. Your specific application should not be undertaken without independent study and evaluation for suitability. For specific application recommendations consult Garlock. Failure to select the proper sealing products could result in property damage and/or serious personal injury.

Performance data published in this brochure has been developed from field testing, customer field reports and/or in-house testing.

While the utmost care has been used in compiling this brochure, we assume no responsibility for errors. Specifications subject to change without notice. This edition cancels all previous issues. Subject to change without notice.

## Heat Exchanger

The size restrictions for heat exchanger gaskets depend only on the available sizes of the materials. Heat exchanger gaskets are commonly made in diameters up to 120", with rib widths up to 1-1/4" and thicknesses up to 1/4".

When ordering, specify:

- Style number
- Shape (Give configuration code, page D-13)
- Thickness
- Material (metal or metal and filler)

Plus specify (according to diagram below):

1. Outside diameter
2. Inside diameter
3. Rib width
4. Radii on ribs, at rib intersect points and around bolt holes
5. Bolt circle diameter
6. Distance from center line of gasket to center line of ribs
7. Size and number of bolt holes

**Note:** In addition to the above information, drawings of your application are always helpful in proper dimensioning of gaskets.

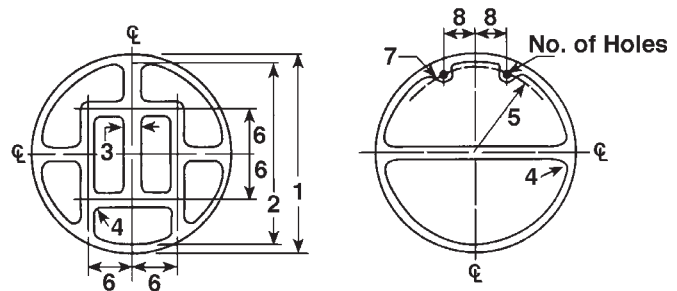

# Application Data Form

Date \_\_\_\_\_

From \_\_\_\_\_

For: Garlock Metallic Gasketing Engineering

Title \_\_\_\_\_

Fax 1-281-458-0502

Company \_\_\_\_\_

Page: 1 of \_\_\_\_\_

Address \_\_\_\_\_

Drawing attached  Yes  No

Fax No. \_\_\_\_\_

Phone No. \_\_\_\_\_

E-mail Address \_\_\_\_\_

## Application

Pipe Flange

Pumps – centrifugal / horizontal split case

Heat Exchanger

Flue Duct

Manway

Valve Bonnet

Compressor

Other \_\_\_\_\_

## Service Conditions

Maximum Temperature \_\_\_\_\_ °F/°C

Continuous Operating Temperature \_\_\_\_\_ °F/°C

Internal Pressure \_\_\_\_\_ psig / bar

PSIG / bar  Continuous  Intermittent

Thermal Cycling \_\_\_\_\_ / 24 hours

Vibration  Yes  No

Other (specify) \_\_\_\_\_

## Bolts

Grade \_\_\_\_\_

Diameter \_\_\_\_\_

Length \_\_\_\_\_

Number \_\_\_\_\_

## Chemical Compatibility

Media \_\_\_\_\_

pH \_\_\_\_\_

Concentration \_\_\_\_\_

Liquid or Gas \_\_\_\_\_

## Flange

### Standard

Material \_\_\_\_\_

Size \_\_\_\_\_ Rating \_\_\_\_\_

Surface Finish \_\_\_\_\_ RMS

Phonographic  Concentric

Face (raised, flat, tongue & groove, etc.) \_\_\_\_\_

### Non-Standard

Material \_\_\_\_\_

I.D. / O.D. \_\_\_\_\_

Flange Thickness \_\_\_\_\_

Bolt Circle Diameter \_\_\_\_\_

Surface Finish \_\_\_\_\_ RMS

Phonographic  Concentric

Face (raised, flat, tongue & groove, etc.) \_\_\_\_\_

Comments: \_\_\_\_\_

\_\_\_\_\_

\_\_\_\_\_

# Common Abbreviations

SI - International Metric Standard  
 Pa - Pascal  
 psi - pounds per square inch  
 psig - pounds per square inch gage  
 oz - ounce  
 g - gram  
 lbf - pound force  
 kgf - kilogram force

N - Newton  
 in - inch  
 ft - foot  
 yd - yard  
 m - meter  
 gal - gallon  
 l - liter

# Prefixes

M (mega) = 1,000,000 =  $10^6$   
 k (kilo) = 1,000 =  $10^3$   
 c (centi) = 0.01 =  $10^{-2}$   
 m (milli) = 0.001 =  $10^{-3}$   
 u (micro) = 0.000001 =  $10^{-6}$

# Metric Conversions

| To Convert from:   | To SI Units:      | Multiply by: |
|--------------------|-------------------|--------------|
| <b>Length</b>      |                   |              |
| mil                | mm                | 0.0254       |
| in                 | mm                | 25.4         |
| in                 | cm                | 2.54         |
| ft                 | m                 | 0.3048       |
| yd                 | m                 | 0.9144       |
| <b>Weight</b>      |                   |              |
| oz                 | g                 | 28.35        |
| oz                 | kg                | 0.0283       |
| lb                 | g                 | 453.6        |
| lb                 | kg                | 0.4536       |
| lb                 | N                 | 4.4482       |
| <b>Force</b>       |                   |              |
| lbf                | N                 | 4.448        |
| kgf                | N                 | 9.8066       |
| <b>Area</b>        |                   |              |
| in <sup>2</sup>    | cm <sup>2</sup>   | 6.4516       |
| ft <sup>2</sup>    | m <sup>2</sup>    | 0.0929       |
| <b>Pressure</b>    |                   |              |
| bar                | psi               | 14.5         |
| psi                | Pa                | 6895         |
| psi                | kPa               | 6.89         |
| psi                | bar               | 0.069        |
| psi                | MPa               | 0.0069       |
| N/m <sup>2</sup>   | Pa                | 1.00         |
| N/mm <sup>2</sup>  | MPa               | 1.00         |
| <b>Torque</b>      |                   |              |
| in-lb              | Nm                | 0.113        |
| ft-lb              | Nm                | 1.3558       |
| <b>Density</b>     |                   |              |
| oz/in <sup>3</sup> | g/cm <sup>3</sup> | 1.73         |
| g/cm <sup>3</sup>  | kg/m <sup>3</sup> | 1000         |
| lb/ft <sup>3</sup> | kg/m <sup>3</sup> | 16.02        |
| lb/ft <sup>3</sup> | g/cm <sup>3</sup> | 0.01602      |
| <b>Adhesion</b>    |                   |              |
| lb/in              | kN/m              | 0.1751       |
| <b>Volume</b>      |                   |              |
| gal                | l                 | 3.7854       |
| gal                | m <sup>3</sup>    | 0.0038       |

# More than just great products...

**Beyond offering you the widest available range of products for packing and sealing, Garlock enhances the value of its products with technical services and comprehensive training programs:**

- ISO 9001:2000 registration for Industrial Gasketing, Industrial Packing, KLOZURE® Oil Seals, Bearing Protectors, and Mechanical Seals, Expansion Joints, Hydraulic Components, and Industrial Rubber Products.
- A global network of stocking Authorized Garlock Distributors.
- Factory sales representatives and applications engineers available for problem solving when and where it is needed.
- Toll-free 800 telephone and fax numbers for immediate product information.
- In-plant surveys of equipment and processes, providing the customer with recommendations to identify and eliminate sealing and packing problems before they start.
- The most sophisticated and most comprehensive test facilities available.
- Technical field seminars on all Garlock products.
- Factory-sponsored product training programs, including hands-on seminars, to ensure that Garlock representatives and their distributor personnel are the best in the industry.
- Technical Bulletins to keep you up-to-date on product enhancements and changes.

**Customers who specify Garlock fluid sealing products get, at no extra cost, the high quality support needed to run a profitable operation.**

## AUTHORIZED REPRESENTATIVE

**Garlock**  
SEALING TECHNOLOGIES®

an EnPro Industries company

**Garlock Sealing Technologies**  
1666 Division Street  
Palmyra, New York 14522 USA  
+1.315.597.4811  
Toll Free 1.800.448.6688  
Toll Free Fax: 1.800.543.0598  
+1.315.597.3039

**www.garlock.com**



### **WARNING:**

Properties/applications shown throughout this brochure are typical. Your specific application should not be undertaken without independent study and evaluation for suitability. For specific application recommendations consult Garlock. Failure to select the proper sealing products could result in property damage and/or serious personal injury.

Performance data published in this brochure has been developed from field testing, customer field reports and/or in-house testing.

While the utmost care has been used in compiling this brochure, we assume no responsibility for errors. Specifications subject to change without notice. This edition cancels all previous issues. Subject to change without notice.

GARLOCK is a registered trademark for packings, seals, gaskets, and other products of Garlock.

© Garlock Inc 2010. All rights reserved worldwide.

Other Garlock facilities are located in:

|                              |                          |                      |
|------------------------------|--------------------------|----------------------|
| <b>Columbia, SC, USA</b>     | Phone +1.803.783.1880    | Fax +1.803.783.4279  |
| <b>Houston, TX, USA</b>      | Phone +1.281.840.4800    | Fax +1.281.840.4756  |
| <b>Sydney, Australia</b>     | Phone +61.2.9793.2511    | Fax +61.2.9793.2544  |
| <b>São Paulo, Brazil</b>     | Phone +55.11.4352.6161   | Fax +55.11.4352.8181 |
| <b>Sherbrooke, Canada</b>    | Phone +1.819.563.8080    | Fax +1.819.563.5620  |
| <b>W. Yorkshire, England</b> | Phone +44.1422.313600    | Fax +44.1422.313601  |
| <b>Saint-Étienne, France</b> | Phone +33.4.7743.5100    | Fax +33.4.7743.5151  |
| <b>Neuss, Germany</b>        | Phone +49.2131.3490      | Fax +49.2131.349.222 |
| <b>Mexico City, Mexico</b>   | Phone +52.55.50.78.46.00 | Fax +52.555.368.0418 |
| <b>Singapore</b>             | Phone +65.6285.9322      | Fax +65.6284.5843    |
| <b>Shanghai, China</b>       | Phone +86.021.62789702   | Fax +86.021.62787826 |
| <b>Dubai, UAE</b>            | Phone +971.4.8833652     | Fax +971.4.8833682   |
| <b>Pune, India</b>           | Phone +91.20.3061.6608   | Fax +91.20.3061.6699 |