

Compression Packing Technical Manual



Garlock
SEALING TECHNOLOGIES®

an EnPro Industries company

Garlock Compression Packing

The Garlock Compression Packing facility is committed to supplying the highest quality engineered products to industry throughout the world. Garlock packing is designed to give the user the greatest return on initial investment in terms of leakage control, service life, and dependable, cost-effective product.

The facility also houses the Garlock Textile Division, where we continue to research and develop new fiber blends to bring customers a wide array of packings with optimum performance characteristics.



Style 98

Contents

Packing Products

Graphite Packings	
Style G-200	A-2
Style 1300-E	A-2
Style 1333-G	A-2
Expanded PTFE and Graphite	
Style 5100 GFO® Packing	A-3
Packmaster 6	A-3
Valve Packings for Fugitive Emissions Service	
EVSP	A-4
QUICKSET®	A-5
Style 1303-FEP	A-5
Valve Packing Accessories	
High Purity Carbon Bushings	A-6
Live Loading Hardware	A-6
Nuclear Applications	
Style G-700	A-7
Seals for Rotating Service	
HYDRA-JUST™	A-8
8093 DSA	A-9
Carbon Packings	
Style 98	A-10
Style 5000	A-10
CARBAE™ 105	A-11
CARBAE™ 108	A-11
Soot Blower Sets	
TORNADO PACK™ F1	A-11
TORNADO PACK™ F3	A-11
TORNADO PACK™ F5	A-11
GRAPH-LOCK® Sets	A-11
General Device Packings	
SYNTHEPAK® Packings	A-12
Style 1965	A-12
PTFE Packings	
Style 5888	A-13

Style 5889	A-13
Style 5904	A-13
Flush Water Products	
Style 1004 Lantern Ring Coil	A-14
FLUSH-GARD™ Seal	A-14
Crown Bush	A-14
Abrasion Resistant Aramid Fiber Packings	
Packmaster 5	A-15
Style 5200	A-15

Engineering Guidelines

Style Selection	
Style Index	A-16
Packing Materials	A-20
Construction	A-22
Material Selection	A-23
Effective Sealing	
Equipment Condition	A-24
Installation Instructions	A-25
Testing	A-27
Gasket Spacers	A-28
Gland Load	A-28

Appendix

pH Values	A-29
Common Oxidizers	A-29
Bolt Torque Table for Die-Formed Sets	A-30
Ordering Information	A-31
RPM /FPM Conversion Table	A-31
Application Data Sheet	A-32

CARBAE™, FLUSH-GARD™, and TORNADO PACK™ are trademarks of Garlock Inc.

GARFITE®, GRAPH-LOCK®, LATTICE BRAID®, MILL-RIGHT®, PACK-MASTER®, QUICKBUSHINGS®, QUICKSET®, and SYNTHEPAK® are registered trademarks of Garlock Inc.

Graphite Packings

Style G-200

Style G-200 offers the lowest friction for energy savings, the best sealability against abrasives for improved reliability and the best temperature and chemical resistance for longer packing life. G-200 is the ideal choice for high temperature rotary slurry service.



Specifications

Construction:	Latice braided flexible graphite lubricated with a graphite dispersion
Temperature:	-328°F (-200°C) to +850°F (+455°C) Atmosphere To +1200°F (650°C) in Steam
pH range:	0-14 (except strong oxidizers)
Pressure:	To 500 psi (34 bar) rotary
Shaft speed:	4,000 fpm (20 m/s)

Style 1300-E

Our entry level graphite packing, 1300-E handles high temperature rotary and valve service.

Specifications

Construction:	Offset square braided flexible graphite
Temperature:	-328°F (-200°C) to +850°F (+455°C) Atmosphere To +1200°F (650°C) in Steam
pH range:	0-14 (except strong oxidizers)
Pressure:	To 500 psi (34 bar) rotary
Shaft speed:	4,000 fpm (20 m/s) rotary

Style 1333-G

Garlock Style 1333-G is braided from graphite fiber reinforced flexible graphite yarns and high purity graphite filament yarns to provide high tensile strength and low friction. The excellent heat dissipating properties of 1333-G allows our customers to conserve both water and energy. Since Style 1333-G can be used in just about any application, our customers also realize a significant savings in inventory investment.



Specifications

Construction:	Offset square flexible graphite braid reinforced with a graphite dispersion
Temperature:	-328°F (-200°C) to +850°F (+455°C) Atmosphere To +1200°F (650°C) in Steam
pH range:	0-14 (except strong oxidizers)
Pressure:	To 500 psi (34 bar) rotary
Shaft speed:	To 4,800 fpm (23 m/s) rotary



Expanded PTFE and Graphite

Style 5100 GFO® Packing



Braided compression packing made from 100% GFO® fiber provides consistently high performance in a wide range of applications. Unlike other PTFE/graphite packing, only those made with GFO® fiber, with its 20+ year history of trouble-free performance, deliver an unmatched level of assurance, confidence and easy handling.

As a proud Seal of Assurance member, Garlock produces Style 5100 to the exacting standards that allow an operation to benefit from reduced maintenance and inventory costs. Plus style 5100 is non-contaminating so it will not stain the end product.

Remember, if it does not say Genuine GFO® on the packing, then it is not Genuine GFO®.

Specifications

Construction:	GFO® with Silicone lubrication
Temperature:	-200°F (-130°C) to +550°F (+288°C)
pH range:	0-14**
Pressure:	To 300 psi (20 bar) rotary/centrifugal To 2,000 psi (138 bar) in valves
Shaft speed:	To 3000 fpm

** Not recommended for Chlorine service
GFO is a registered trademark of WL Gore.

WARNING:

Properties/applications shown throughout this brochure are typical. Your specific application should not be undertaken without independent study and evaluation for suitability. For specific application recommendations consult Garlock. Failure to select the proper sealing products could result in property damage and/or serious personal injury.

Performance data published in this brochure has been developed from field testing, customer field reports and/or in-house testing.

While the utmost care has been used in compiling this brochure, we assume no responsibility for errors. Specifications subject to change without notice. This edition cancels all previous issues. Subject to change without notice.

GARLOCK is a registered trademark for packings, seals, gaskets, and other products of Garlock.

Packmaster 6

This flexible shock resistant packing has excellent chemical resistance and can stand up in a wide range of rotary applications. This universal applicability will translate into better cash flow from reduced inventory and lower training and installation costs.

Specifications

Construction:	Expanded PTFE with graphite and a silicone lubrication
Temperature:	-200°F (-130°C) to +550°F (+288°C)
pH range:	0-14**
Pressure:	To 300 psi (20 bar) rotary/centrifugal
Shaft speed:	To 3000 fpm

Valve Packings for Fugitive Emissions Service

EVSP

Garlock's Emissionless Valve Stem Packing or EVSP is the ideal solution for applications where fugitive emissions have to be less than 100 PPM. This fire safe, chemically resistant packing preserves our environment while improving process yield.



EVSP's outstanding sealing characteristics surpass the emission standards of today and will meet the standards of tomorrow. This allows customers to avoid fines and penalties and to make a positive impact on air quality.

As compared to traditional flat ring sets, the angled design and radial expansion of EVSP allows for multiple adjustments over the life of the packing. This means that EVSP will provide low emissions service for a greater length of time, helping to save money by reducing the need for expensive compliance alternatives like on line leak sealing.

The low friction design of EVSP allows for easy actuation and results in a more efficient use of instrument air plant resources, saving money and saving energy.

EVSP's superior radial expansion characteristics will seal even older, worn valves. This means that emissions compliance can be achieved throughout the plant without the capital cost of replacing valves or the maintenance expense of bringing valves back into manufacturer's specifications.

In addition to making the seal fire safe and chemically resistant, the densified graphite construction resists volume loss, meaning that a valve packed with EVSP will be in service for years to come.

Specifications

Construction:	GRAPH-LOCK® rings of high-purity diamond textured graphite tape, in cup and cone configuration; end rings made from Garlock Style 98
Temperature:	-328°F (-200°C) to +850°F (+455°C) atmosphere; to +1,200°F (+650°C) steam
pH Range:	0-14 (except strong oxidizers)
Pressure:	To 10,000 psi plus (690 bar)

* Patent #4,328,974

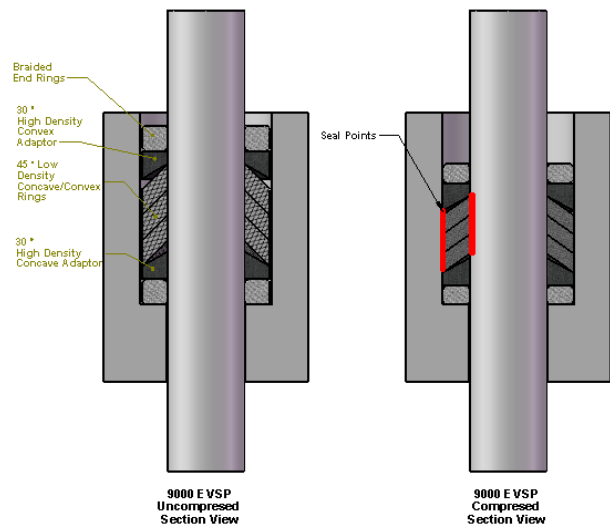

QUICKSET® Emissions Compliant Valve Packing

Garlock QUICKSET is a low emissions alternative specifically designed for shallow stuffing boxes. Like EVSP, QUICKSET offers less than 100 ppm service and exceptionally long life.



Unlike EVSP however, QUICKSET provides low emissions benefits with approximately 20% less stem friction. This results in a more efficient, and therefore less costly, use of plant air and electricity in controlling actuated valves.

Specifications

Construction:	Die-formed cup and cone rings combined with die-formed, high-density Style 1303-Dry end rings with zinc
Temperature:	-328°F (-200°C) to +850°F (+455°C) atmosphere; to +1,200°F (+650°C) steam
pH range:	0-14 (except strong oxidizers)
Pressure:	To 10,000 psi plus (690 bar)

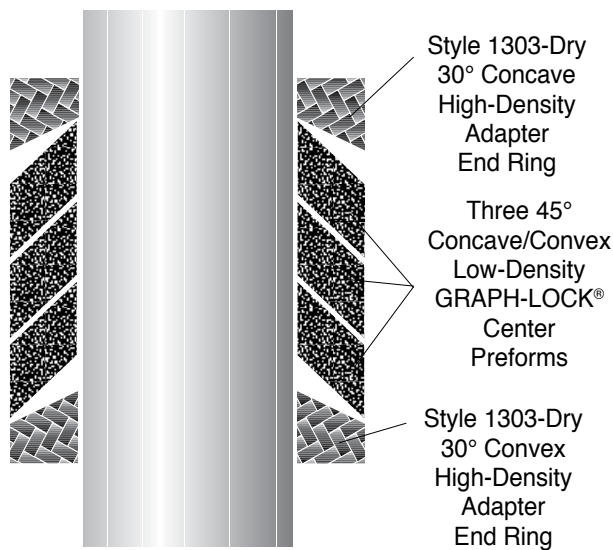

QUICKSET® 9001 Typical Ring Arrangement

Style 1303-FEP

Garlock Style 1303-FEP combines the emissions performance of engineered sets with the installation flexibility and speed that comes from braided packing. Style 1303-FEP offers the same fire safety and chemical resistance as EVSP.



The wire jacketed construction makes for a long lasting valve packing that requires minimal adjustment and will deliver superior emissions control from turn around to turn around. What's more, the wire reinforcement will not score the stem and doesn't add excessive stem friction. In a recent independent API-622 test conducted at Yarmouth Research and Technology, Style 1303-FEP not only provide marked improvement in emissions control, but it also required 60% fewer adjustments and 4% less actuation torque as compared to the next best competitive braided emissions packing.

Specifications

Construction:	High-purity GRAPH-LOCK® flexible graphite and 0.004" INCONEL* filament
Temperature:	-328°F (-200°C) to +850°F (+455°C) atmosphere; to +1,200°F (+650°C) steam
pH range:	0-14 (except strong oxidizers)
Pressure:	To 4,500 psi (310 bar)

*INCONEL® is a registered trademark of Inco Alloys International, Inc.

Valve Packing Accessories

High Purity Carbon Bushings

Our testing has determined that the optimal number of rings to seal a valve stem is between 5 and 7. Any less than 5 rings increases the chance of leaks, any more than 7 puts too much drag on the stem. Garlock uses high purity carbon bushings to shorten deep stuffing boxes like those that are typically found in older valves. When combined with our radially expanding valve stem solutions, our high purity bushings allow excellent sealing with low actuation force which enables old, manual valves to be fit with air actuators and seal like new. Further, our bushings are made to such exacting material and dimensional standards that they can even be certified for nuclear service.

Bushings can also be made from 1303-DRY. While this approach adds some friction to the stem, it is the ideal choice when the valve stuffing box depth cannot be determined prior to repacking.

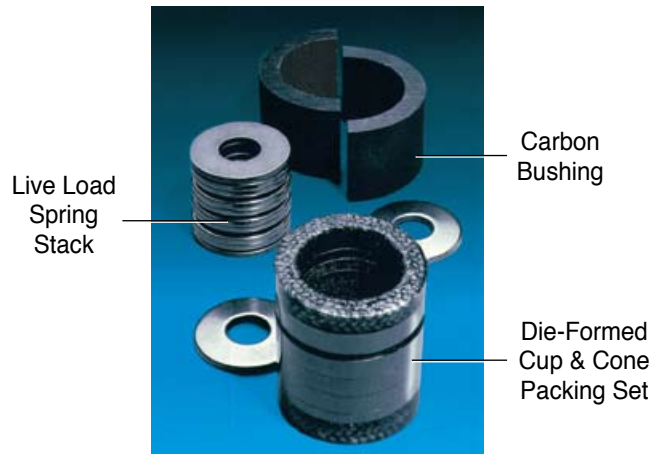

Live Loading Hardware

Even with its densified graphite construction, an EVSP seal can consolidate by up to 2% over its service life. While this is not an issue for valves that can be easily monitored and adjusted, it does pose a problem for valves that are off the routine maintenance path. Additionally some service conditions, like severe temperature swings or frequent opening and closing, can accelerate consolidation. Garlock's solution for those types of applications is Live Loading.

Live Loading can compensate for packing consolidation of up to 3% and, when used with EVSP, can virtually eliminate the need for adjustment. It does not however, put a constant compressive force on the seal. If you use live loading with a braided packing like 1303-FEP, it will significantly extend the time between adjustments but adjustments will still be required.

We stock a wide range of spring washers so we can respond to most needs within 48 hours.

WARNING:

Properties/applications shown throughout this brochure are typical. Your specific application should not be undertaken without independent study and evaluation for suitability. For specific application recommendations consult Garlock. Failure to select the proper sealing products could result in property damage and/or serious personal injury.

Performance data published in this brochure has been developed from field testing, customer field reports and/or in-house testing.

While the utmost care has been used in compiling this brochure, we assume no responsibility for errors. Specifications subject to change without notice. This edition cancels all previous issues. Subject to change without notice.

GARLOCK is a registered trademark for packings, seals, gaskets, and other products of Garlock.

Nuclear Applications

Style G-700

The Choice for Critical Devices

- When used as end rings together with high purity GRAPH-LOCK® rings, G700 is ideal for critical valve applications** in nuclear and power generation industries
- Tested by independent laboratories; compliant with:
 - MIL-P-24583B (SH)
 - General Electric Spec. D50YP12 Rev. 2
- Contains no PTFE or other lubricants
- Non-abrasive; very low coefficient of friction
- Will not fray

Specifications

Construction:	Highest grade graphite filament with an exclusive graphite dispersion, in LATTICE BRAID® construction
Temperature:	-328°F (-200°C) to +1200°F (+650°C) in steam; +1625°F (+900°C) in free oxygen-exclusive environments such as nitrogen and carbon dioxide; +850°F (+455°C) atmosphere
pH range:	0-14 (except strong oxidizers)
Pressure:	To 4,000 psi (275 bar) plus, when used with GRAPH-LOCK® center rings

* INCONEL® is a registered trademark of Inco Alloys International, Inc.
** Used as end rings ONLY.



WARNING:

Properties/applications shown throughout this brochure are typical. Your specific application should not be undertaken without independent study and evaluation for suitability. For specific application recommendations consult Garlock. Failure to select the proper sealing products could result in property damage and/or serious personal injury.

Performance data published in this brochure has been developed from field testing, customer field reports and/or in-house testing.

While the utmost care has been used in compiling this brochure, we assume no responsibility for errors. Specifications subject to change without notice. This edition cancels all previous issues. Subject to change without notice.

GARLOCK is a registered trademark for packings, seals, gaskets, and other products of Garlock.



Seals for Rotating Service

HydraJust™ Engineered Sealing System

—the leak-free, no dilution sealing system designed to replace mechanical seals in industrial pumping applications.

The Best Option for Slurry Service

Garlock has created a long life seal that will increase reliability and process yield while conserving water and energy. Hydra-Just combines the best of both worlds; like a mechanical seal, Hydra-Just provides leak free, no dilution service and saves energy and water because of the low friction design. Like conventional packing, Hydra-Just can accommodate system upsets and is not subject to catastrophic failure.

The Choice for Water Reduction

Up until now, mechanical seals were the most water efficient rotary seal on the market. As a rule of thumb, a mechanical seal requires 1 US gallons per minute per inch of shaft diameter. **Hydra-Just runs with 98% less water than mechanical seals** requiring as little as 3 US gallons per hour. To put this in context, replacing a mechanical seal that requires 2 USGPM of flush with Hydra-Just will save over 1,000,000 US gallons of water per pump.

Designed For Outage-to-Outage Performance

This robust seal enables users to increase profitability through improved process yield. The process exclusive design of the Hydra-Just ensures a seal with the versatility to handle a wide range of system upsets and excel in abrasive slurries. Additionally, the Hydra-Just seal requires no adjustment, freeing up maintenance resources to focus on other areas of the plant.

Easy to Install

Hydra-Just customers can realize production increases by getting back on line faster. The components of the Hydra-Just allow the seal to be installed without uncoupling the motor.

To learn more, visit www.hydrajust.com





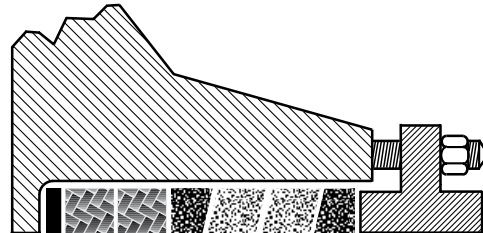

Style 8093 DSA

The Best Option for Clean Service

Garlock's DSA seal is the best available sealing technology for clean media. This leak free seal saves water in that it runs without a flush, improves output by lasting longer than conventional packings and saves money in that it is significantly less expensive than a mechanical seal. Combining these attributes make the Garlock DSA the ideal choice for condensate, water or boiler feed pumps.



-  Gasket spacer (Style 3530 or G-9900)
-  Braided ring (Style 98, 1304, 5000 or 8921-K)
-  Low density GRAPH-LOCK® preforms
-  High density GRAPH-LOCK® adapters

The Right Choice for Water Savings

DSA enables customers to save millions of gallons of water every year. The unique design completely eliminates the need for flush water.

Easy to Install

DSA customers can realize production increases by getting back on line faster. The split design of the seal enables installation in under an hour.

Specifications

Construction:	Typical set: gasket spacer, braided rings, flexible graphite adapters and preforms
Media:	Condensate, boiler feed water, light paper stock, white water, feed water
Temperature:	To +500°F (+260°C)
pH range:	0-14* (except strong oxidizers)
Shaft speed:	To 4,000 fpm plus (20 m/s)
Pressure:	To 500 psi (35 bar)

* Depends on braid choice



Carbon Packings

Long Life Pitch Based Carbon Fiber Packings

Not all carbon fiber packings are created equal. The two attributes that differentiate carbon fiber are purity levels and whether the yarn is made from a continuous filament or from staple fibers. Higher carbon purity improves the temperature and chemical resistance of the braid while the fiber type affects sealing. Simply put, braid constructed from staple fibers conforms to the stuffing box better, requiring lower gland load to make a seal. That lower gland load translates into a packing that will last up to 3 times longer than those made from continuous filaments. It also means that there will be less frictional drag on the shaft which translates to energy savings in rotating equipment and easier operation in valves.

Garlock's styles 98 and 5000 offer energy savings and the benefits of unrivaled service life as compared to other carbon yarns due to their high purity, staple carbon fiber construction.

Style 98

The best choice for high-temperature service

- Low coefficient of friction for longer equipment life
- High thermal conductivity means process runs cooler, and packing lasts longer
- Withstands wide variety of chemicals
- Low chloride certification available



Specifications

Construction:	LATTICE BRAID® carbon fiber
Media:	Acids, strong caustics, hot oils, solvents, boiler feed, condensate water
Equipment:	Centrifugal pumps, agitators, ball, globe, gate and plug valve stems, oil drilling and down-hole tools
Temperature:	-328°F (-200°C) to +850°F (+455°C) atmosphere; to +1,200°F (+650°C) steam
pH range:	0-14 (except strong oxidizers)
Shaft speed:	To 4,000 fpm plus (20 m/s)
Pressure:	To 500 psi (35 bar) rotary/centrifugal; To 2,500 psi (173 bar) valves

Style 5000

The best choice for non-contaminating slurry service



- Low abrasion and high chemical resistance for long service
- Ideal where contamination is prohibited, as in pulp and paper industry
- Low chloride certification available
- Style 5000-PBI* offers extra abrasion resistance

Specifications

Construction:	LATTICE BRAID® carbon fiber impregnated with PTFE, hi-temp break-in lube
Media:	Acids, strong caustics, slurries
Equipment:	Slip joints, mixers, agitators, reactors, autoclaves, centrifugal pumps, turbines
Temperature:	-328°F (-200°C) to +600°F (+315°C)
pH range:	0-14 (except strong oxidizers)
Shaft speed:	To 3,000 fpm plus (15 m/s)
Pressure:	To 500 psi (35 bar) rotary/centrifugal

Soot Blower Sets

CARBAE™ 105 & 108

High performance, low cost

- Excellent cost / use ratio
- Ideal for most industrial equipment
- Compatible with a wide range of chemicals
- Easy to install and remove

Style 105 Specifications

Construction:	95% carbon assay fiber with PTFE coating
Media:	Acids, caustics, slurries
Equipment:	Centrifugal pumps, mixers, agitators
Temperature:	-328°F (-200°C) to +600°F (+316°C) atmosphere; to +1,200°F (+650°C) steam
pH range:	0-14 (except strong oxidizers)
Shaft speed:	To 3,000 fpm (15 m/s)
Pressure:	To 500 psi (35 bar) rotary/centrifugal

Style 108 Specifications

Construction:	95% carbon assay fiber with graphite dispersion
Media:	Acids, caustics, hot oils, solvents, boiler feed, condensate water
Equipment:	Centrifugal pumps, valves, agitators
Temperature:	-328°F (-200°C) to +850°F (+455°C) atmosphere; to +1,200°F (+650°C) steam
pH range:	0-14 (except strong oxidizers)
Shaft speed:	To 4,000 fpm (20 m/s)
Pressure:	To 500 psi (35 bar) rotary/centrifugal; To 2,500 psi (173 bar) valves [†]

[†] No pressure limits have been determined when CARBAE™ 108 is combined as end ring material with die-formed GRAPH-LOCK® center rings in valve installations.

Note: CARBAE™ 108 can be certified to contain less than 200 ppm leachable chlorides on request.

Exceptional reliability

- Rugged materials for extended service life
- INCONEL^{††} wire reinforcement withstands high temperatures and pressures
- Die-formed rings ensure accurate fit and simple installation
- Efficient conical design allows outstanding sealing at low gland loads
- Standard sizes for Diamond Power, Copes Vulcan and other soot blowers

TORNADO PACK™ F1

Construction:	Style 127-AFP: INCONEL wire reinforced carbon over homogeneous core
Temperature:	To +650°F (+345°C) atmosphere, +1,200°F (+650°C) steam

TORNADO PACK™ F3

Construction:	Style 1298: INCONEL wire reinforced PBI ^{†††} over carbon yarn core
Temperature:	To +850°F (+455°C) atmosphere, +1,200°F (+650°C) steam

TORNADO PACK™ F5

Construction:	Style 1303-FEP: INCONEL wire reinforced flexible graphite
Temperature:	To +850°F (+455°C) atmosphere, +1,200°F (+650°C) steam

GRAPH-LOCK® Sets

Construction:	Premium density GRAPH-LOCK® center rings (87.5 lbs/ft ³ [1,400 kg/m ³]) with 1303-FEP or 98 end rings
Temperature:	To +850°F (+455°C) atmosphere, +1,200°F (+650°C) steam

General Device Packing

SYNTHEPAK® Packings

Superior performance

- Unique spun synthetic fiber; ideal replacement for asbestos
- Excellent for pumps, valves, rods, plungers, rams, expansion joints
- Reduction in shaft and sleeve wear lowers operational costs
- Versatile, multi-use packing means lower inventory stocking costs
- See Styles 8909, 8913, 8921-K, 8922, 8922-PBI on pages A-16, A-17 for specifications

Style 1925

Premium performance

- Innovative blend of two yarns:
 - Fiber-infused PTFE yarns offer abrasion resistance and thermal stability
 - Exclusive SYNTHEPAK®* yarns retain flexibility and resilience; ensure even load distribution
- Longer packing and equipment life mean significant cost savings



Specifications

Construction:	LATTICE BRAID® fiber-infused PTFE yarns and SYNTHEPAK® yarns with PTFE dispersion and snow-white petrolatum break-in lube
Equipment:	Pumps
Temperature:	-450°F (-270°C) to +500°F (+260°C)
pH range:	1-13
Shaft speed:	To 2,500 fpm (12 m/s)
Pressure:	To 300 psi (20 bar) rotary/centrifugal

* Patent #4,994,303

Style 1965

Superb flexibility & easy handling

- Protects machinery's critical components from abrasive media
- Lowers maintenance and sealing element expenditures
- Product does not extrude and lasts longer in service
- Material flexibility and easy handling mean faster change-out times
- Non-contaminating components keep end product and pump area clean
- Shock resistant withstanding cavitation, pressure surges and other system upsets
- Increased thermal stability conserves water



Specifications

Construction:	LATTICE BRAID® fiber-infused PTFE yarns* with Graphite and SYNTHEPAK® yarns, PTFE dispersion and snow white petrolatum
Equipment:	Pumps
Temperature:	-450°F (-270°C) to +500°F (+260°C)
pH range:	1-13
Shaft speed:	2,500 fpm (10 m/s)
Pressure:	300 psi (20 bar) rotary/centrifugal

* Patent #4,994,303

PTFE Packings

Style 5888

Valve stem packing with superior chemical resistance

- High density, dimensionally stable—very little water absorption
- Ideal for valve and slower shaft speed applications
- PTFE dispersion ensures a low friction finish and prevents leakage through the braid
- Resistant to most chemicals

Specifications

Construction:	LATTICE BRAID® continuous filament PTFE braid with PTFE dispersion
Equipment:	Check and needle valve stems, reciprocating rods, rams and plungers, and rotary applications
Temperature:	-450°F (-270°C) to +500°F (+260°C)
pH range:	0-14
Shaft speed:	To 1,000 fpm plus (5 m/s)
Pressure:	To 300 psi (20 bar) rotary / centrifugal; To 2,000 psi (138 bar) valves

Note: For oxygen service, specify Style 5898.

Style 5889

Chemically resistant packing for pumps and rotary equipment

- Preshrunk to avoid packing wear and shaft scoring
- Soft, flexible but very nonporous
- Excellent choice for rotary shaft service

Specifications

Construction:	LATTICE BRAID® continuous filament PTFE braid with PTFE dispersion and inert break-in lube
Equipment:	Expansion joints, reciprocating rods, rams, plungers, rotary service
Temperature:	-450°F (-270°C) to +500°F (+260°C)
pH range:	0-14*
Shaft speed:	To 1,500 fpm plus (8 m/s)
Pressure:	To 300 psi (20 bar) rotary/centrifugal

* Not recommended for chlorine service

Style 5904

Food grade packing

- Ideal for food processing applications
- Pliable, wear-resistant and dimensionally stable
- Resists most caustic media
- Rugged and non-toxic
- Ingredients conform to USDA requirements and meet FDA Title 21 CFR 172.878, 177.1550, 178.3570 and 178.3620(a)

Specifications

Construction:	LATTICE BRAID® PTFE filament
Equipment:	Pumps, dryers, cookers, blenders, mixers, and other centrifugal rotary food processing equipment
Temperature:	-450°F (-270°C) to +500°F (+260°C)
pH range:	0-14
Shaft speed:	To 1,500 fpm plus (8 m/s)
Pressure:	To 300 psi (20 bar) rotary/centrifugal



WARNING:

Properties/applications shown throughout this brochure are typical. Your specific application should not be undertaken without independent study and evaluation for suitability. For specific application recommendations consult Garlock. Failure to select the proper sealing products could result in property damage and/or serious personal injury.

Performance data published in this brochure has been developed from field testing, customer field reports and/or in-house testing.

While the utmost care has been used in compiling this brochure, we assume no responsibility for errors. Specifications subject to change without notice. This edition cancels all previous issues. Subject to change without notice.

GARLOCK is a registered trademark for packings, seals, gaskets, and other products of Garlock.

Flush Water Products

Style 1004 Lantern Ring Coil*

Economical and easy to handle

- Costs up to 50% less than OE-supplied lantern rings
- Easily cut with knife or saw, and short lengths splice together, eliminating waste
- Easy to install** and remove from stuffing box—reduces costly downtime
- High-purity PTFE offers chemical resistance in a broad range of rotary services

Specifications

Construction:	Wear-resistant high-grade PTFE
Equipment:	Pumps
Temperature:	To +500°F (+260°C)
pH range:	0-14 (except strong oxidizers)

FLUSH-GARD™ Seal

Reduces flush water

- Throat cavity bushing reduces flush water consumption
- Extends equipment life by protecting sleeve and packing from media attack
- Split design installs easily, without equipment disassembly



Specifications

Construction:	Graphite-filled PTFE
Temperature:	-250°F (-157°C) to +450°F (+232°C)
Surface speed:	To 2,500 fpm (12.7 m/s) [†]
pH range:	0-14 (except strong oxidizers)

* U.S. Patent #4,498,681; Canada Patent #1,271,788

** For maximum strength and density, install with slots toward shaft; for maximum gland water flow, install with slots away from shaft.

† Above 2,500 fpm, consult Garlock.

†† INCONEL is a registered trademark of Inco Alloys International, Inc.

††† PBI is a registered trademark of Celanese Corporation.

Crown Bush Pump Sealing System

Lower your operating costs

- Significantly reduce flush water usage
- Extend packing life
- Reduce sleeve wear
- Flush water distribution optimised to keep contaminants away from the gland packing
- Stainless Steel Crown Bush flow control device resists erosion from abrasive contaminants
- Non-metallic construction available for non-abrasive duties
- Split version available

Applications

- Pulp and paper
- Mining
- Mineral Sands
- Alumina Refining
- Coal Washing



Abrasion Resistant Aramid Fiber Packings

Packmaster 5

This packing, made from aramid fibers that are stronger than steel, will stand up to the toughest abrasive slurries. This style is internally lubricated with silicone making it an economical alternative to other aramid based products.

Specifications

Construction:	Lattice braided Aramid filament lubricated with silicone
Temperature:	-420°F (-250°C) to +500°F (+260°C)
pH range:	2 – 12
Pressure:	To 500 psi (35 bar) rotary
Shaft speed:	To 2500 fpm

For maximum life out of Packmaster 5, use it in conjunction with our Crown Bush throat bushing.

Style 5200

The problem with most aramid fiber packings is that they are designed for strength, not sealability. That's what makes our style 5200 different from other aramid packings; we incorporate a PTFE lubrication system that makes a better pump shaft seal. The result is that less abrasive material makes it into the stuffing box so that pumps packed with 5200 can stay in service longer and help our customers realize the benefits that come from increased process yield and improved reliability.

Specifications

Construction:	Lattice braided Aramid filament lubricated with a PTFE
Temperature:	-420°F (-250°C) to +500°F (+260°C)
pH range:	2 – 12
Pressure:	To 500 psi (35 bar) rotary
Shaft speed:	To 2500 fpm

WARNING:

Properties/applications shown throughout this brochure are typical. Your specific application should not be undertaken without independent study and evaluation for suitability. For specific application recommendations consult Garlock. Failure to select the proper sealing products could result in property damage and/or serious personal injury.

Performance data published in this brochure has been developed from field testing, customer field reports and/or in-house testing.

While the utmost care has been used in compiling this brochure, we assume no responsibility for errors. Specifications subject to change without notice. This edition cancels all previous issues. Subject to change without notice.

GARLOCK is a registered trademark for packings, seals, gaskets, and other products of Garlock.

Style Index

Style	Material Classification	Lubrication	Construction	Service		
				Rotary	Recip.	Valve
18	Flax roving	Petrolatum & paraffin	Square braid	X	X	
90	Flax roving	Marine & petro wax/graphite	Square braid	X	X	
98	Carbon filament	Graphite dispersion	LATTICE BRAID®	X	X	X
98-PBI ¹	Carbon filament	Graphite dispersion	LATTICE BRAID®	X	X	
105 (CARBAE™)	Carbon filament	PTFE & snow-white petrolatum	LATTICE BRAID®	X		
108 (CARBAE™)	Carbon filament	Graphite dispersion	LATTICE BRAID®	X	X	X
127-AFP	INCONEL ³ wire-reinforced spun carbon over homogeneous core	Graphite	Braid over core			X
G-200	Graphite filament	Graphite dispersion	LATTICE BRAID®	X		
G-700 ⁴	Graphite filament	Graphite	LATTICE BRAID®			X
740	Flax roving	Petrolatum & marine wax	LATTICE BRAID®	X	X	
745	Flax roving	Petrolatum, marine wax, & graphite	LATTICE BRAID®	X	X	
1298	INCONEL wire-reinforced PBI over carbon yarn core	Graphite & tungsten disulfide	Braid over core			X
1300-E	Flexible graphite	None	Square braid	X		X
1303-FEP	INCONEL filament-reinforced flexible graphite	Graphite dispersion	Square braid			X
1333-G	Graphite filament-reinforced flexible graphite	Graphite	Square braid	X		X
1812	Spun NOMEX ⁵ / synthetic	PTFE & snow-white petrolatum	LATTICE BRAID®	X	X	
1850	KYNOL ⁶	PTFE & snow-white petrolatum	LATTICE BRAID®	X	X	
1925	Fiber-infused PTFE	PTFE suspensoid and snow-white petrolatum	LATTICE BRAID®	X		
1965	Fiber-infused PTFE	Graphite	LATTICE BRAID®	X		
5000	Carbon filament	PTFE & snow-white petrolatum	LATTICE BRAID®	X	X	
5000-PBI	Carbon filament w/ PBI corners	PTFE & snow-white petrolatum	LATTICE BRAID®	X	X	
5100	GFO ⁷	Silicone	LATTICE BRAID®	X		X
5200	Aramid filament	PTFE dispersion	LATTICE BRAID®	X	X	
5413	Flax roving	PTFE & snow-white petrolatum	Square braid	X	X	
5450	Fiberglass	None—Graphite on request	LATTICE BRAID®			
5481	Fiberglass	None—Graphite on request	Round braid			

1. PBI is a registered trademark of Celanese Corporation.

2. VITON is a registered trademark of DuPont Dow Elastomers

3. INCONEL is a registered trademark of Inco Alloys International, Inc.

4. To be used as end ring material only with GRAPH-LOCK® center rings.

5. NOMEX is a registered trademark of DuPont.

6. KYNOL is a trademark of American Kynol, Inc.

* 0-14 except strong oxidizers

Temperature		Pressure (psi)		Pressure (bar)		Shaft Speed		pH
Fahrenheit	Centigrade	Rotary	Valve	Rotary	Valve	fpm	m/s	
To +220°	To +105°	150		10		1,200	6	5-9
To +220°	To +105°	300		20		1,200	6	5-9
-328° to +850° atmosphere +1,200° steam	-200° to +455° atmosphere +650° steam	500	2,500	35	173	4,000	20	0-14*
To +650° atmosphere	To +345° atmosphere	500		35		4,000	20	1-12
-328° to +600° atmosphere	-200° to +316° atmosphere	500		35		3,000	15	0-14*
-328° to +850° atmosphere +1,200° steam	-200° to +455° atmosphere +650° steam	500	2,500	35	173	4,000	20	0-14*
+850° atmosphere +1,200° steam	+455° atmosphere +650° steam		1,200		82			1-12
-328° to +850° atmosphere +1,200° steam	-200° to +455° atmosphere +650° steam	500		35		4,000	20	0-14*
To +850° atmosphere +1,200° steam	To +455° atmosphere +650° steam		4,000		275			0-14*
To +220°	To +105°	150		10		1,200	6	5-9
To +220°	To +105°	250		17		1,200	6	5-9
To +850° atmosphere +1,200° steam	To +455° atmosphere +650° steam		4,500		310			1-12
-328° to +850° atmosphere +1,200° steam	-200° to +455° atmosphere +650° steam	500	3,000	35	200	4,000	20	0-14*
-328° to +850° atmosphere +1,200° steam	-200° to +455° atmosphere +650° steam		4,500		310			0-14*
-328° to +850° atmosphere +1,200° steam	-200° to +455° atmosphere +650° steam	500	4,000	35	275	4,800	23	0-14*
-170° to +500°	-110° to +260°	300		20		2,000	10	1-12
-170° to +500°	-110° to +260°	500		35		2,000	10	1-13
-450° to +500°	-270° to +260°	300		20		2,500	12	1-13
-450° to +500°	-270° to +260°	300		20		2,500	12	1-13
-328° to +600°	-200° to +315°	500		35		3,000	15	0-14*
-328° to +600°	-200° to +315°	500		35		3,000	15	1-12
-200° to +550°	-130° to +288°	300	2,000	20	138	4,000	20	0-14*
-420° to +500°	-250° to +260°	500		35		2,500	12	2-12
To +250°	To +120°	200		14		1,200	6	5-9
To +1000°	To +540°		10		1			2-11
To +1000°	To +540°		10		1			2-11

WARNING:

Properties/applications shown throughout this brochure are typical. Your specific application should not be undertaken without independent study and evaluation for suitability. For specific application recommendations consult Garlock. Failure to select the proper sealing products could result in property damage and/or serious personal injury.

Performance data published in this brochure has been developed from field testing, customer field reports and/or in-house testing.

While the utmost care has been used in compiling this brochure, we assume no responsibility for errors. Specifications subject to change without notice. This edition cancels all previous issues. Subject to change without notice.

GARLOCK is a registered trademark for packings, seals, gaskets, and other products of Garlock.

Style Index (cont'd)

Style	Material Classification	Lubrication	Construction	Service		
				Rotary	Recip.	Valve
5888	PTFE filament	PTFE suspensoid	LATTICE BRAID®	X	X	X
5889	PTFE filament	PTFE dispersion & silicone	LATTICE BRAID®	X		
5898	PTFE filament	PTFE dispersion	LATTICE BRAID®			X
5904	PTFE filament—FDA	PTFE dispersion / mineral oil	LATTICE BRAID®	X	X	
8091 HYDRA- JUST	Dynamic Rotary Sealing Solution	N/A	GYLON® & Graphite Braid with Graphite Cup & Cone	X		
8093 DSA	Flexible graphite	N/A	Die-formed sets	X		
8094 DSA	Flexible graphite / Model 26	N/A	Die-formed sets	X		
8909	Spun synthetic	Graphite & petrolatum	Square braid	X		
8913	Spun synthetic	Graphite & petrolatum	LATTICE BRAID®	X		
8921-K	Spun synthetic—aramid filament corners	PTFE suspensoid & snow-white petrolatum	LATTICE BRAID®	X	X	X
8922	Spun synthetic	PTFE suspensoid & snow-white petrolatum	LATTICE BRAID®	X	X	X
8922-PBI	Spun synthetic / PBI corners	PTFE suspensoid & snow-white petrolatum	LATTICE BRAID®	X	X	
9000 EVSP	Flexible graphite	N/A	Die-formed sets			X
QUICKSET® 9001	Flexible graphite	N/A	Die-formed sets			X
F1	INCONEL ³ wire-reinforced spun carbon over homogeneous core	Graphite & zinc	Die-formed sets			Soot blower
F3	INCONEL wire-reinforced PBI ¹ over carbon yarn core	Graphite & tungsten disulfide	Die-formed sets			Soot blower
F5	INCONEL wire-reinforced spun flexible graphite	Graphite dispersion	Die-formed sets			Soot blower
GRAPH- LOCK®	Flexible graphite	N/A	Die-formed sets, tape	X		X
PM [†] -1	Spun synthetic	PTFE suspensoid & snow-white petrolatum	LATTICE BRAID®	X		
PM-2	Spun synthetic	Petroleum oils & graphite	LATTICE BRAID®	X		
PM-3	Spun synthetic	Petroleum oils & graphite	Square braid	X		
PM-5	Aramid filament	Silicone	LATTICE BRAID®	X	X	
PM-6	Expanded PTFE/graphite	Silicone	LATTICE BRAID®	X		
PM-6K	Expanded PTFE filament— aramid filament corners	Silicone	LATTICE BRAID®	X	X	
PM-7	PTFE filament	PTFE suspensoid	LATTICE BRAID®	X	X	X
PM-8	PTFE filament	Silicone	LATTICE BRAID®	X		

1. PBI is a registered trademark of Celanese Corporation.
2. VITON is a registered trademark of DuPont Dow Elastomers
3. INCONEL is a registered trademark of Inco Alloys International, Inc.
4. To be used as end ring material only with GRAPH-LOCK® center rings.
5. NOMEX is a registered trademark of DuPont
6. KYNOL is a trademark of American Kynol, Inc.
7. GFO is a trademark of WL Gore.

- * 0-14 except strong oxidizers
- ** Should not be used in chlorine
- *** Pressure and shaft speeds controlled by types of braid used in conjunction with the GRAPH-LOCK® product
- † PM = PACKMASTER®

	Temperature		Pressure (psi)		Pressure (bar)		Shaft Speed		pH
	Fahrenheit	Centigrade	Rotary	Valve	Rotary	Valve	fpm	m/s	
-450° to +500°	-270° to +260°		300	2,000	20	138	1,000	5	0-14
-450° to +500°	-270° to +260°		300		20		1,500	8	0-14**
-450° to +500°	-270° to +260°		300	2,000	20	138	1,000	5	0-14
-450° to +500°	-270° to +260°		300		20		1,500	8	0-14
To 500°F	200°C		500		35		4,000	20	0-14
To +500°	To +260°		500		35		4,000	20	0-14*
To +200°	To +93°		300		20		4,000	20	2-12
-170° to +500°	-110° to +260°		300		20		1,500	8	4-10
-170° to +500°	-110° to +260°		300		20		1,500	8	4-10
-170° to +550°	-110° to +288°		500	2,500	35	173	2,250	11	0-12
-170° to +550°	-110° to +288°		500	2,500	35	173	2,500	12	0-12
-170° to +550°	-110° to +288°		500		35		2,250	11	1-12
-328° to +850° atmosphere +1,200° steam	-200° to +455° atmosphere +650° steam			10,000		690			0-14*
-328° to +850° atmosphere +1,200° steam	-200° to +455° atmosphere +650° steam			10,000		690			0-14*
To +650° atmosphere +1,200° steam	To +345° atmosphere +650° steam								1-12
To +850° atmosphere +1,200° steam	To +455° atmosphere +650° steam								1-12
To +850° atmosphere +1,200° steam	To +455° atmosphere +650° steam								0-14
-328° to +850° atmosphere +1,200° steam	-200° to +455° atmosphere +650° steam		***	***	***	***	***	***	0-14*
-170° to +500°	-110° to +260°		300		20		1,500	8	4-10
-170° to +500°	-110° to +260°		300		20		1,500	8	4-10
-170° to +500°	-110° to +260°		200		14		1,000	5	4-10
-420° to +500°	-250° to +260°		500		35		2,500	12	2-12
-200° to +550°	-130° to +288°		300		20		3,000	15	0-14**
-200° to +550°	-130° to +288°		500		35		1,900	10	3-12
-450° to 500°	-270° to +260°		300	2,000	20	138	1,000	5	0-14
-450° to 500°	-270° to +260°		300		20		1,500	8	0-14**

WARNING:

Properties/applications shown throughout this brochure are typical. Your specific application should not be undertaken without independent study and evaluation for suitability. For specific application recommendations consult Garlock. Failure to select the proper sealing products could result in property damage and/or serious personal injury.

Performance data published in this brochure has been developed from field testing, customer field reports and/or in-house testing.

While the utmost care has been used in compiling this brochure, we assume no responsibility for errors. Specifications subject to change without notice. This edition cancels all previous issues. Subject to change without notice.

GARLOCK is a registered trademark for packings, seals, gaskets, and other products of Garlock.

Packing Materials

Aramid

These fibers are aromatic polyamides that were given the generic name “aramid.” With excellent resistance to high temperatures and exceptional tensile strength, aramid filaments are considered to be stronger, pound for pound, than steel. Garlock utilizes a variety of these fibers including spun and filament versions. Filament yarns are added to the corners of pump packings for greater resistance to abrasive media.

Carbon/Graphite Filament Packings

Garlock carbon filament products are made from carbon yarns having a 95% minimum carbon assay. Premium products (Styles 98, 98-VC and 5000) use pitch-based yarns, while CARBAE™ Styles 105 and 108 are made from P.A.N.* base yarns. Low friction coefficients are standard for less shaft wear and lower maintenance and replacement costs. Garlock carbon fibers also offer more value per pound than other packings.

Garlock graphite filament products are braided from high-purity graphite filaments with a minimum carbon assay of 99%. They have excellent chemical resistance, are thermally conductive and can be used in extreme temperature and pressure conditions.

Fiberglass

Glass fibers exhibit superior thermal properties, dimensional stability and tensile strength. Glass fibers will not burn, and they dissipate heat more rapidly than organic fibers. The glass fibers most commonly used in compression packings are “E” grade (electrical) and “S” grade (strength). Common solvents, oils, petroleum distillates, bleaches and most organic chemicals do not affect fiberglass.

Flax

Garlock carefully selects quality long-fiber roving yarns, braids them, and then thoroughly impregnates them with the required lubricating agents. They are designed for optimum service in waste and dilute aqueous solutions up to +250°F (+121°C) at low to medium pressures. Industries such as mining, milling, steel, waste/water treatment, marine, and pulp and paper regularly specify these packings for their operations.

GRAPH-LOCK® Products

Made of extremely pure graphite, Garlock GRAPH-LOCK® packing products offer unmatched service in industrial environments where searing temperatures and crushing pressures cause constant failure of conventional packings.

Flexible Graphite Tape Products

GRAPH-LOCK® is self-lubricating, dimensionally stable, impervious to gases and fluids, and corrosion-resistant. GRAPH-LOCK® products offer excellent sealing capabilities under extreme conditions for longer equipment life and less maintenance. It is available in tape and die-formed rings from Garlock Compression Packing and in sheet form from Garlock Sheet Products.

Garlock Compression Packing offers two purity levels of our GRAPH-LOCK® products—commercial grade of 95% and nuclear grade of 99.5%. The nuclear grade material meets General Electric Spec. D50YP12, Rev. 2 dated Oct. 1992; MIL-P-24503B (SH); and can be certified for oxygen service.

Flexible Graphite Braided Products

Garlock offers a variety of high-purity braided flexible GRAPH-LOCK® products as well. We offer a plain braided graphite version (1300), INCONEL** wire-reinforced versions (1303-FEP, 1398, 1399), an aramid-reinforced version (1304), and a graphite filament-reinforced version (1333-G).

MILL-RIGHT® Products

The experience gained over 100 years as a manufacturer has enabled Garlock to develop “Tough Technology” for the MILL-RIGHT® family of packings. Fiber-infused technology starts with yarns produced at our own facility. With the addition of an exclusive blocking and lubricating system, Garlock non-contaminating packings can resist abrasion without being abrasive to equipment and perform successfully throughout a broad range of industries and applications.

* P.A.N.: poly-acrylo-nitrile

** INCONEL is a registered trademark of Inco Alloys International, Inc.

PBI

PBI is a registered trademark of Celanese Corporation, and is an acronym for the term “polybenzimidazole”, a high performance organic fiber. PBI fibers maintain dimensional stability at high temperatures and are compatible in a wide range of chemicals and solvents. Garlock incorporates wire-reinforced PBI yarns in valve stem packings as well as adding spun filament yarns to the corners of pump packings for added strength and abrasion resistance.

PTFE Packings

Garlock starts with the advantage of PTFE—excellent chemical resistance, a wide temperature range, flexibility with toughness—and combines them with the superior LATTICE BRAID® construction to form adaptable, effective packings. High in quality and consistently uniform, they are used extensively in the food processing, chemical, agricultural and petroleum processing industries.

SYNTHEPAK® Products

SYNTHEPAK® packings are a family of remarkable spun synthetic fiber packings created and developed by Garlock for low-cost general industrial service. Since they undergo the same braiding and treatment process as asbestos packings, SYNTHEPAK® packings make an excellent replacement for asbestos. This extremely adaptable fiber has proved superior to many types of conventional packings.

XPG

The expanded PTFE/Graphite (XPG) yarn system is a unique blend of expanded PTFE filament with a blend of micronized graphite powder. The yarn utilizes a high temperature silicone oil lubricant. It can be used through an extremely wide range of applications including acids, alkalies, aromatic and aliphatic solvents, alcohols, esters, petroleum and synthetic oils, steam, water and aqueous solutions, and air and dry industrial gases.

XPG features good thermal conductivity, speed capability, chemical resistance, low coefficient of friction and low coefficient of thermal expansion, making it excellent for use in pumps, mixers and agitators.

WARNING:

Properties/applications shown throughout this brochure are typical. Your specific application should not be undertaken without independent study and evaluation for suitability. For specific application recommendations consult Garlock. Failure to select the proper sealing products could result in property damage and/or serious personal injury.

Performance data published in this brochure has been developed from field testing, customer field reports and/or in-house testing.

While the utmost care has been used in compiling this brochure, we assume no responsibility for errors. Specifications subject to change without notice. This edition cancels all previous issues. Subject to change without notice.

GARLOCK is a registered trademark for packings, seals, gaskets, and other products of Garlock.

Construction

Compression packings are made in a variety of shapes, sizes and constructions, from a wide range of materials. The following describes the most commonly-used constructions, and the advantages of each.

Braid-Over-Braid (Figure 1)

Round braiding machines braid tubular jackets using yarns, rovings, ribbons and various other materials, either alone or in combination. Size is obtained by braiding jackets one over the other (braid-over-braid). Finished packings can be supplied in round, square or rectangular cross section. Braid-over-braid packings, also known as round braid or multiple braid packings, are relatively dense and are recommended for high-pressure, slow-speed applications such as valve stems, expansion joints, groove gasketing, etc.

Braid-Over-Core (Figure 2)

Finished product is produced by round braiding one or more jackets of yarns, rovings, ribbons or other forms of various materials over a core, which may be extruded, twisted, wrapped or knitted. This construction allows for a wide range of densities and different cross sectional shapes.

Square Braid (Figure 3)

Yarns, rovings, ribbons and other various materials, either alone or in combination, are processed on equipment where strands pass over and under strands running in the same direction. Resulting packings are usually supplied in square cross section, but rectangular sizes can also be braided by this method. The packing is usually soft and can carry a large percentage of lubricant. Square braided packings are easy on equipment and are generally used for high-speed rotary service at relatively low pressure. The packing's softness makes it ideal for old or worn equipment.

LATTICE BRAID® (Figure 4)

Yarns, rovings, ribbons and other forms of various materials, either alone or in combination, are processed on equipment where the strands crisscross from the surface diagonally through the body of the packing. Each strand is strongly locked by other strands to form a solid integral structure that cannot easily ravel or come apart in service. There are no jackets to wear through, and no plaits to come loose. LATTICE BRAID® packing has a more even distribution of yarn density throughout and has the potential for improved lubricant retention. The finished packing is relatively dense, but flexible.



Figure 1



Figure 2



Figure 3



Figure 4

LATTICE BRAID® packings are suitable for applications on both reciprocating and centrifugal pumps, agitators, valves, expansion joints and in grooves.

Die-Formed

Many compression packing materials can be supplied in a pre-compressed ring form, which provides controlled density and size.

Mandrel Cut

Rings formed by wrapping braided stock of the required cross section on a mandrel or shaft with a diameter equal to the desired I.D.

Graphite Tape

Flexible graphite tape (ribbon) is manufactured by exfoliating (expanding) and then compressing natural graphite flakes to a specific density. Graphite has almost universal chemical inertness and is naturally lubricious, compactible and resilient, as well as nuclear radiation resistant.

Flexible graphite tape can be die-molded or compressed to form endless true labyrinth rings. Graphite tape packings have a low coefficient of friction, a pH range of 0-14 and are noted for their excellent thermal properties enabling them to be used in applications to 5500°F (3000°C) in non-oxidizing atmospheres. Due to their temperature resistance and density, they make ideal valve packings in steam, VOC, hydrocarbons or chemical applications when used in combination with braided end rings such as Styles 1303-FEP, 98 or G-700.

Material Selection

The proper selection of packing materials is dependent on the operating conditions of the equipment. Six parameters of the equipment must be determined before a proper packing recommendation can be made. The acronym "STAMPS" is commonly used to designate these parameters:

Lubricants

Lubricants are usually added to compression packings when the packings are to be used on rotary equipment where frictional heat is generated. The lubricants provide a resiliency that allows the packing to deform and recover under slight mechanical deficiencies such as shaft deflection. They may also provide interfiber lubricity that reduces frictional heat.

Blocking Agents

Lubricants that act as a fluid barrier by closing the voids that are present in braided materials to prevent leakage through the cross section of the packing.

Single End Coating

A proprietary Garlock process that coats each yarn used in packing prior to the braiding process. This provides a more consistent coating of packing materials for better sealing.

S = Size — cross section

T = Temperature — of media being sealed

A = Application — type of equipment (i.e., pumps, valves, mixers, etc.)

M = Media — material being sealed

P = Pressure — of media being sealed

S = Speed — shaft speed in fpm (pumps only)

Equipment Condition

No matter what type of equipment you are trying to seal, the condition of the equipment is critical to the success of the packing. Garlock recommends:

Valves

- **Longitudinal scores** on the valve stem are not to exceed 1/32" depth and/or a depth-to-width ratio greater than 1.00.
- **Stem finish** no greater than 32 (micro inches) AARH.
- **Stuffing box finish** is recommended to be 125 (micro inches) AARH.
- **Valve stem warpage / runout** must be checked and found not to exceed:

Stem Diameter	Runout (TIR / ft)
Up to and including 1.500" (38.1 mm)	±0.010"
1.501" to 3.000" (38.1 mm to 76.2 mm)	±0.020"
3.001" (76.2 mm) and above	±0.040"

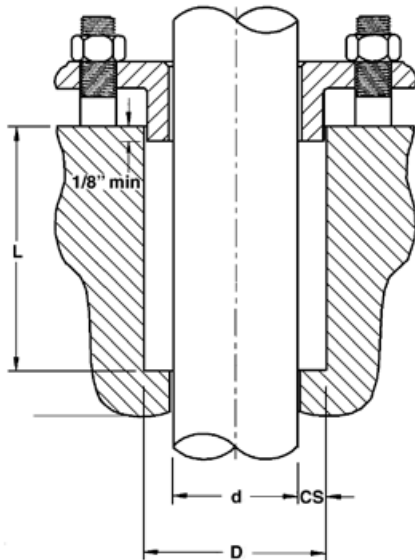

Stuffing box dimensions

- The bottom of the gland follower should be flat. If box bottom is beveled, Garlock recommends the use of a system-compatible braided packing ring to be installed before the bushing.
- Stuffing box should contain no burrs on the stem and/or box bore walls.

Pumps

- **Runout:** TIR (Total Indicator Runout) not to exceed 0.005".
- **Longitudinal scores:** none should be present on pump shaft or sleeve.

Shaft Diameter		Recommended Cross Section (CS)	
Inches	mm	Inches	mm
5/8" to 1-1/8"	(15.8 to 28.6)	5/16"	(7.9)
Over 1-1/8" to 1-7/8"	(28.6 to 47.6)	3/8"	(9.5)
Over 1-7/8" to 3"	(47.6 to 76.2)	1/2"	(12.7)
Over 3" to 4-3/4"	(76.2 to 120.7)	5/8"	(15.8)
Over 4-3/4" to 12"	(120.7 to 304.8)	3/4"	(19.0)

$$D = d + (2 \times CS)$$

- **Recommended box depth (L) = (5.5 to 7.5) x CS**
- **Recommended surface finishes:**
 Stem / Sleeve: 16 to 32 (micro inches) AARH
 Box Bore: 125 (micro inches) AARH

WARNING:

Properties/applications shown throughout this brochure are typical. Your specific application should not be undertaken without independent study and evaluation for suitability. For specific application recommendations consult Garlock. Failure to select the proper sealing products could result in property damage and/or serious personal injury.

Performance data published in this brochure has been developed from field testing, customer field reports and/or in-house testing.

While the utmost care has been used in compiling this brochure, we assume no responsibility for errors. Specifications subject to change without notice. This edition cancels all previous issues. Subject to change without notice.

GARLOCK is a registered trademark for packings, seals, gaskets, and other products of Garlock.

Installation Instructions

Valve Stem Packing

1. Remove all of the old packing from the stuffing box. Clean box and stem thoroughly and examine stem for wear and scoring. Replace stem if wear is excessive. Recommended surface finishes are 32 (micro inches) AARH on the stem, and 125 (micro inches) AARH maximum on the box bore.
2. Measure and record stem diameter, stuffing box bore and box depth. To determine the correct packing size, measure the diameter of the stem (inside the stuffing box area if possible), and the diameter of the stuffing box bore. Subtract the I.D. measurement from the O.D. measurement, and divide the difference by two. This is the required cross-sectional size.
3. Always cut the packing into individual rings. Never wind the packing into a coil in the stuffing box. Rings should be cut with a butt joint. Cut rings by using a spare stem, a mandrel with the same diameter as the stem or a packing cutter. The illustration shows how to use a mandrel to cut packing.

Hold the packing tightly on the mandrel, but do not stretch excessively. Cut the ring and insert it into the stuffing box, making certain that it fits the packing space properly. Each additional ring can be cut in the same manner.
4. Install one ring at a time. Make sure it is clean, and has not picked up any dirt in handling. Seat each ring firmly, making sure it is fully seated before the next ring is installed. Joints of successive rings should be staggered and kept at least 90° apart. When enough rings have been individually seated so that the nose of the gland follower will reach them, individual tamping of the rings should be supplemented by the gland follower. Bring down the gland follower and apply load with the gland bolts.
5. After the last ring is installed, bring down the gland follower and apply 25% to 35% compression to the entire packing set. If possible, record the gland nut torque values and actuate the valve through five (5) complete cycles (ending with the stem in the down position). Retighten the gland bolt nuts to the pre-viously recorded torque value after each full actuation.

Step 1

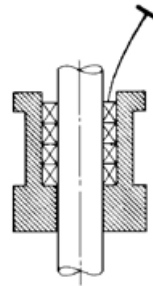

Step 2

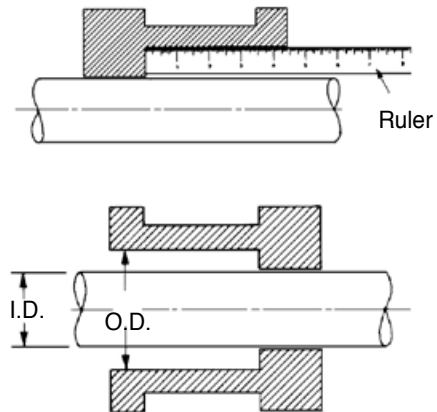

Step 3

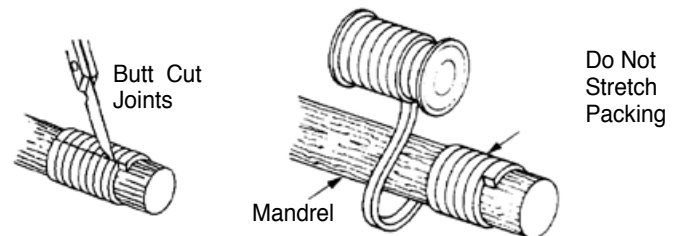

Steps 4 and 5

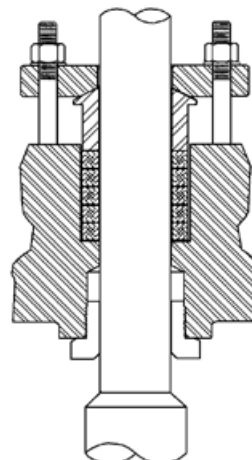

Pump Packing

1. Remove all the old packing with packing hooks, being careful not to damage the shaft or sleeve. This means all rings, even the lantern ring and the rings below the lantern. Clean the stuffing box and examine the shaft and sleeve. Replace any worn parts that are scored or deeply grooved.
2. Measure and record shaft diameter, stuffing box bore and box depth. To determine the correct packing size, measure the diameter of the shaft and the stuffing box bore. Subtract the shaft diameter from the bore diameter and divide the difference by two. This is the required cross-sectional size.

3. Always cut the packing into individual rings. Never wind the packing into a coil in the stuffing box. Rings should be cut with a butt joint. Cut rings by using a mandrel with the same diameter as the shaft in the stuffing box area. If there is no wear, rings can be cut on the shaft outside the stuffing box.

Hold the packing tightly on the mandrel, but do not stretch excessively. Cut the ring and insert it into the stuffing box, making certain that it fits the packing space properly. Each additional ring can be cut in the same manner.

4. Install one ring at a time. Make sure it is clean, and has not picked up any dirt in handling. Lubricate the I.D. of each ring lightly. Start one end and then the other, butted closely. Work around circumference from either or both directions. Joints of successive rings should be staggered and kept at least 90° apart. Each individual ring should be firmly seated with a tamping tool. When enough rings have been individually seated so that the nose of the gland follower will reach them, individual tamping should be supplemented by the gland.

5. If a lantern ring is provided, make sure the lantern ring is installed under the pipe tap hole.

6. After the last ring is installed, bring the follower down on the packing and finger-tighten the gland nuts. Do not jam the packing by excessive gland loading. Start pump, and tighten the bolts until leakage is decreased to a tolerable minimum. Make sure gland bolts are tightened evenly. Stopping leakage entirely at this point will cause the packing to burn up.

7. Allow packing to leak freely upon startup after repack. Gradually reducing leakage during the first hour of operation will result in a better seal over a longer period of time. Tighten the gland nuts one flat at a time until the desired leakage is obtained, and the pump is running cool.

Step 1

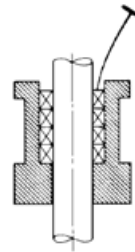

Step 2

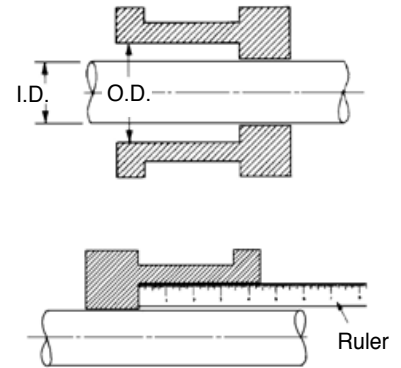

Step 3

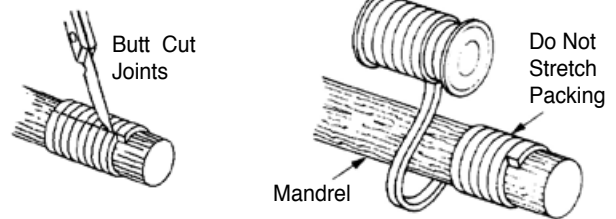

Steps 5 and 6

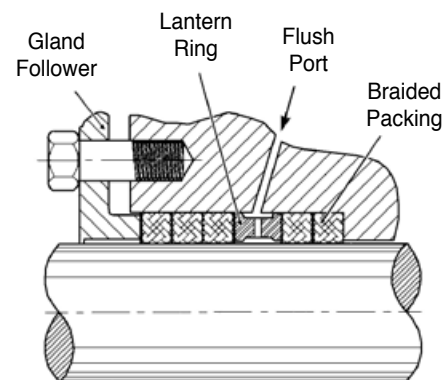

Testing

Functional Testing

Pump Test Fixtures

Garlock Compression Packing has three different pump test fixture designs used for evaluating pump packing set types and arrangements.

Media: Ambient temperature water
Note: The end suction pump system, due to the dynamics of a closed loop system, can produce water temperatures as high as 160°F (70°C).

Abrasives: Can be introduced into the end suction pump system

Shaft Speeds: From 367 fpm to 2,100 fpm (1.63 m/s to 9.33 m/s)

Packing cross sections: Typically 3/8" (9.5 mm) cross section, but modifications can be made to test up to 5/8" (15.8 mm) cross section.

Stuffing box pressures: 2 psi to 120 psi (0.1 to 8.3 bar)

Note: Pressures above 60 psi (4.1 bar) are achieved by throttling down the discharge flow in the end suction pump.

Stuffing box depths: 1.500" to 2.250" (38.1 mm to 57.2 mm)

High Temperature / Pressure Valve Test Fixtures

The basic design layout for this fixture was produced by Dayton T. Brown (an independent test laboratory in Bohemia, New York) for sanctioned qualification testing by the U.S. Military. Of four test valve positions, two use custom-made valve bonnets in MOV-type test scenarios, and two are standard production block valve bonnets that are hand-actuated.



Garlock Valve Test Fixture

Material Testing

Material Testing Laboratory

The various testing capabilities are often used to check conformance to ISO material and processing specification requirements.

The Garlock Compression Packing facility has the capability to perform a range of in-house chemical and physical testing exercises. These tests are used to qualify or to check the conformance of incoming raw materials as an aid to in-process checks, or as a final qualification check to ensure that finished products meet the customer's agreed-upon specifications. Whenever possible and practical, Garlock performs its testing programs in conformance with existing ASTM procedures.

Examples of testing capabilities are:

- Wet chemical testing
- Weight loss determination
- Exposure—radiation, argon, etc.
- Yields—braid, ring
- Tensile strength
- Density determinations

WARNING:

Properties/applications shown throughout this brochure are typical. Your specific application should not be undertaken without independent study and evaluation for suitability. For specific application recommendations consult Garlock. Failure to select the proper sealing products could result in property damage and/or serious personal injury.

Performance data published in this brochure has been developed from field testing, customer field reports and/or in-house testing.

While the utmost care has been used in compiling this brochure, we assume no responsibility for errors. Specifications subject to change without notice. This edition cancels all previous issues. Subject to change without notice.

GARLOCK is a registered trademark for packings, seals, gaskets, and other products of Garlock.

Gasket Spacers

Gasket spacers are used in conjunction with braided packing rings to:

- Close up the clearances around the inside diameter of the packing set, keeping solid particles from progressing through the packing set along with the liquid leakage
- Act as a throttle bushing and reduce the pressure on the outboard side of the spacer, in applications where the leakage rate is relatively high
- Keep the packing from extruding beyond the stuffing box bottom, where there are excessive clearances between the I.D. of the stuffing box bottom and the shaft O.D. (This problem may occur through wear, corrosion, or simply the way a piece of equipment is manufactured)

In applications involving high stuffing box pressures (particularly reciprocating pumps) gasket spacers are also used to:

- Reduce the amount of leakage that occurs through the body of the braid, by forcing leakage to the I.D. of the packing set and eliminating O.D. leakage
- Keep the packing square, restrict packing movement, and prevent packing rollover and premature failure caused by excessive frictional forces

Stealth Packing Set* Option

- Optimal dry running situation—eliminate flush and lantern ring
- Combines Garlock Style 3530 GYLON® spacers with Style 1304 or 1333-G cut rings
- Contact Applications Engineering for details

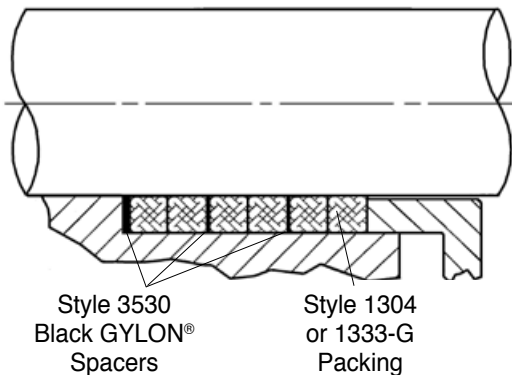

Stealth Packing Set Spacer and Ring Arrangement

* Patent pending

Gland Load

Garlock recommends using one of these two methods to determine the proper gland load on a valve packing set.

Percent Compression Method

This method simply determines the distance the set should be compressed in order to achieve a seal. The recommended percent compression varies with packing style.

- | | |
|---|-----------------|
| ▪ 9000-EVSP Simplified | 30% compression |
| QUICKSET® 9001 | 30% compression |
| ▪ 70#/ft ³ density GRAPH-LOCK® | 25% compression |
| 70#/ft ³ density #98 sets | 25% compression |
| ▪ 90#/ft ³ density GRAPH-LOCK® | 20% compression |
| 90#/ft ³ density #98 sets | 20% compression |
| ▪ Garlock braided packing only | 25% compression |

In cases where the system pressure is very high (over 2,500 psi or 72 bar), higher compression may be required to achieve a seal.

Predetermined gland bolt torque method

This method determines a more precise gland load. The bolt torque depends upon packing size, gland bolt size, packing style system pressure, and the number of bolts. The gland studs and nuts must be in good condition, cleaned with a wire brush and well-lubricated with a suitable grease.

Use the following equation to determine the appropriate bolt torque:

$$\text{Bolt torque} = \frac{(\text{Bore dia.}^2 - \text{Stem dia.}^2) \times (\text{Gland bolt dia.}) \times (\text{Load factor})}{76.39 \times (\text{No. of bolts})}$$

Where: Bolt torque is in ft. lbs.

Bore, stem, and bolt diameters are in inches

Load factor is in psi

The load factor is determined by the following:

- For a 9000-EVSP Simplified set, a 9001 QUICKSET® or a Style #98 and GRAPH-LOCK® set:
LF = 1.5 system pressure or 3,800 psi (whichever is greater)
- When using any other Garlock packing:
LF = 1.5 system pressure or 5,500 psi (whichever is greater)

pH Values

The scientific shorthand for indicating the level of acidity or alkalinity of a substance is the pH value. The scale is

logarithmic, making lye, at 13, ten times as alkaline as ammonia at 12.

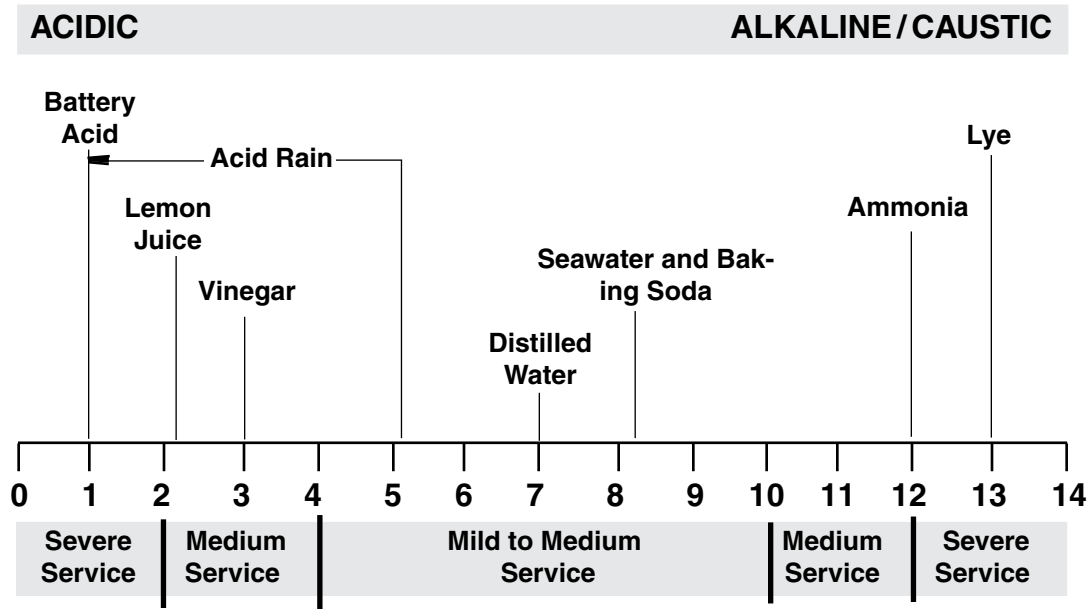

Common Oxidizers

Oxidizers act as a catalyst and cause hydrocarbons to combine with oxygen and cause breakdown of the fiber. Here is a partial listing of the most commonly used strong oxidizers. (A complete listing is available from Garlock Applications Engineering.)

- (a) Fluorine, used as an oxidizer or rocket fuel.
- (b) Sulfur Trioxide, used to make sulfuric acid.
- (c) Aqua Regia (nitric and hydrochloric acid), used to dissolve metals.
- (d) Sodium Peroxide, used in dyeing, paper and oxygen generation.
- (e) Oleum (fuming sulfuric), used in detergent and explosive manufacturing.
- (f) Perchloric Acid, used in the manufacturing of explosives, esters and medicine.
- (g) Sulfuric Acid, greater than 75% and over 250°F, the most widely-used industrial chemical.
- (h) Chloric Acid, greater than 10% and over 200°F, ignites organic materials on contact.
- (i) Ferric Chloride, greater than 50% and over 200°F, used for sewage treatment, photography, medicine, etching, feed additives and oxidizing disinfectant.
- (j) Nitric Acid, used in fertilizer, explosives, etching, medicine, dyeing and drugs.
- (k) Chlorous Acid, greater than 10% and over 200°F.
- (l) Iodine, greater than 5% and over 200°F, used in soaps, medicine, some lubricants, dyes and salt.
- (m) Hydrofluoric Acid, greater than 40% and over 200°F, used for pickling, purification, dissolving ores, cleaning castings, etching, cleaning stone and brick, and fermentation.
- (n) Sodium Hypochlorite, greater than 5%, used in textiles, water purification and bleaching pulp and paper.
- (o) Sodium Chlorate, greater than 5%, used as bleach for paper pulp, medicine and leather textiles.
- (p) Calcium Chlorate, greater than 5%, used in pyrotechnics and photography.

Ordering Information

Braided Packing

Sizes

Inches	mm	Inches	mm
1/8	3 x 3	—	12 x 12
—	4 x 4	1/2	12.7 x 12.7
3/16	5 x 5	9/16	14 x 14
—	6 x 6	5/8	16 x 16
1/4	6.5 x 6.5	11/16	18 x 18
5/16	8 x 8	3/4	19 x 19
3/8	9.5 x 9.5	13/16	20 x 20
—	10 x 10	7/8	22 x 22
7/16	11 x 11	1	25 x 25

Note: Additional cross-sections available on request.

Die-Formed Rings

Garlock can produce die-formed rings in more than 5,000 sizes. When placing your order, specify the I.D., the O.D., the ring/set height (and density if necessary).



RPM / FPM Conversion Table

		Shaft Rotary Speed (RPM)												
		100	300	500	1,000	1,500	1,750	2,000	2,500	3,000	3,600	4,000	4,500	5,000
Shaft Diameter (in)	0.500	13	39	65	131	196	229	262	327	393	471	524	589	654
	0.750	20	59	98	196	295	344	393	491	589	707	785	884	982
	1.000	26	79	131	262	393	458	524	654	785	942	1,047	1,178	1,309
	1.250	33	98	164	327	491	573	654	818	982	1,178	1,309	1,473	1,636
	1.500	39	118	196	393	589	687	785	982	1,178	1,414	1,571	1,767	1,963
	1.750	46	137	229	458	687	802	916	1,145	1,374	1,649	1,833	2,062	2,291
	2.000	52	157	262	524	785	916	1,047	1,309	1,571	1,885	2,094	2,356	2,618
	2.500	65	196	327	654	982	1,145	1,309	1,636	1,963	2,356	2,618	2,945	3,272
	3.000	79	236	393	785	1,178	1,374	1,571	1,963	2,356	2,827	3,142	3,534	3,927
	3.500	92	275	458	916	1,374	1,604	1,833	2,291	2,749	3,299	3,665	4,123	4,581
	4.000	105	314	524	1,047	1,571	1,833	2,094	2,618	3,142	3,770	4,189	4,712	5,236
	5.000	131	393	654	1,309	1,963	2,291	2,618	3,272	3,927	4,712	5,236	5,890	
	6.000	157	471	785	1,571	2,356	2,749	3,142	3,927	4,712	5,655			
7.000	183	550	916	1,833	2,749	3,207	3,665	4,581	5,498					
8.000	209	628	1,047	2,094	3,142	3,665	4,189	5,236						
9.000	236	707	1,178	2,356	3,534	4,123	4,712	5,890						
10.000	262	785	1,309	2,618	3,927	4,581	5,236							

Compression Packing Application Data Form

Customer _____

Submitted by _____

Date _____

Phone _____

Fax _____

Email _____

Service Conditions

Shaft speed _____ rpm (or) _____ fpm

Temperature _____ °F (or) _____ °C

Pressure _____ psi (or) _____ bar

Media (What is being sealed) _____ pH _____

Equipment

Specify pump, valve, mixer, etc. _____

Shaft dia. _____ Bore dia. _____ Box depth _____

General condition of equipment and environment _____

Packing

What is presently being used? _____

Any problems with this material? _____

Comments _____

More than just great products...

Beyond offering you the widest available range of products for packing and sealing, Garlock enhances the value of its products with technical services and comprehensive training programs:

- ISO 9001:2000 registration for Industrial Gasketing, Industrial Packing, KLOZURE® Oil Seals, Bearing Protectors, and Mechanical Seals, Expansion Joints, Hydraulic Components, and Industrial Rubber Products.
- A global network of stocking Authorized Garlock Distributors.
- Factory sales representatives and applications engineers available for problem solving when and where it is needed.
- Toll-free 800 telephone and fax numbers for immediate product information.
- In-plant surveys of equipment and processes, providing the customer with recommendations to identify and eliminate sealing and packing problems before they start.
- The most sophisticated and most comprehensive test facilities available.
- Technical field seminars on all Garlock products.
- Factory-sponsored product training programs, including hands-on seminars, to ensure that Garlock representatives and their distributor personnel are the best in the industry.
- Technical Bulletins to keep you up-to-date on product enhancements and changes.

Customers who specify Garlock fluid sealing products get, at no extra cost, the high quality support needed to run a profitable operation.

AUTHORIZED REPRESENTATIVE

WARNING:

Properties/applications shown throughout this brochure are typical. Your specific application should not be undertaken without independent study and evaluation for suitability. For specific application recommendations consult Garlock. Failure to select the proper sealing products could result in property damage and/or serious personal injury.

Performance data published in this brochure has been developed from field testing, customer field reports and/or in-house testing.

While the utmost care has been used in compiling this brochure, we assume no responsibility for errors. Specifications subject to change without notice. This edition cancels all previous issues. Subject to change without notice.

GARLOCK is a registered trademark for packings, seals, gaskets, and other products of Garlock.

© Garlock Inc 2008. All rights reserved worldwide.

Garlock
SEALING TECHNOLOGIES®

an EnPro Industries company

Garlock Sealing Technologies
1666 Division Street
Palmyra, New York 14522 USA
+1.315.597.4811
Toll Free 1.800.448.6688
Toll Free Fax: 1.800.543.0598
+1.315.597.3039

www.garlock.com

Other Garlock facilities are located in:

Columbia, SC, USA	Phone +1.803.783.1880	Fax +1.803.783.4279
Houston, TX, USA	Phone +1.281.840.4800	Fax +1.281.840.4756
Sydney, Australia	Phone +61.2.9793.2511	Fax +61.2.9793.2544
São Paulo, Brazil	Phone +55.11.4352.6161	Fax +55.11.4352.8181
Sherbrooke, Canada	Phone +1.819.563.8080	Fax +1.819.563.5620
W. Yorkshire, England	Phone +44.1422.313600	Fax +44.1422.313601
Saint-Étienne, France	Phone +33.4.7743.5100	Fax +33.4.7743.5151
Neuss, Germany	Phone +49.2131.3490	Fax +49.2131.349.222
Mexico City, Mexico	Phone +52.55.50.78.46.00	Fax +52.555.368.0418
Singapore	Phone +65.6285.9322	Fax +65.6284.5843
Shanghai, China	Phone +86.021.62789702	Fax +86.021.62787826
Dubai, UAE	Phone +971.4.8833652	Fax +971.4.8833682
Pune, India	Phone +91.20.3061.6608	Fax +91.20.3061.6699