

HIWIN®

Motion Control & Systems



Linear Guideways



Ballscrews



Positioning Systems

HIWIN Compact

Welcome to HIWIN

HIWIN offers a complete range of linear technology products. Our Compact Catalog provides an overview of our standard range, in stock and ready for delivery.

HIWIN Compact

Contents

1. Linear Guideways	6
1.1 Product Overview	6
1.2 Linear Guideway Series HG and QH	8
1.3 Linear Guideway Series EG and QE	24
1.4 Linear Guideway Series WE	38
1.5 Linear Guideway Series MG	50
1.6 Linear Guideway Series PM	63
1.7 Linear Guideway Series RG and QR	72
1.8 Accessories	86
2. Ballscrews	91
2.1 Product Overview	91
2.2 Rolled Ballscrews	94
2.3 Peeled Ballscrews	98
2.4 Accessories	106
3. Positioning Systems	122
3.1 KK Linear axes	122

Linear Guideways

Product Overview

1. Linear Guideways

A linear guideway facilitates linear movement using ball bearings. Thanks to the use of ball bearings between the rail and the block, it is possible for a linear guideway to achieve extremely precise linear movement. In comparison with a conventional guide rail, the friction coefficient is only one fiftieth. Due to the restricted guidance of the block on the rail the linear guideway can carry loads in vertical and horizontal directions.

1.1 Product Overview

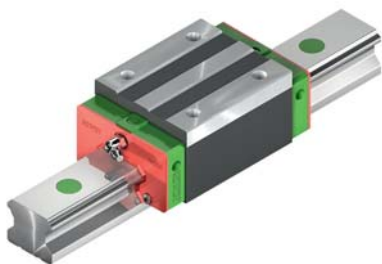

Linear Guideway Series HG and QH

Page 8

- 4-row recirculating ball bearing guide
- 45° contact angle of the ball tracks
- High load capacity in all installation positions
- High rigidity
- Block with SynchMotion™ technology (QH series)

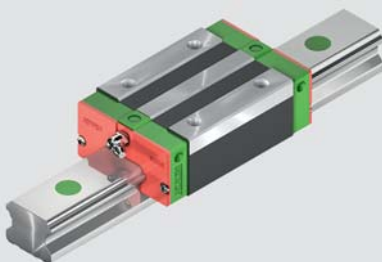

Linear Guideway Series EG and QE

Page 24

- 4-row recirculating ball bearing guide
- 45° contact angle of the ball tracks
- High load capacity in all installation positions
- Low assembly height
- Block with SynchMotion™ technology (QE series)



Linear Guideway Series WE

Page 38

- 4-row recirculating ball bearing guide
- 45° contact angle of the ball tracks
- High torque capacity
- Low assembly height

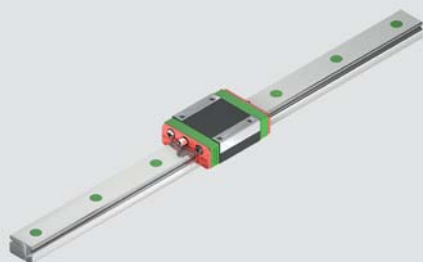

Linear Guideway Series MG

Page 50

- 2-row recirculating ball bearing guide
- 45° contact angle of the ball tracks
- Compact design
- Small and wide rails

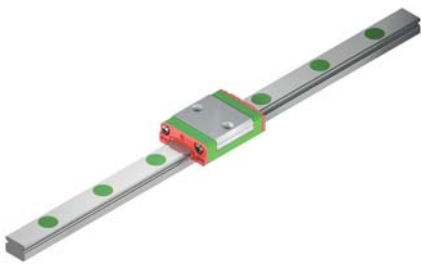

Linear Guideway Series PM

Page 63

- 2-row recirculating ball bearing guide
- 45° contact angle of the ball tracks
- Improved synchronization properties
- Small and wide rails
- Reduced weight

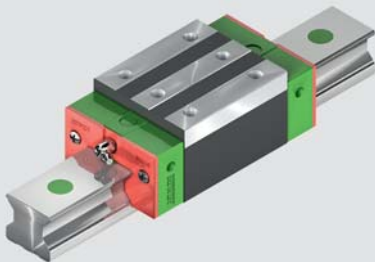

Linear Guideway Series RG and QR

Page 72

- 4-row recirculating roller bearing guide
- 45° contact angle of the ball tracks
- Recirculation roller guide
- Very high load capacity
- Very high rigidity
- Block with SynchMotion™ technology (QR series)

Accessories

Page 86

- Grease nipples
- Lubrication adapters
- Push-in fitting

Linear Guideways

HG/QH series

1.2 Linear Guideway Series HG and QH

1.2.1 Special characteristics of the linear guideway series HG and QH

The HIWIN linear guideways of the HG series with four ball tracks are designed for high loads and rigidities. Due to the 45° arrangement of the ball tracks the HG series can equally take loads from all directions. Low displacement forces and a high efficiency are further features of the HG series. The ball retainers prevent the balls from falling out when the block is pulled off the rail during assembly.

1.2.2 Structure of the HG/QH series

- 4-row recirculation ball bearing guide
- 45° contact angle of ball tracks
- Ball retainers prevent the balls from falling out when the block is removed
- Various sealing variants depending on the field of application
- 6 options for connecting grease nipple or lubrication adapter
- SynchMotion™ technology (QH series)

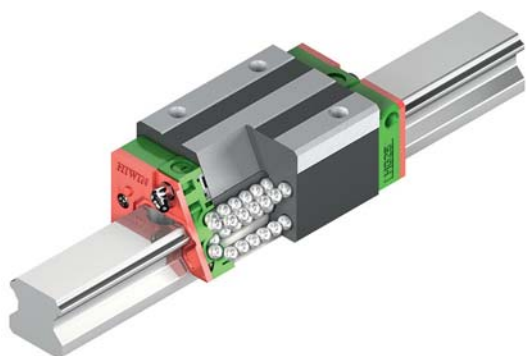

Fig. Structure of the HG series

1.2.3 Advantages

- Zero play
- Interchangeable
- High accuracy
- High loading capacity in all loading directions
- Low friction losses even with preload thanks to optimized ball tracks and 2-point contact

1.2.4 Article numbers of the HG/QH series

For HG/QH linear guideways, a distinction is made between interchangeable and non-interchangeable models. The dimensions of both models are the same. The main difference is that the block and rail in the interchangeable models can be freely interchanged. Block and rail can be ordered separately and fitted by the customer. Their accuracy extends to class P.

The series QH with SynchMotion™ technology owns all the technical advantages of the standard models of series HG. In addition, because of the controlled movement of the balls in a defined distance to each other, they are characterized by an improved synchronous performance, a higher maximum speed, longer lubrication intervals and a lower noise level. Since the mounting dimensions of the QH blocks are identical to those of the HG blocks, they are also mounted on the HGR standard rail and therefore are very easy to replace

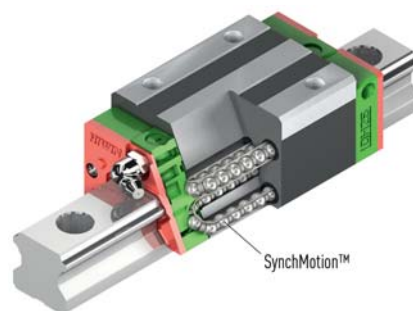

Fig. Structure of the QH series

Additional advantages of QH series

- Improved synchronous performance
- Optimized for higher travel speeds
- Extended lubrication intervals
- Less running noise

Given their stringent dimensional accuracy check, the interchangeable models are a good choice for customers who do not use rails in pairs on one axis. Non-interchangeable linear guideways are always supplied preassembled. The article numbers of the series include the dimensions, model, accuracy class, preload etc.

1.2.4.1 Non-interchangeable models (custom-assembled)

○ Article number of the fully assembled linear guideway

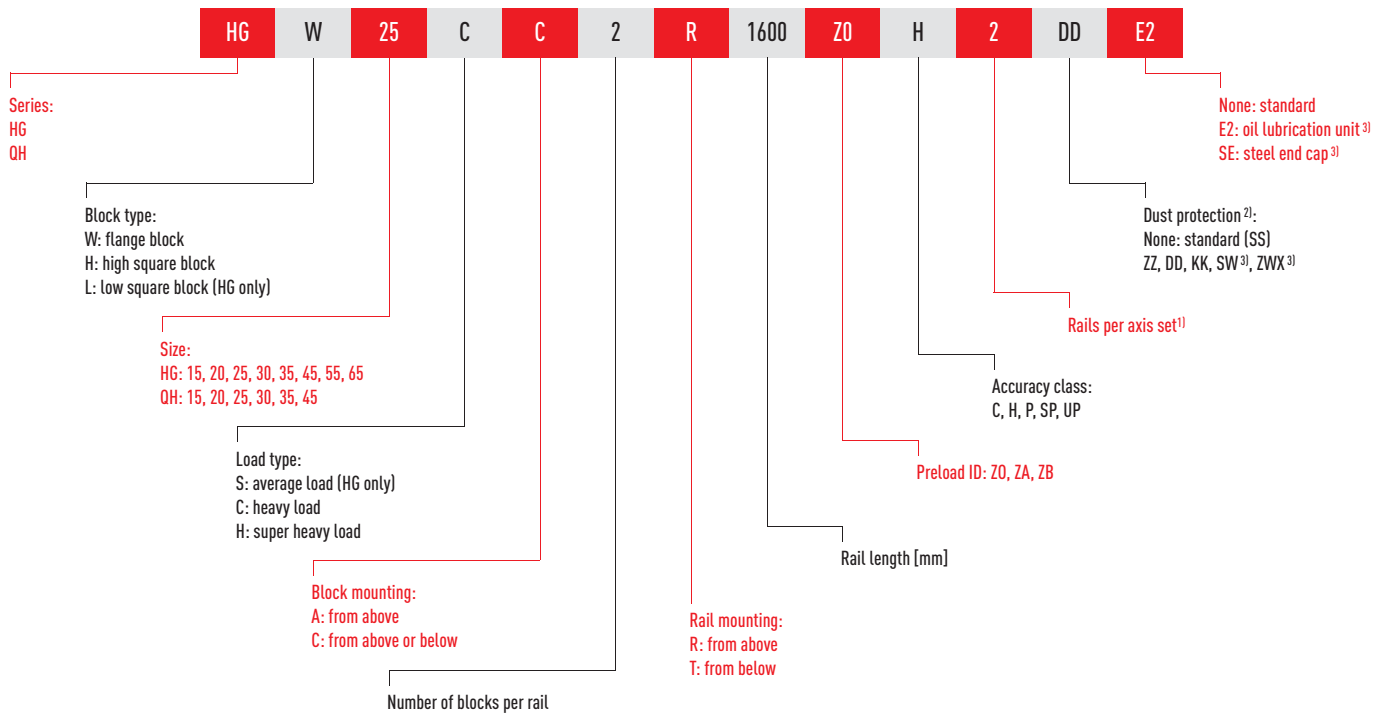

1.2.4.2 Interchangeable models

○ Article number of HG/QH block

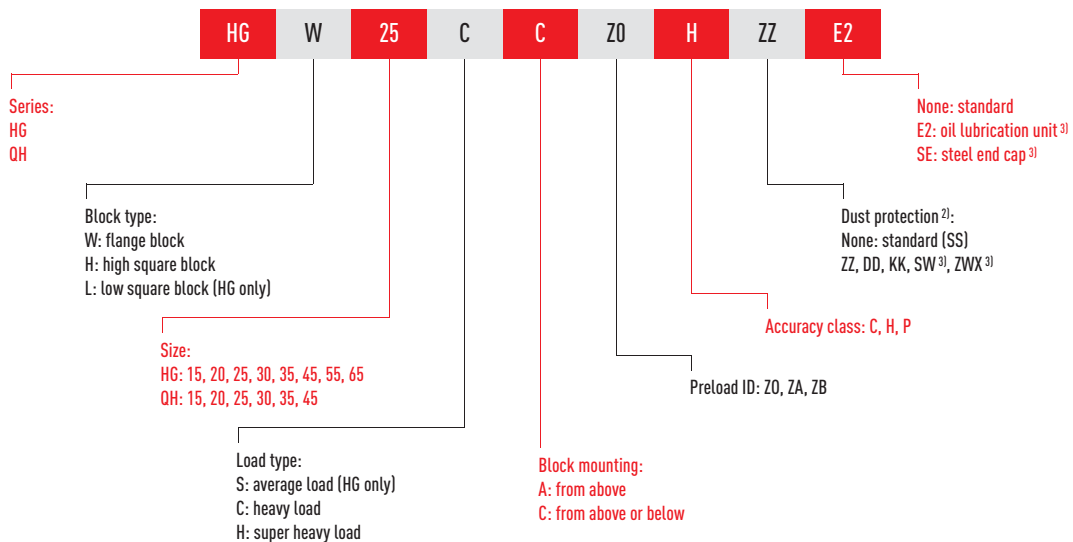

○ Article number of HG rail

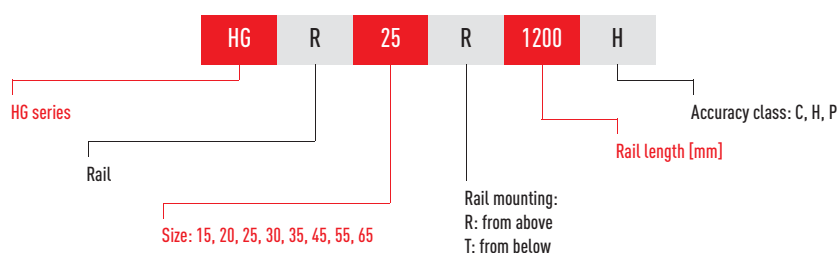

Note:
¹⁾ The figure 2 is also a quantity, i.e. one item of the above-mentioned article consists of a pair of rails. No number is specified for individual rails.
²⁾ You will find an overview of the individual sealing systems on page 89
³⁾ Only available for HG

Linear Guideways

HG/QH series

1.2.5 Block types

HIWIN provides square and flange blocks for its linear guideways. Given their low height and larger mounting surface, flange blocks are better suited to large loads.

Table 1.1 Block types

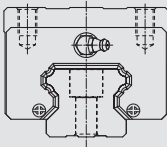
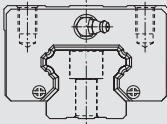
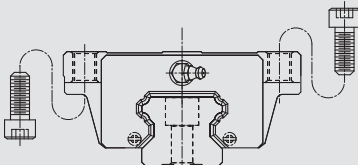
Type	Series/ size	Structure	Height [mm]	Rail length [mm]	Typical application
High square type	HGH-CA HGH-HA		28 – 90	100 – 4.000	<ul style="list-style-type: none"> ○ Machining centers ○ NC lathes ○ Grinding machines ○ Precision milling machines ○ High-performance cutting machines ○ Automation technology ○ Transport technology ○ Measuring technology ○ Machines and equipment requiring high positioning accuracy
Low square type	HGL-CA HGL-HA		24 – 70		
Flange type	HGW-CC HGW-HC		24 – 90		

1.2.6 Preload

1.2.6.1 Definition

Every rail type can be preloaded. Oversized balls are used for this purpose. Normally a linear guideway has negative clearance between track and balls to increase rigidity and precision. The curve shows that the rigidity doubles at higher preload. For rails below the nominal size of Z0, a preload of no more than ZA is recommended to avoid the life-time being shortened as a result of preload.

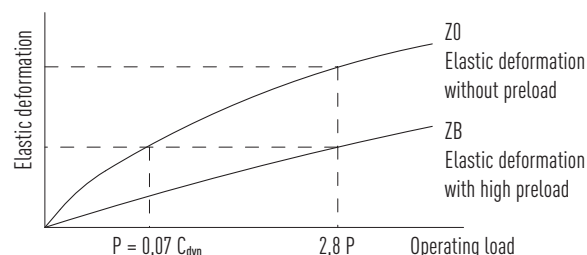

1.2.6.2 Preload ID

Table 1.2 Preload ID

ID	Preload		Application	Sample applications
Z0	Light preload	$0 - 0,02 C_{dyn}$	Constant load direction, little vibration, lower accuracy needed	Transport technology, automatic packaging machines, X-Y axis in industrial machines, welding machines
ZA	Medium preload	$0,05 - 0,07 C_{dyn}$	High accuracy needed	Machining centres, Z axes for industrial machines, eroding machines, NC lathes, precision X-Y tables, measuring technology
ZB	High preload	above $0,1 C_{dyn}$	High rigidity needed, vibration and impact	Machining centres, grinding machines, NC lathes, horizontal and vertical milling machines, Z axis of machine tools, high-performance cutting machines

Note:

Preload classes for interchangeable guides Z0 and ZA. For non-interchangeable guides Z0, ZA, ZB.

1.2.7 Load ratings and torques

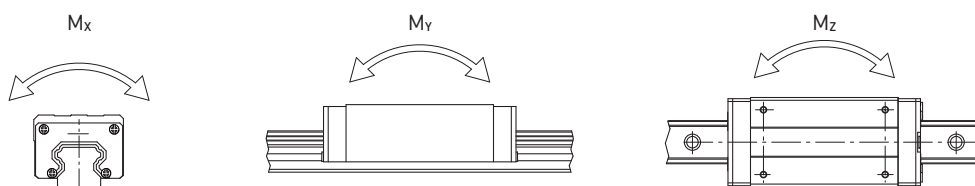

Table 1.3 Load ratings and torques for series HG/QH

Series/size	Dynamic load rating C_{dyn} [N]*	Static load rating C_0 [N]	Dynamic moment [Nm]			Static moment [Nm]		
			M_x	M_y	M_z	M_{0x}	M_{0y}	M_{0z}
HG_15C	11380	16970	76	67	67	120	100	100
QH_15C	13880	14360	90	84	84	100	80	80
HG_20S	12190	16110	99	61	61	130	80	80
HG_20C	17750	27760	178	126	126	270	200	200
QH_20C	23080	25630	231	171	171	260	190	190
HG_20H	21180	35900	208	203	203	350	350	350
QH_20H	27530	31670	268	230	230	310	270	270
HG_25C	26480	36490	301	240	240	420	330	330
QH_25C	31780	33680	361	294	294	390	310	310
HG_25H	32750	49440	374	379	379	560	570	570
QH_25H	39300	43620	451	410	410	500	450	450
HG_30C	38740	52190	494	396	396	660	530	530
QH_30C	46490	48170	588	491	491	600	500	500
HG_30H	47270	69160	600	630	630	880	920	920
QH_30H	56720	65090	722	623	623	830	890	890
HG_35C	49520	69160	832	577	577	1160	810	810
QH_35C	60520	63840	1019	720	720	1070	760	760
HG_35H	60210	91630	1011	918	918	1540	1400	1400
QH_35H	73590	86240	1233	1135	1135	1450	1330	1330
HG_45C	77570	102710	1497	1169	1169	1980	1550	1550
QH_45C	89210	94810	1723	1295	1295	1830	1380	1380
HG_45H	94540	136460	1825	1857	1857	2630	2680	2680
QH_45H	108720	128430	2097	2041	2041	2470	2410	2410
HG_55C	114440	148330	2843	2039	2039	3690	2640	2640
HG_55H	139350	196200	3464	3242	3242	4880	4570	4570
HG_65C	163630	215330	5049	3245	3245	6650	4270	4270
HG_65H	208360	303130	6449	5068	5068	9380	7380	7380

* Dynamic load rating for travel distance of 50 000 m

Linear Guideways

HG/QH series

1.2.8 Rigidity

Rigidity depends on preload. The adjacent formula can be used to determine deformation depending on rigidity.

$$\delta = \frac{P}{k}$$

δ : Deformation [μm]

P: Operating load [N]

k: Rigidity [N/ μm]

Table 1.4 Radial rigidity for series HG/QH

Load class	Series/ size	Preload		
		Z0	ZA	ZB
Average load	HG_20S	130	170	190
Heavy load	HG_15C	200	260	290
	QH_15C	180	230	260
	HG_20C	250	320	360
	QH_20C	230	290	320
	HG_25C	300	390	440
	QH_25C	270	350	400
	HG_30C	370	480	550
	QH_30C	330	430	500
	HG_35C	410	530	610
	QH_35C	370	480	550
	HG_45C	510	660	750
	QH_45C	460	590	680
	HG_55C	620	800	910
	HG_65C	760	980	1120
	Super heavy load	HG_20H	310	400
QH_20H		280	360	410
HG_25H		390	510	580
QH_25H		350	460	520
HG_30H		480	620	710
QH_30H		430	560	640
HG_35H		530	690	790
QH_35H		480	620	710
HG_45H		650	850	970
QH_45H		590	770	870
HG_55H		790	1030	1180
HG_65H	1030	1330	1520	

Unit: N/ μm

1.2.9 Dimensions of the HG/QH blocks

1.2.9.1 HGH/QHH

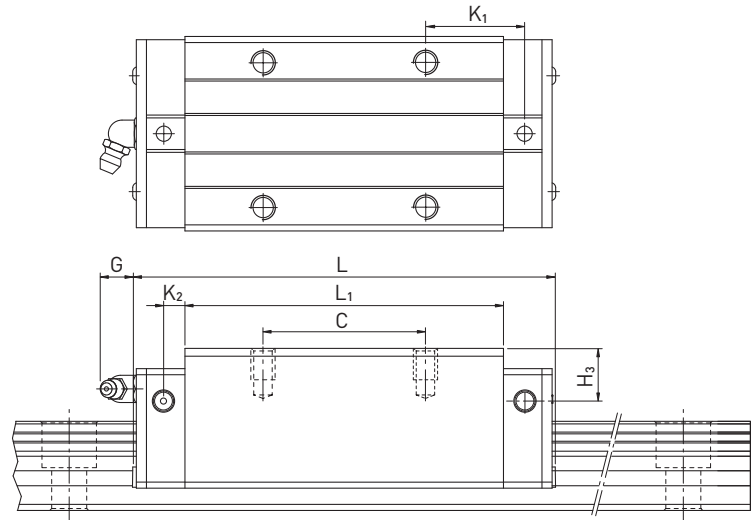
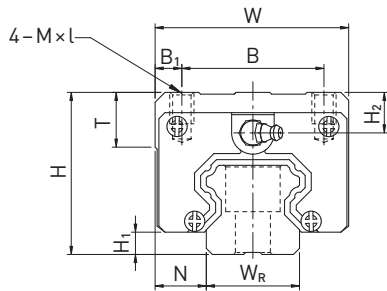

Table 1.5 Dimensions of the block

Series/ size	Installation dimensions [mm]			Dimensions of the block [mm]													Load Ratings [N]		Weight [kg]
	H	H ₁	N	W	B	B ₁	C	L ₁	L	K ₁	K ₂	G	M × l	T	H ₂	H ₃	C _{dyn}	C ₀	
HGH15CA	28	4,3	9,5	34	26,0	4,0	26	39,4	61,4	10,00	4,85	5,3	M4 × 5	6,0	7,95	7,7	11380	16970	0,18
QHH15CA	28	4,0	9,5	34	26,0	4,0	26	39,4	61,4	10,00	5,00	5,3	M4 × 5	6,0	7,95	8,2	13880	14360	0,18
HGH20CA	30	4,6	12,0	44	32,0	6,0	36	50,5	77,5	12,25	6,00	12,0	M5 × 6	8,0	6,00	6,0	17750	27760	0,30
HGH20HA							50	65,2	92,2	12,60							21180	35900	0,39
QHH20CA	30	4,6	12,0	44	32,0	6,0	36	50,5	76,7	11,75	6,00	12,0	M5 × 6	8,0	6,00	6,0	23080	25630	0,29
QHH20HA							50	65,2	91,4	12,10							27530	31670	0,38
HGH25CA	40	5,5	12,5	48	35,0	6,5	35	58,0	84,0	15,70	6,00	12,0	M6 × 8	8,0	10,00	9,0	26480	36490	0,51
HGH25HA							50	78,6	104,6	18,50							32750	49440	0,69
QHH25CA	40	5,5	12,5	48	35,0	6,5	35	58,0	83,4	15,70	6,00	12,0	M6 × 8	8,0	10,00	9,0	31780	33680	0,50
QHH25HA							50	78,6	104,0	18,50							39300	43620	0,68
HGH30CA	45	6,0	16,0	60	40,0	10,0	40	70,0	97,4	20,25	6,00	12,0	M8 × 10	8,5	9,50	13,8	38740	52190	0,88
HGH30HA							60	93,0	120,4	21,75							47270	69160	1,16
QHH30CA	45	6,0	16,0	60	40,0	10,0	40	70,0	97,4	19,50	6,25	12,0	M8 × 10	8,5	9,50	9,0	46490	48170	0,87
QHH30HA							60	93,0	120,4	21,75							56720	65090	1,15
HGH35CA	55	7,5	18,0	70	50,0	10,0	50	80,0	112,4	20,60	7,00	12,0	M8 × 12	10,2	16,00	19,6	49520	69160	1,45
HGH35HA							72	105,8	138,2	22,50							60210	91630	1,92
QHH35CA	55	7,5	18,0	70	50,0	10,0	50	80,0	113,6	19,00	7,50	12,0	M8 × 12	10,2	15,50	13,5	60520	63840	1,44
QHH35HA							72	105,8	139,4	20,90							73590	86240	1,90
HGH45CA	70	9,5	20,5	86	60,0	13,0	60	97,0	139,4	23,00	10,00	12,9	M10 × 17	16,0	18,50	30,5	77570	102710	2,73
HGH45HA							80	128,8	171,2	28,90							94540	136460	3,61
QHH45CA	70	9,2	20,5	86	60,0	13,0	60	97,0	139,4	23,00	10,00	12,9	M10 × 17	16,0	18,50	20,0	89210	94810	2,72
QHH45HA							80	128,8	171,2	29,09							108720	128430	3,59
HGH55CA	80	13,0	23,5	100	75,0	12,5	75	117,7	166,7	27,35	11,00	12,9	M12 × 18	17,5	22,00	29,0	114440	148330	4,17
HGH55HA							95	155,8	204,8	36,40							139350	196200	5,49
HGH65CA	90	15,0	31,5	126	76,0	25,0	70	144,2	200,2	43,10	14,00	12,9	M16 × 20	25,0	15,00	15,0	163630	215330	7,00
HGH65HA							120	203,6	259,6	47,80							208360	303130	9,82

For dimensions of the rail see page 16, for standard and optional lubrication adapters see page 86.

Linear Guideways

HG/QH series

1.2.9.2 HGL

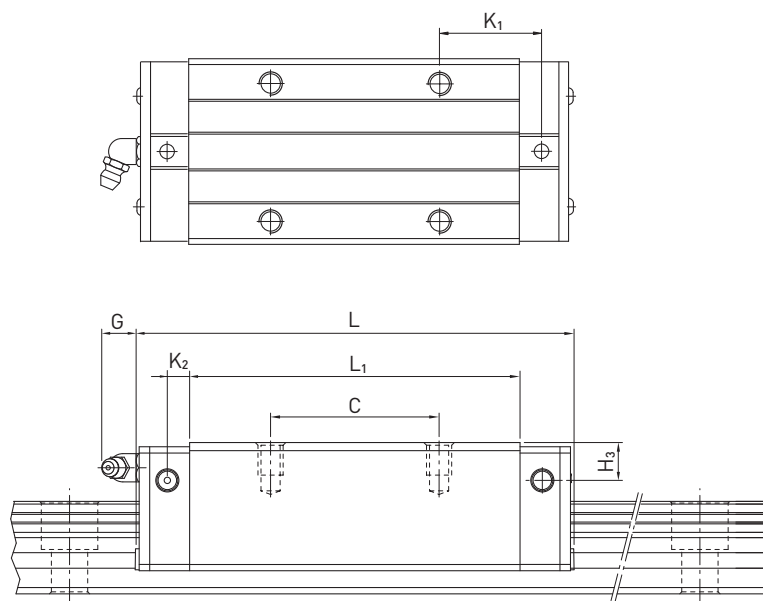
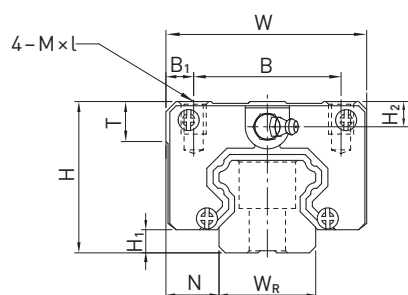

Table 1.6 Dimensions of the block

Series/ size	Installation dimensions [mm]			Dimensions of the block [mm]													Load Ratings [N]		Weight [kg]
	H	H ₁	N	W	B	B ₁	C	L ₁	L	K ₁	K ₂	G	M × l	T	H ₂	H ₃	C _{dyn}	C ₀	
HGL15CA	24	4,3	9,5	34	26,0	4,0	26	39,4	61,4	10,00	4,85	5,3	M4 × 4	6,0	3,95	3,7	11380	16970	0,14
HGL25CA	36	5,5	12,5	48	35,0	6,5	35	58,0	84,0	15,70	6,00	12,0	M6 × 6	8,0	6,00	5,0	26480	36490	0,42
HGL25HA							50	78,6	104,6	18,50							32750	49440	0,57
HGL30CA	42	6,0	16,0	60	40,0	10,0	40	70,0	97,4	20,25	6,00	12,0	M8 × 10	8,5	6,50	10,8	38740	52190	0,78
HGL30HA							60	93,0	120,4	21,75							47270	69160	1,03
HGL35CA	48	7,5	18,0	70	50,0	10,0	50	80,0	112,4	20,60	7,00	12,0	M8 × 12	10,2	9,00	12,6	49520	69160	1,14
HGL35HA							72	105,8	138,2	22,50							60210	91630	1,52
HGL45CA	60	9,5	20,5	86	60,0	13,0	60	97,0	139,4	23,00	10,00	12,9	M10 × 17	16,0	8,50	20,5	77570	102710	2,08
HGL45HA							80	128,8	171,2	28,90							94540	136460	2,75
HGL55CA	70	13,0	23,5	100	75,0	12,5	75	117,7	166,7	27,35	11,00	12,9	M12 × 18	17,5	12,00	19,0	114440	148330	3,25
HGL55HA							95	155,8	204,8	36,40							139350	196200	4,27

For dimensions of the rail see page 16, for standard and optional lubrication adapters see page 86.

1.2.9.3 HGW/QHW

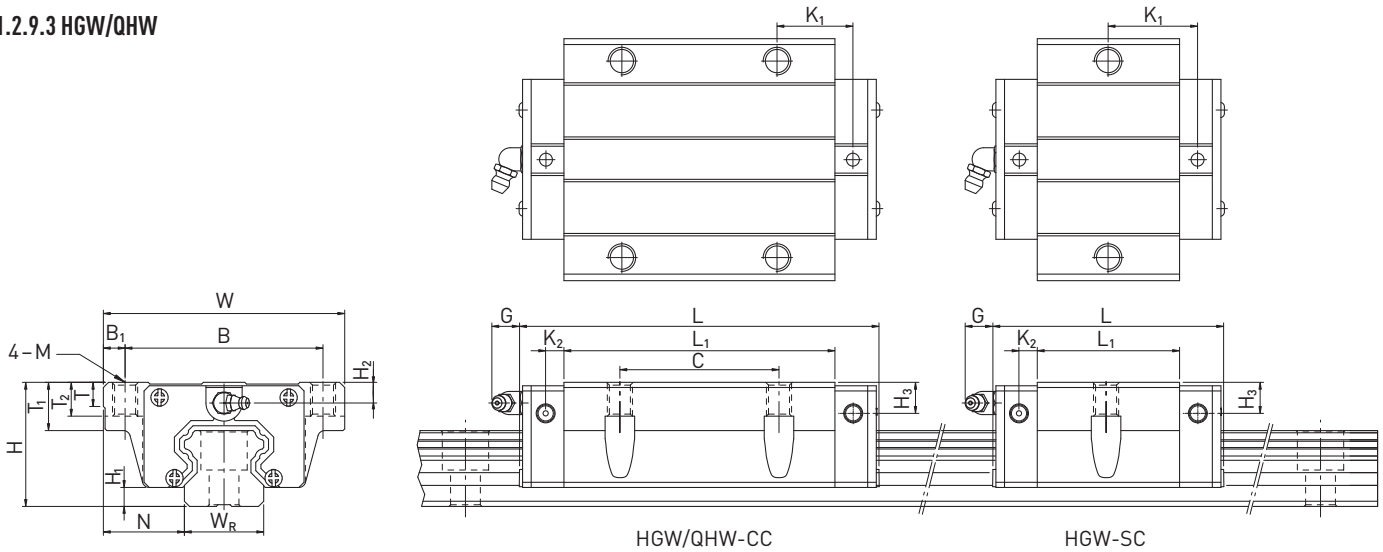

Table 1.7 Dimensions of the block

Series/ size	Installation dimensions [mm]			Dimensions of the block [mm]														Load Ratings [N]		Weight [kg]	
	H	H ₁	N	W	B	B ₁	C	L ₁	L	K ₁	K ₂	M	G	T	T ₁	T ₂	H ₂	H ₃	C _{dyn}		C ₀
HGW15CC	24	4,3	16,0	47	38,0	4,5	30	39,4	61,4	8,00	4,85	M5	5,3	6,0	8,9	7,0	3,95	3,7	11380	16970	0,17
QHW15CC	24	4,0	16,0	47	38,0	4,5	30	39,4	61,4	8,00	5,00	M5	5,3	6,0	8,9	7,0	3,95	4,2	13880	14360	0,17
HGW20SC	30	4,6	21,5	63	53,0	5,0	—	29,5	54,3	19,65	6,00	M6	12,0	8,0	10,0	9,5	6,00	6,0	12190	16110	0,28
HGW20CC							40	50,5	77,5	10,25									17750	27760	0,40
HGW20HC							65,2	92,2	17,60	21180									35900	0,52	
QHW20CC	30	4,6	21,5	63	53,0	5,0	40	50,5	76,7	9,75	6,00	M6	12,0	8,0	10,0	9,5	6,00	6,0	23080	25630	0,40
QHW20HC								65,2	91,4	17,10									27530	31670	0,52
HGW25CC	36	5,5	23,5	70	57,0	6,5	45	58,0	84,0	10,70	6,00	M8	12,0	8,0	14,0	10,0	6,00	5,0	26480	36490	0,59
HGW25HC								78,6	104,6	21,00									32750	49440	0,80
QHW25CC	36	5,5	23,5	70	57,0	6,5	45	58,0	83,4	10,70	6,00	M8	12,0	8,0	14,0	10,0	6,00	5,0	31780	33680	0,59
QHW25HC								78,6	104,0	21,00									39300	43620	0,80
HGW30CC	42	6,0	31,0	90	72,0	9,0	52	70,0	97,4	14,25	6,00	M10	12,0	8,5	16,0	10,0	6,50	10,8	38740	52190	1,09
HGW30HC								93,0	120,4	25,75									47270	69160	1,44
QHW30CC	42	6,0	31,0	90	72,0	9,0	52	70,0	97,4	13,50	6,25	M10	12,0	8,5	16,0	10,0	6,50	6,0	46490	48170	1,09
QHW30HC								93,0	120,4	25,75									56720	65090	1,44
HGW35CC	48	7,5	33,0	100	82,0	9,0	62	80,0	112,4	14,60	7,00	M10	12,0	10,1	18,0	13,0	9,00	12,6	49520	69160	1,56
HGW35HC								105,8	138,2	27,50									60210	91630	2,06
QHW35CC	48	7,5	33,0	100	82,0	9,0	62	80,0	113,6	13,00	7,50	M10	12,0	10,1	18,0	13,0	8,50	6,5	60520	63840	1,56
QHW35HC								105,8	139,4	25,90									73590	86240	2,06
HGW45CC	60	9,5	37,5	120	100,0	10,0	80	97,0	139,4	13,00	10,00	M12	12,9	15,1	22,0	15,0	8,50	20,5	77570	102710	2,79
HGW45HC								128,8	171,2	28,90									94540	136460	3,69
QHW45CC	60	9,2	37,5	120	100,0	10,0	80	97,0	139,4	13,00	10,00	M12	12,9	15,1	22,0	15,0	8,50	10,0	89210	94810	2,79
QHW45HC								128,8	171,2	28,90									108720	128430	3,69
HGW55CC	70	13,0	43,5	140	116,0	12,0	95	117,7	166,7	17,35	11,00	M14	12,9	17,5	26,5	17,0	12,00	19,0	114440	148330	4,52
HGW55HC								155,8	204,8	36,40									139350	196200	5,96
HGW65CC	90	15,0	53,5	170	142,0	14,0	110	144,2	200,2	23,10	14,00	M16	12,9	25,0	37,5	23,0	15,00	15,0	163630	215330	9,17
HGW65HC								203,6	259,6	52,80									208360	303130	12,89

For dimensions of the rail see page 16, for standard and optional lubrication adapters see page 86.

Linear Guideways

HG/QH series

1.2.10 Dimensions of the HG rail

The HG rails are used for both the HG and QH blocks.

1.2.10.1 Dimensions of HGR_R

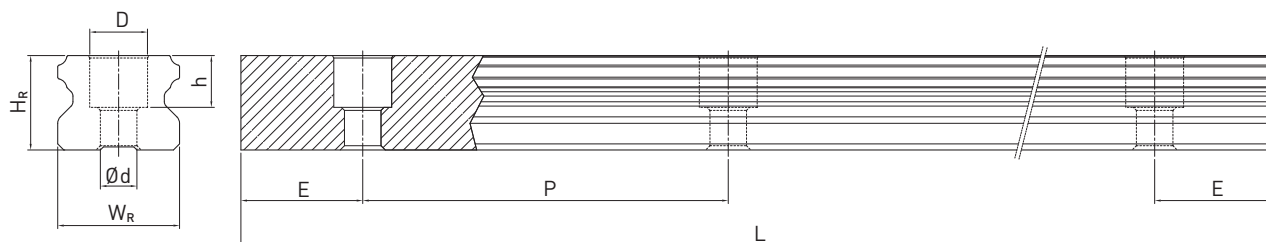

Table 1.8 Dimensions of rail HGR_R

Series/ size	Assembly screw for rail [mm]	Dimensions of rail [mm]						Max. length [mm]	Max. length E ₁ = E ₂	E _{1/2} min [mm]	E _{1/2} max [mm]	Weight [kg/m]
		W _R	H _R	D	h	d	P					
HGR15R	M4 × 16	15	15,0	7,5	5,3	4,5	60,0	4000	3900	6	54	1,45
HGR20R	M5 × 16	20	17,5	9,5	8,5	6,0	60,0	4000	3900	7	53	2,21
HGR25R	M6 × 20	23	22,0	11,0	9,0	7,0	60,0	4000	3900	8	52	3,21
HGR30R	M8 × 25	28	26,0	14,0	12,0	9,0	80,0	4000	3920	9	71	4,47
HGR35R	M8 × 25	34	29,0	14,0	12,0	9,0	80,0	4000	3920	9	71	6,30
HGR45R	M12 × 35	45	38,0	20,0	17,0	14,0	105,0	4000	3885	12	93	10,41
HGR55R	M14 × 45	53	44,0	23,0	20,0	16,0	120,0	4000	3840	14	106	15,08
HGR65R	M16 × 50	63	53,0	26,0	22,0	18,0	150,0	4000	3750	15	135	21,18

1.2.10.2 Dimensions of HGR_T (rail fastening from below)

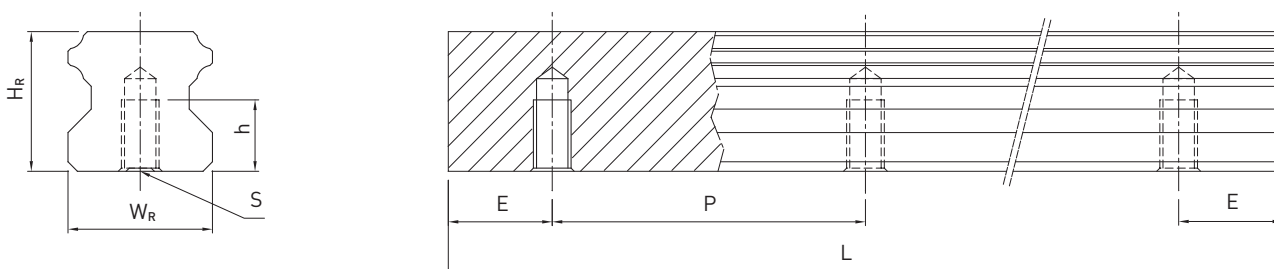

Table 1.9 Dimensions of rail HGR_T

Series/ size	Dimensions of rail [mm]					Max. length [mm]	Max. length E ₁ = E ₂	E _{1/2} min [mm]	E _{1/2} max [mm]	Weight [kg/m]
	W _R	H _R	S	h	P					
HGR15T	15	15,0	M5	8,0	60,0	4000	3900	6	54	1,48
HGR20T	20	17,5	M6	10,0	60,0	4000	3900	7	53	2,29
HGR25T	23	22,0	M6	12,0	60,0	4000	3900	8	52	3,35
HGR30T	28	26,0	M8	15,0	80,0	4000	3920	9	71	4,67
HGR35T	34	29,0	M8	17,0	80,0	4000	3920	9	71	6,51
HGR45T	45	38,0	M12	24,0	105,0	4000	3885	12	93	10,87
HGR55T	53	44,0	M14	24,0	120,0	4000	3840	14	106	15,67
HGR65T	63	53,0	M20	30,0	150,0	4000	3750	15	135	21,73

Note

1. The tolerance for E is +0.5 to -1 mm for standard rails and 0 to -0.3 mm for joints.
2. If the E_{1/2} dimensions are not indicated, the maximum possible number of mounting holes will be determined under consideration of E_{1/2} min.
3. The rails are shortened to the required length. If the E_{1/2} dimensions are not indicated, these will be carried out symmetrically.

1.2.10.3 Calculating the length of rails

HIWIN offers rails in customized lengths. To prevent the risk of the end of the rail becoming unstable, the value E must not exceed half of the distance between the mounting holes (P). At the same time, the value $E_{1/2}$ should be between $E_{1/2}$ min and $E_{1/2}$ max so that the mounting hole does not rupture.

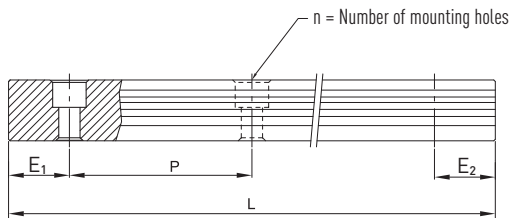

$$L = (n - 1) \cdot P + E_1 + E_2$$

L: Total length of the rail [mm]
 n: Number of mounting holes
 P: Distance between two mounting holes [mm]
 $E_{1/2}$: Distance from the middle of the last mounting hole to the end of the rail [mm]

1.2.10.4 Tightening torques for mounting bolts

Insufficient tightening of the mounting bolts strongly compromises the precision of the linear guideway; the following tightening torques are therefore recommended for the relevant screw sizes.

Table 1.11 Tightening torques of the mounting bolts according to ISO 4762-12.9

Series/size	Screw size	Torque [Nm]	Series/size	Screw size	Torque [Nm]
HG_15	M4 × 16	4	HG_35	M8 × 25	30
HG_20	M5 × 16	9	HG_35	M10	70
HG_25	M6 × 20	13	HG_45	M12 × 35	120
HG_30	M8 × 25	30	HG_55	M14 × 45	160
HG_30	M10	70	HG_65	M16 × 50	200

1.2.10.5 Cover caps for mounting holes of rails

The cover caps are used to keep the mounting holes free of chips and dirt. The standard plastic caps are provided with each rail. Optional cover caps must be ordered separately.



Table 1.12 Cover caps for mounting holes of rails

Rail	Screw	Article number			Ø D [mm]	Height H [mm]
		Plastic	Brass	Steel		
HGR15R	M4	C4	C4-M	—	7,5	1,1
HGR20R	M5	C5	C5-M	C5-ST	9,5	2,2
HGR25R	M6	C6	C6-M	C6-ST	11,0	2,5
HGR30R	M8	C8	C8-M	C8-ST	14,0	3,3
HGR35R	M8	C8	C8-M	C8-ST	14,0	3,3
HGR45R	M12	C12	C12-M	C12-ST	20,0	4,6
HGR55R	M14	C14	C14-M	C14-ST	23,0	5,5
HGR65R	M16	C16	C16-M	C16-ST	26,0	5,5

Linear Guideways

HG/QH series

1.2.11 Sealing systems

Various sealing systems are available for HIWIN blocks. You will find an overview on page 89. The table below shows the total length of the blocks with the different sealing systems. Sealing systems suitable for these sizes are available.

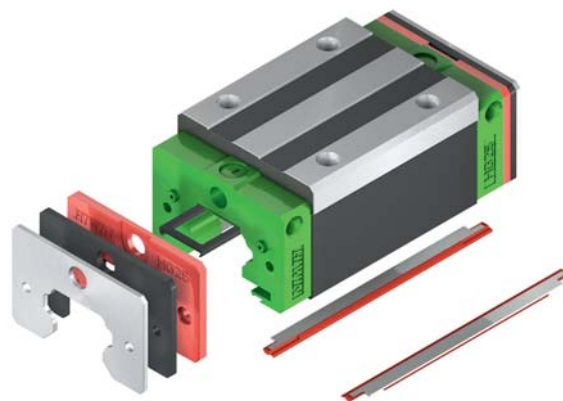

Table 1.13 Total length of blocks with different sealing systems

Series/ size	Total length L					
	SS	DD	ZZ	KK	SW	ZWX
HG_15C	61,4	68,0	69,0	75,6	63,2	—
QH_15C	61,4	68,0	68,4	75,0	—	—
HG_20S	56,5	59,5	57,5	62,5	57,5	61,3
HG_20C	77,5	82,5	82,5	87,5	78,5	82,3
QH_20C	76,7	81,7	81,9	86,9	—	—
HG_20H	92,2	97,5	97,2	102,2	93,2	97,0
QH_20H	91,4	96,4	96,6	101,6	—	—
HG_25C	84,0	89,0	89,0	94,0	85,0	91,8
QH_25C	83,4	88,4	89,4	94,4	—	—
HG_25H	104,6	109,6	109,6	114,6	105,6	112,4
QH_25H	104,4	109,0	110,0	115,0	—	—
HG_30C	97,4	104,8	105,4	112,8	99,0	105,8
QH_30C	97,4	104,8	104,8	112,2	—	—
HG_30H	120,4	127,8	128,4	135,8	122,0	128,8
QH_30H	120,4	127,8	127,8	135,2	—	—
HG_35C	112,4	119,8	120,4	127,8	115,2	122,4
QH_35C	113,6	118,6	119,0	124,0	—	—
HG_35H	138,2	145,6	146,2	153,6	141,0	148,2
QH_35H	139,4	144,4	144,8	149,8	—	—
HG_45C	139,4	149,4	150,0	160,0	140,0	144,8
QH_45C	139,4	146,6	147,2	154,4	—	—
HG_45H	171,2	181,2	181,8	191,8	171,8	176,6
QH_45H	171,2	178,4	179,0	186,2	—	—
HG_55C	166,7	177,1	177,1	187,5	163,7	172,9
HG_55H	204,8	215,2	215,2	225,5	201,8	211,0
HG_65C	200,2	209,2	208,2	217,2	196,2	203,4
HG_65H	259,6	268,6	267,6	276,6	255,6	262,8

Unit: mm

1.2.11.1 Designation of sealing sets

The sealing sets are always supplied along with the assembly material and include the parts needed in addition to the standard seal.

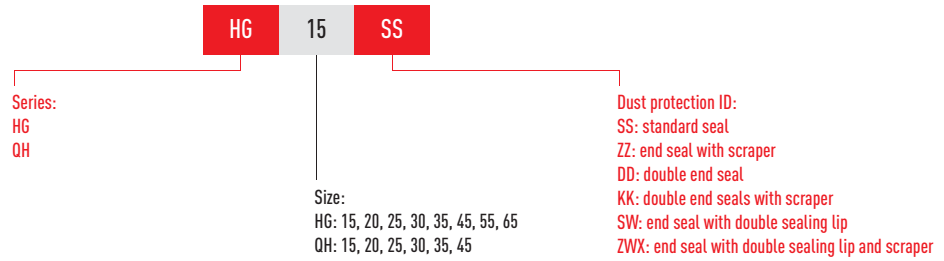

1.2.12 Friction

The table shows the maximum frictional resistance of the individual end seal. Depending on sealing setup (SS, DD, ZZ, KK), the value may have to be multiplied. The values indicated apply to blocks on uncoated rails. Higher friction forces occur on coated rails.

Table 1.15 Frictional resistance of single-lipped seals

Series/size	Friction force [N]	Series/size	Friction force [N]
HG/QH_15	1,2	HG_45	3,9
HG/QH_20	1,6	QH_45	5,3
HG/QH_25	2,0	HG_55	4,7
HG/QH_30	2,7	HG_65	5,8
HG/QH_35	3,1		

Linear Guideways

HG/QH series

1.2.13 Tolerances depending on accuracy class

The HG and QH series are available in five accuracy classes depending on parallelism between block and rail, height accuracy H and accuracy of width N. The choice of accuracy class is determined by the machine requirements.

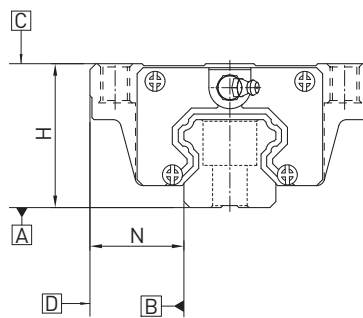

1.2.13.1 Parallelism

Parallelism of stop surfaces D and B of block and rail and parallelism of top of block C to mounting surface A of rail. Ideal linear guideway installation is required, as is a measurement in the centre of the block.

Table 1.16 Tolerance of parallelism between block and rail

Rail length [mm]	Accuracy class				
	C	H	P	SP	UP
- 100	12	7	3	2	2
100 - 200	14	9	4	2	2
200 - 300	15	10	5	3	2
300 - 500	17	12	6	3	2
500 - 700	20	13	7	4	2
700 - 900	22	15	8	5	3
900 - 1100	24	16	9	6	3
1100 - 1500	26	18	11	7	4
1500 - 1900	28	20	13	8	4
1900 - 2500	31	22	15	10	5
2500 - 3100	33	25	18	11	6
3100 - 3600	36	27	20	14	7
3600 - 4000	37	28	21	15	7

Unit: μm

1.2.13.2 Accuracy – height and width

Height tolerance H

Permissible absolute dimension variance of height H, measured between centre of screw-on surface C and underside of rail A, with block in any position on the rail.

Height variance of H

Permissible variance of height H between several blocks on a rail, measured in the same rail position.

Width tolerance N

Permissible absolute dimension variance of width N, measured between centre of screw-on surfaces D and B, with block in any position on the rail.

Width variance of N

Permissible variance of width N between several blocks on a rail, measured in the same rail position.

Table 1.17 Height and width tolerances of non-interchangeable types

Series/size	Accuracy class	Height tolerance of H	Width tolerance of N	Height variance of H	Width variance of N
HG_15, 20 QH_15, 20	Normal (C)	± 0,1	± 0,1	0,02	0,02
	High (H)	± 0,03	± 0,03	0,01	0,01
	Precision (P)	0 – 0,03	0 – 0,03	0,006	0,006
	Super precision (SP)	0 – 0,015	0 – 0,015	0,004	0,004
	Ultra precision (UP)	0 – 0,008	0 – 0,008	0,003	0,003
HG_25, 30, 35 QH_25, 30, 35	Normal (C)	± 0,1	± 0,1	0,02	0,03
	High (H)	± 0,04	± 0,04	0,015	0,015
	Precision (P)	0 – 0,04	0 – 0,04	0,007	0,007
	Super precision (SP)	0 – 0,02	0 – 0,02	0,005	0,005
	Ultra precision (UP)	0 – 0,01	0 – 0,01	0,003	0,003
HG_45, 55 QH_45	Normal (C)	± 0,1	± 0,1	0,03	0,03
	High (H)	± 0,05	± 0,05	0,015	0,02
	Precision (P)	0 – 0,05	0 – 0,05	0,007	0,01
	Super precision (SP)	0 – 0,03	0 – 0,03	0,005	0,007
	Ultra precision (UP)	0 – 0,02	0 – 0,02	0,003	0,005
HG_65	Normal (C)	± 0,1	± 0,1	0,03	0,03
	High (H)	± 0,07	± 0,07	0,02	0,025
	Precision (P)	0 – 0,07	0 – 0,07	0,01	0,015
	Super precision (SP)	0 – 0,05	0 – 0,05	0,007	0,01
	Ultra precision (UP)	0 – 0,03	0 – 0,03	0,005	0,007

Unit: mm

Linear Guideways

HG/QH series

Table 1.18 Height and width tolerances of interchangeable types

Series/size	Accuracy class	Height tolerance of H	Width tolerance of N	Height variance of H	Width variance of N
HG_15, 20 QH_15, 20	Normal (C)	$\pm 0,1$	$\pm 0,1$	0,02	0,02
	High (H)	$\pm 0,03$	$\pm 0,03$	0,01	0,01
	Precision (P)	$\pm 0,015$	$\pm 0,015$	0,006	0,006
HG_25, 30, 35 QH_25, 30, 35	Normal (C)	$\pm 0,1$	$\pm 0,1$	0,02	0,03
	High (H)	$\pm 0,04$	$\pm 0,04$	0,015	0,015
	Precision (P)	$\pm 0,02$	$\pm 0,02$	0,007	0,007
HG_45, 55 QH_45	Normal (C)	$\pm 0,1$	$\pm 0,1$	0,03	0,03
	High (H)	$\pm 0,05$	$\pm 0,05$	0,015	0,02
	Precision (P)	$\pm 0,025$	$\pm 0,025$	0,007	0,01
HG_65	Normal (C)	$\pm 0,1$	$\pm 0,1$	0,03	0,03
	High (H)	$\pm 0,07$	$\pm 0,07$	0,02	0,025
	Precision (P)	$\pm 0,035$	$\pm 0,035$	0,01	0,015

Unit: mm

1.2.14 Permissible mounting surface tolerances

Once the requirements relating to the accuracy of the mounting surfaces are met, the good accuracy, rigidity and lifetime of the HG and QH series linear guideways are achieved.

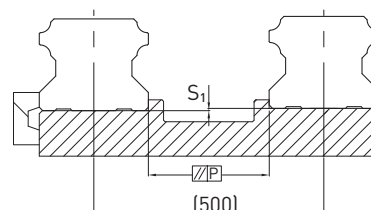

Parallelism of the reference surface (P)

Table 1.19 Maximum tolerance for parallelism (P)

Series/size	Preload class		
	Z0	ZA	ZB
HG/QH_15	25	18	—
HG/QH_20	25	20	18
HG/QH_25	30	22	20
HG/QH_30	40	30	27
HG/QH_35	50	35	30
HG/QH_45	60	40	35
HG_55	70	50	45
HG_65	80	60	55

Unit: μm

Table 1.20 Maximum tolerance for height of reference surface (S₁)

Series/size	Preload class		
	Z0	ZA	ZB
HG/QH_15	130	85	—
HG/QH_20	130	85	50
HG/QH_25	130	85	70
HG/QH_30	170	110	90
HG/QH_35	210	150	120
HG/QH_45	250	170	140
HG_55	300	210	170
HG_65	350	250	200

Unit: μm

1.2.15 Shoulder heights and fillets

Imprecise shoulder heights and fillets of mounting surfaces compromise precision and may lead to conflicts with the block or rail profiles. The following shoulder heights and edge profiles must be observed in order to avoid assembly problems.

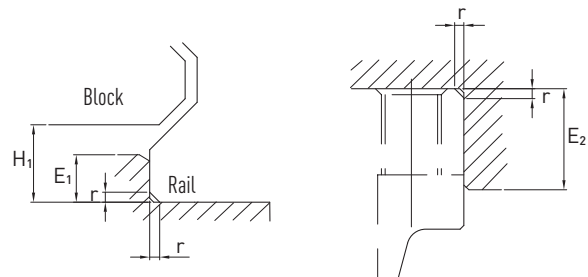

Table 1.21 Shoulder heights and fillets

Series/size	Max. edge radius r	Shoulder height of reference edge of rail E ₁	Shoulder height of reference edge of block E ₂	Clearance under block H ₁
HG_15	0,5	3,0	4,0	4,3
QH_15	0,5	3,0	4,0	4,0
HG/QH_20	0,5	3,5	5,0	4,6
HG/QH_25	1,0	5,0	5,0	5,5
HG/QH_30	1,0	5,0	5,0	6,0
HG/QH_35	1,0	6,0	6,0	7,5
HG/QH_45	1,0	8,0	8,0	9,5
HG_55	1,5	10,0	10,0	13,0
HG_65	1,5	10,0	10,0	15,0

Unit: mm

Linear Guideways

EG/QE series

1.3 Linear Guideway Series EG and QE

1.3.1 Special characteristics of the linear guideway series EG and QE

The design of the EG series offers a low profile, high load capacity, and high rigidity. It also features an equal load rating in all four directions and self-aligning capability to absorb installation-error, allowing for higher accuracies. Additionally, the lower assembly height and the shorter length makes the EG series more suitable for high-speed automation machines and applications where space is limited. The retainer is designed to hold the balls in the block even when it is removed from the rail.

1.3.2 Structure of the EG/QE series

- 4-row recirculation ball bearing guide
- 45° contact angle of ball tracks
- Ball retainers prevent the balls from falling out when the block is removed
- Various sealing variants depending on the field of application
- 6 options for connecting grease nipple or lubrication adapter
- SynchMotion™ technology (QE series)

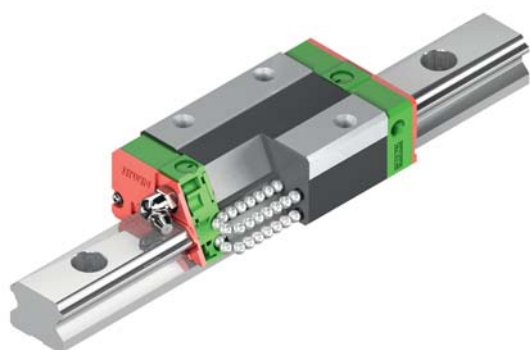

Fig. Structure of the EG series

1.3.3 Advantages

- Zero play
- Interchangeable
- High accuracy
- High loading capacity in all loading directions
- Low friction losses even with preload thanks to optimized ball tracks and 2-point contact

1.3.4 Article numbers of the EG/QE series

For EG/QE linear guideways, a distinction is made between interchangeable and non-interchangeable models. The dimensions of both models are the same. The main difference is that the block and rail in the interchangeable models can be freely interchanged. Block and rail can be ordered separately and fitted by the customer. Their accuracy extends to class P.

The series QE with SynchMotion™ technology owns all the technical advantages of the standard models of series EG. In addition, because of the controlled movement of the balls in a defined distance to each other, they are characterized by an improved synchronous performance, a higher maximum speed, longer lubrication intervals and a lower noise level. Since the mounting dimensions of the QE blocks are identical to those of the EG blocks, they are also mounted on the EGR standard rail and therefore are very easy to replace.

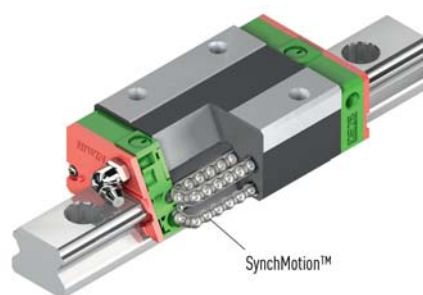

Fig. Structure of the QE series

Additional advantages of QE series

- Improved synchronous performance
- Optimized for higher travel speeds
- Extends lubrication intervals
- Less running noise

Given their stringent dimensional accuracy check, the interchangeable modules are a good choice for customers who do not use rails in pairs on one axis. Non-interchangeable linear guideways are always supplied preassembled. The article numbers of the series include the dimensions, model, accuracy class, preload etc.

1.3.4.1 Non-interchangeable models (custom-assembled)

○ Article number of the fully assembled linear guideway

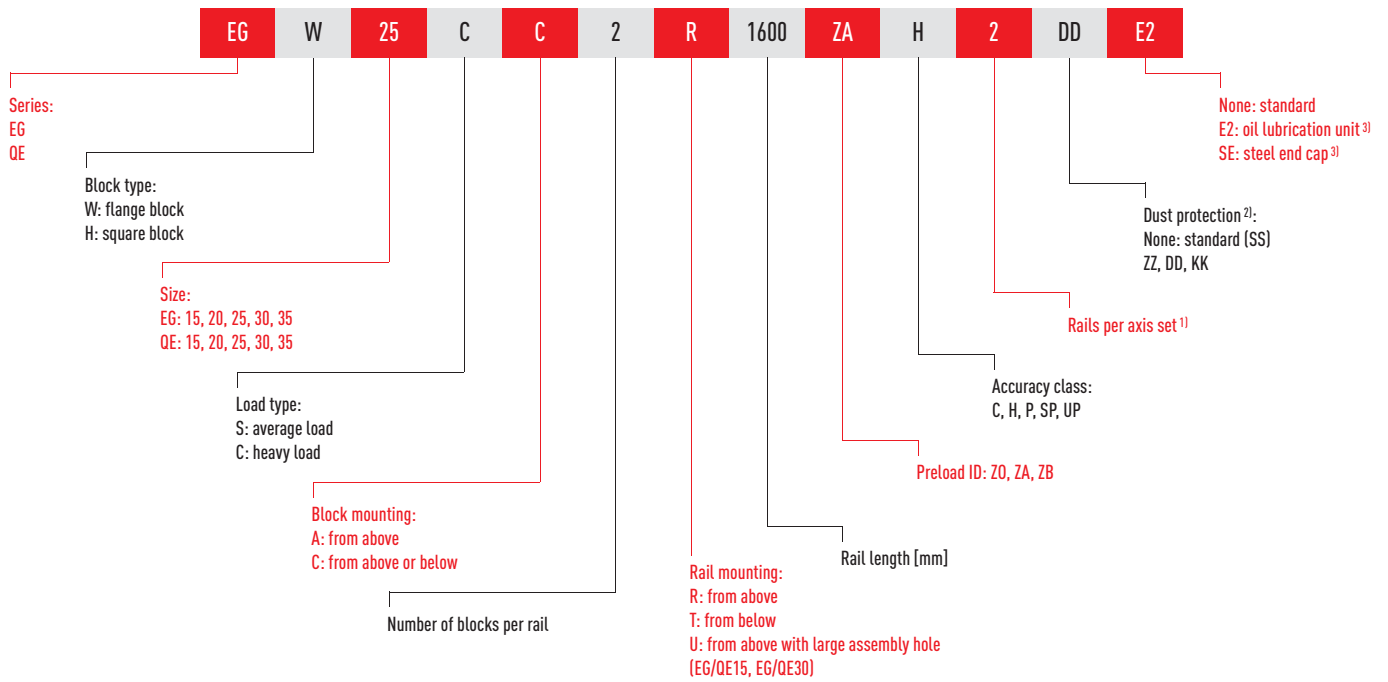

1.3.4.2 Interchangeable models

○ Article number of EG/QE block

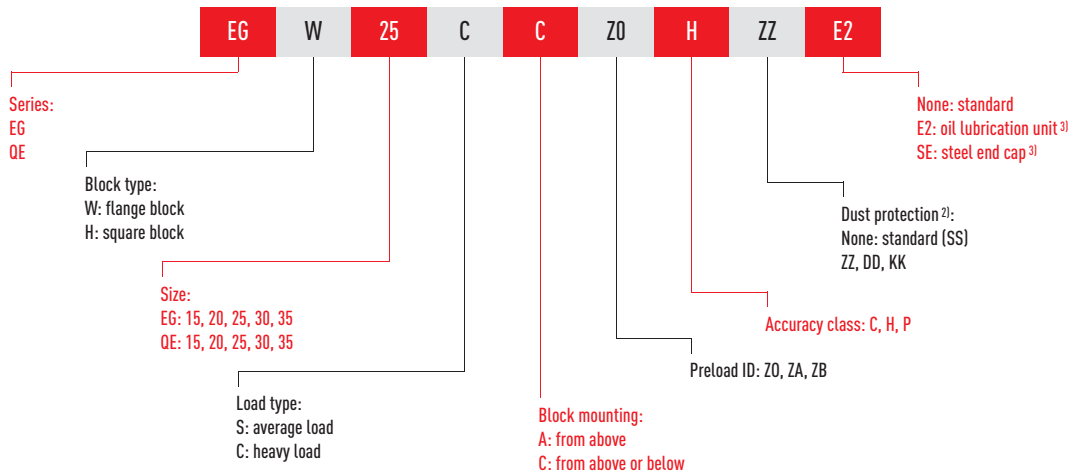

○ Article number of EG rail

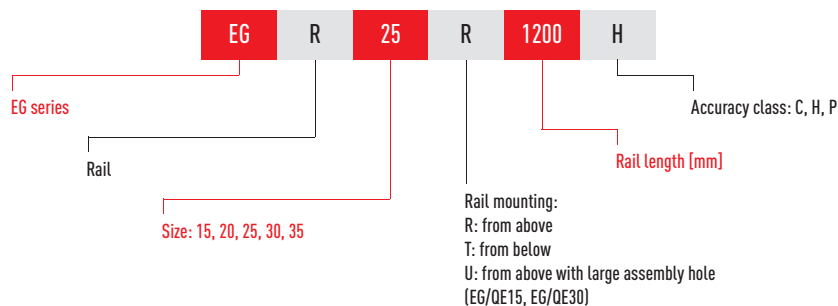

- Note:
- ¹⁾ The figure 2 is also a quantity, i.e. one item of the above-mentioned article consists of a pair of rails. No number is specified for individual rails.
 - ²⁾ You will find an overview of the individual sealing systems on page 89.
 - ³⁾ Only available for EG

Linear Guideways

EG/QE series

1.3.5 Block types

HIWIN provides square and flange blocks for its linear guideways. Given their low height and larger mounting surface, flange blocks are better suited to large loads.

Table 1.22 Block types

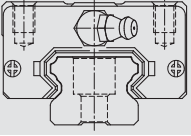
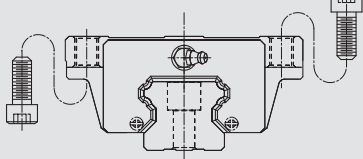
Type	Series/size	Structure	Height [mm]	Rail length [mm]	Typical application
Square type	EGH-SA EGH-CA		24 – 48	100 – 4.000	<ul style="list-style-type: none"> ○ Machining centers ○ NC lathes ○ Grinding machines ○ Precision milling machines ○ High-performance cutting machines ○ Automation technology ○ Transport technology ○ Measuring technology ○ Machines and equipment requiring high positioning accuracy
Flange type	EGW-SC EGW-CC				

1.3.6 Preload

1.3.6.1 Definition

Every rail type can be preloaded. Oversized balls are used for this purpose. Normally a linear guideway has negative clearance between track and balls to increase rigidity and precision. The curve shows that the rigidity doubles at higher preload. For rails below the nominal size of Z0, a preload of no more than ZA is recommended to avoid the lifetime being shortened as a result of preload.

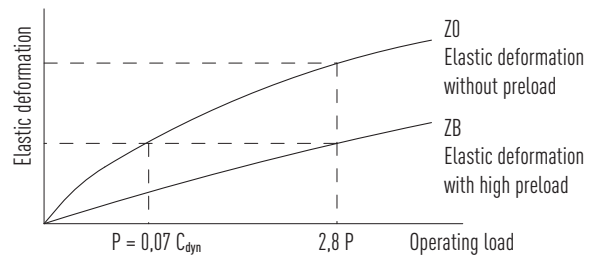

1.3.6.2 Preload ID

Table 1.23 Preload ID

ID	Preload		Application	Sample applications
Z0	Light preload	0 – 0,02 C _{dyn}	Constant load direction, low impact, low accuracy needed	Transport technology, automatic packaging machines, X-Y axis in industrial machines, welding machines
ZA	Medium preload	0,03 – 0,05 C _{dyn}	High accuracy needed	Machining centres, Z axes for industrial machines, eroding machines, NC lathes, precision X-Y tables, measuring technology
ZB	High preload	0,06 – 0,08 C _{dyn}	High rigidity needed, vibration and impact	Machining centres, grinding machines, NC lathes, horizontal and vertical milling machines, Z axis of machine tools, high-performance cutting machines

Note:

Preload classes for interchangeable guides Z0 and ZA. For non-interchangeable guides Z0, ZA, ZB.

1.3.7 Load ratings and torques

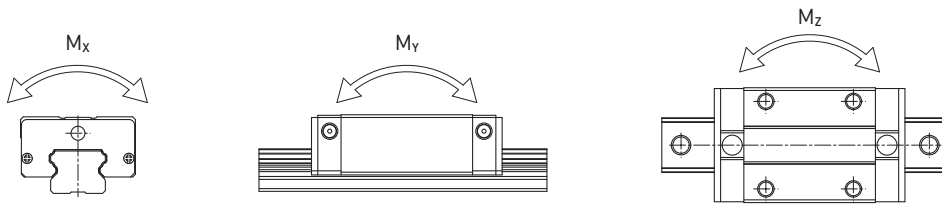

Table 1.24 Load ratings and torques for series EG/QE

Series/size	Dynamic load rating C_{dyn} [N]*	Static load rating C_0 [N]	Dynamic moment [Nm]			Static moment [Nm]		
			M_x	M_y	M_z	M_{0x}	M_{0y}	M_{0z}
EG_15S	5350	9400	45	22	22	80	40	40
QE_15S	8560	8790	68	29	29	70	30	30
EG_15C	7830	16190	62	48	48	130	100	100
QE_15C	12530	15280	98	73	73	120	90	90
EG_20S	7230	12740	73	34	34	130	60	60
QE_20S	11570	12180	123	47	47	130	50	50
EG_20C	10310	21130	107	78	78	220	160	160
QE_20C	16500	20210	171	122	122	210	150	150
EG_25S	11400	19500	134	70	70	230	120	120
QE_25S	18240	18900	212	96	96	220	100	100
EG_25C	16270	32400	190	160	160	380	320	320
QE_25C	26030	31490	305	239	239	370	290	290
EG_30S	16420	28100	233	122	122	400	210	210
QE_30S	26270	27820	377	169	169	400	180	180
EG_30C	23700	47460	339	274	274	680	550	550
QE_30C	37920	46630	544	414	414	670	510	510
EG_35S	22660	37380	339	187	187	560	310	310
QE_35S	36390	36430	609	330	330	610	330	330
EG_35C	33350	64840	504	354	354	980	690	690
QE_35C	51180	59280	863	648	648	1000	750	750

* Dynamic load rating for travel distance of 50 000 m

Linear Guideways

EG/QE series

1.3.8 Rigidity

Rigidity depends on preload. The adjacent formula can be used to determine deformation depending on rigidity.

$$\delta = \frac{P}{k}$$

δ: Deformation [μm]

P: Operating load [N]

k: Rigidity [N/μm]

Table 1.25 Radial rigidity for series EG/QE

Load class	Series/ size	Preload		
		Z0	ZA	ZB
Average load	EG_15S	105	126	141
	QE_15S	96	115	128
	EG_20S	126	151	168
	QE_20S	116	139	153
	EG_25S	156	187	209
	QE_25S	137	165	184
	EG_30S	184	221	246
	QE_30S	169	203	226
	EG_35S	221	265	295
	QE_35S	214	257	287
Heavy load	EG_15C	172	206	230
	QE_15C	157	187	209
	EG_20C	199	238	266
	QE_20C	183	219	245
	EG_25C	246	296	329
	QE_25C	219	263	293
	EG_30C	295	354	395
	QE_30C	271	326	363
	EG_35C	354	425	474
	QE_35C	333	399	445

Unit: N/μm

1.3.9 Dimensions of the EG/QE blocks

1.3.9.1 EGH/QEH

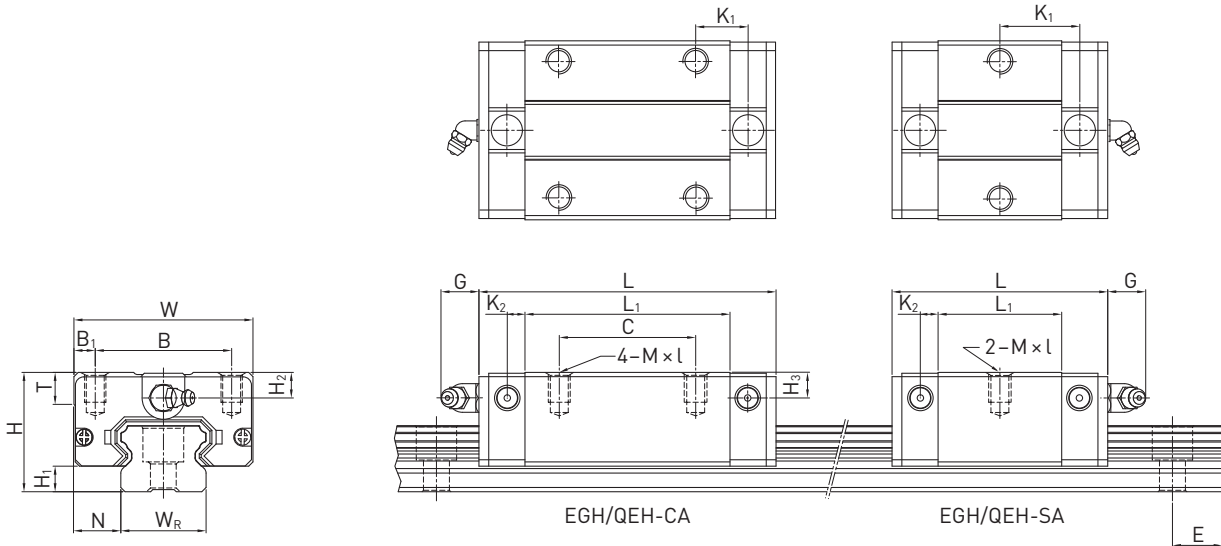

Table 1.26 Dimensions of the block

Series/ size	Installation dimensions [mm]			Dimensions of the block [mm]													Load Ratings [N]		Weight [kg]
	H	H ₁	N	W	B	B ₁	C	L ₁	L	K ₁	K ₂	G	M × l	T	H ₂	H ₃	C _{dyn}	C ₀	
EGH15SA	24	4,5	9,5	34	26,0	4,0	—	23,1	40,1	14,80	3,50	5,7	M4 × 6	6,0	5,50	6,0	5350	9400	0,09
EGH15CA							26	39,8	56,8	10,15							7830	16190	0,15
QEH15SA	24	4,0	9,5	34	26,0	4,0	—	23,1	40,1	14,80	3,50	5,7	M4 × 6	6,0	5,50	6,0	8560	8790	0,09
QEH15CA							26	39,8	56,8	10,15							12530	15280	0,15
EGH20SA	28	6,0	11,0	42	32,0	5,0	—	29,0	50,0	18,75	4,15	12,0	M5 × 7	7,5	6,00	6,0	7230	12740	0,15
EGH20CA							32	48,1	69,1	12,30							10310	21130	0,24
QEH20SA	28	6,0	11,0	42	32,0	5,0	—	29,0	50,0	18,75	4,15	12,0	M5 × 7	7,5	6,00	6,5	11570	12180	0,15
QEH20CA							32	48,1	69,1	12,30							16500	20210	0,23
EGH25SA	33	7,0	12,5	48	35,0	6,5	—	35,5	59,1	21,90	4,55	12,0	M6 × 9	8,0	8,00	8,0	11400	19500	0,25
EGH25CA							35	59,0	82,6	16,15							16270	32400	0,41
QEH25SA	33	6,2	12,5	48	35,0	6,5	—	35,5	60,1	21,90	5,00	12,0	M6 × 9	8,0	8,00	8,0	18240	18900	0,24
QEH25CA							35	59,0	83,6	16,15							26030	31490	0,40
EGH30SA	42	10,0	16,0	60	40,0	10,0	—	41,5	69,5	26,75	6,00	12,0	M8 × 12	9,0	8,00	9,0	16420	28100	0,45
EGH30CA							40	70,1	98,1	21,05							23700	47460	0,76
QEH30SA	42	10,0	16,0	60	40,0	10,0	—	41,5	67,5	25,75	6,00	12,0	M8 × 12	9,0	8,00	9,0	26270	27820	0,44
QEH30CA							40	70,1	96,1	20,05							37920	46630	0,75
EGH35SA	48	11,0	18,0	70	50,0	10,0	—	45,0	75,0	28,50	7,00	12,0	M8 × 12	10,0	8,50	8,5	22660	37380	0,74
EGH35CA							50	78,0	108,0	20,00							33350	64840	1,10
QEH35SA	48	11,0	18,0	70	50,0	10,0	—	51,0	76,0	30,30	6,25	12,0	M8 × 12	10,0	8,50	8,5	36390	36430	0,58
QEH35CA							50	83,0	108,0	21,30							51180	59280	0,90

For dimensions of rail, see page 31, for standard and optional lubrication adapter, see page 86.

Linear Guideways

EG/QE series

1.3.9.2 EGW/QEW

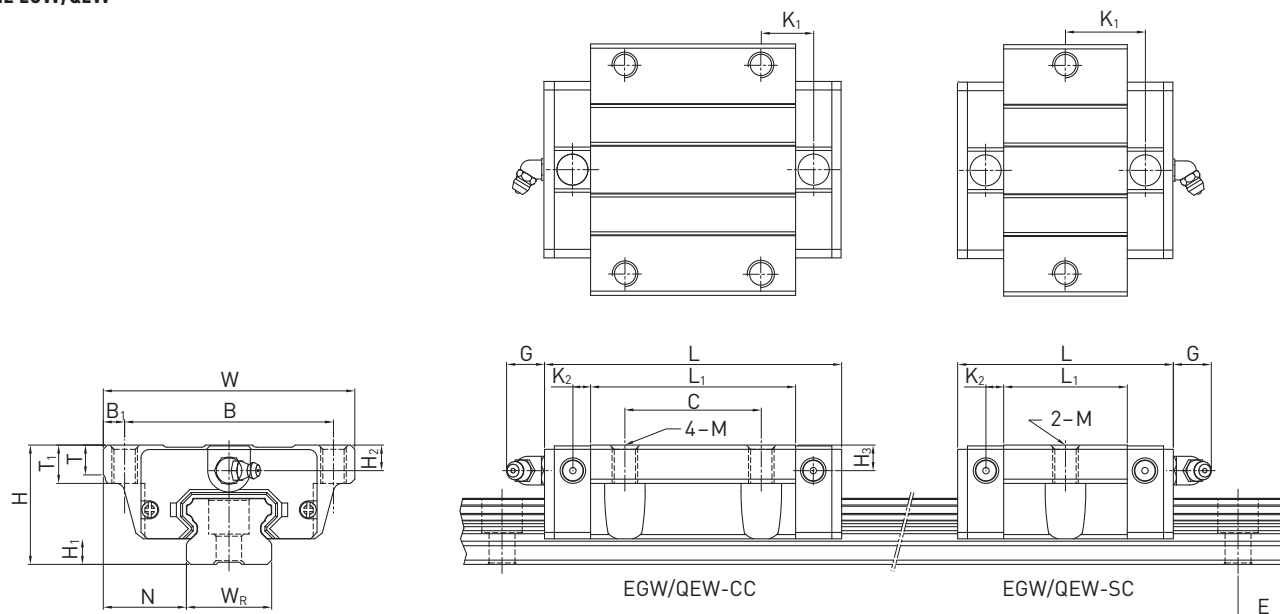

Table 1.27 Dimensions of the block

Series/ size	Installation dimensions [mm]			Dimensions of the block [mm]														Load Ratings [N]		Weight [kg]
	H	H ₁	N	W	B	B ₁	C	L ₁	L	K ₁	K ₂	G	M	T	T ₁	H ₂	H ₃	C _{dyn}	C ₀	
EGW15SC	24	4,5	18,5	52	41,0	5,5	—	23,1	40,1	14,80	3,50	5,7	M5	5,0	7,0	5,50	6,0	5350	9400	0,12
EGW15CC							26	39,8	56,8	10,15								7830	16190	0,21
QEW15SC	24	4,0	18,5	52	41,0	5,5	—	23,1	40,1	14,80	3,50	5,7	M5	5,0	0,0	5,50	6,0	8560	8790	0,12
QEW15CC							26	39,8	56,8	10,15								12530	15280	0,21
EGW20SC	28	6,0	19,5	59	49,0	5,0	—	29,0	50,0	18,75	4,15	12,0	M6	7,0	9,0	6,00	6,0	7230	12740	0,19
EGW20CC							32	48,1	69,1	12,30								10310	21130	0,32
QEW20SC	28	6,0	19,5	59	49,0	5,0	—	29,0	50,0	18,75	4,15	12,0	M6	7,0	0,0	6,00	6,5	11570	12180	0,19
QEW20CC							32	48,1	69,1	12,30								16500	20210	0,31
EGW25SC	33	7,0	25,0	73	60,0	6,5	—	35,5	59,1	21,90	4,55	12,0	M8	7,5	10,0	8,00	8,0	11400	19500	0,35
EGW25CC							35	59,0	82,6	16,15								16270	32400	0,59
QEW25SC	33	6,2	25,0	73	60,0	6,5	—	35,5	60,1	21,90	5,00	12,0	M8	7,5	0,0	8,00	8,0	18240	18900	0,34
QEW25CC							35	59,0	83,6	16,15								26030	31490	0,58
EGW30SC	42	10,0	31,0	90	72,0	9,0	—	41,5	69,5	26,75	6,00	12,0	M10	7,0	10,0	8,00	9,0	16420	28100	0,62
EGW30CC							40	70,1	98,1	21,05								23700	47460	1,04
QEW30SC	42	10,0	31,0	90	72,0	9,0	—	41,5	67,5	25,75	6,00	12,0	M10	7,0	0,0	8,00	9,0	26270	27820	0,61
QEW30CC							40	70,1	96,1	20,05								37920	46630	1,03
EGW35SC	48	11,0	33,0	100	82,0	9,0	—	45,0	75,0	28,50	7,00	12,0	M10	10,0	13,0	8,50	8,5	22660	37380	0,91
EGW35CC							50	78,0	108,0	20,00								33350	64840	1,40
QEW35SC	48	11,0	33,0	100	82,0	9,0	—	51,0	76,0	30,30	6,25	12,0	M10	10,0	13,0	8,50	8,5	36390	36430	0,77
QEW35CC							50	83,0	108,0	21,30								51180	59280	1,19

For dimensions of rail, see page 31, for standard and optional lubrication adapter, see page 86.

1.3.10 Dimensions of the EG rail

The EG rails are used for both the EG and QE blocks.

1.3.10.1 Dimensions of EGR_R

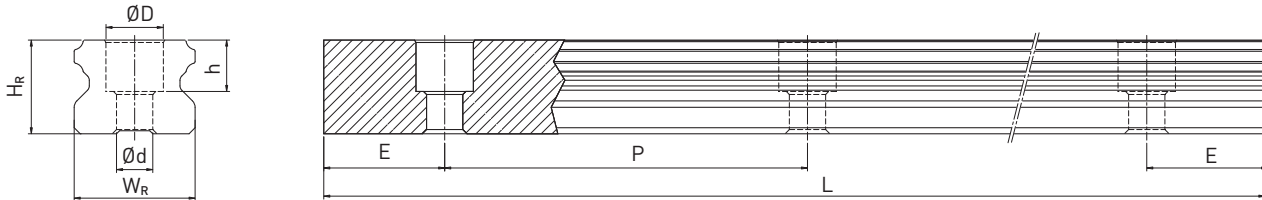

Table 1.28 Dimensions of rail EGR_R

Series/ size	Assembly screw for rail [mm]	Dimensions of rail [mm]						Max. length [mm]	Max. length $E_1 = E_2$	$E_{1/2}$ min [mm]	$E_{1/2}$ max [mm]	Weight [kg/m]
		W_R	H_R	D	h	d	P					
EGR15R	M3 × 16	15	12,5	6,0	4,5	3,5	60,0	4000	3900	6	54	1,25
EGR20R	M5 × 16	20	15,5	9,5	8,5	6,0	60,0	4000	3900	7	53	2,08
EGR25R	M6 × 20	23	18,0	11,0	9,0	7,0	60,0	4000	3900	8	52	2,67
EGR30R	M6 × 25	28	23,0	11,0	9,0	7,0	80,0	4000	3920	9	71	4,35
EGR35R	M8 × 25	34	27,5	14,0	12,0	9,0	80,0	4000	3920	9	71	6,14

1.3.10.2 Dimensions of EGR_U (large mounting holes)

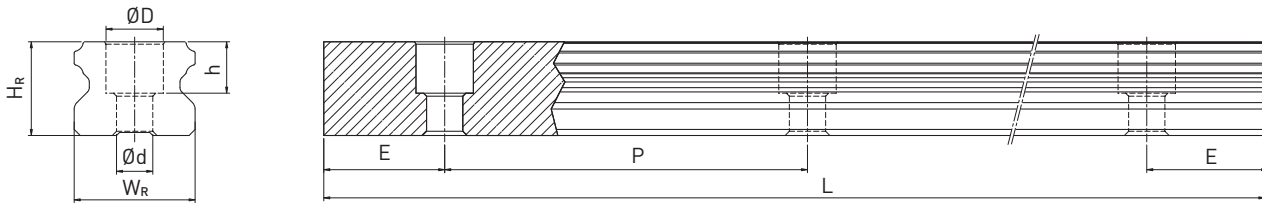

Table 1.29 Dimensions of rail EGR_U

Series/ size	Assembly screw for rail [mm]	Dimensions of rail [mm]						Max. length [mm]	Max. length $E_1 = E_2$	$E_{1/2}$ min [mm]	$E_{1/2}$ max [mm]	Weight [kg/m]
		W_R	H_R	D	h	d	P					
EGR15U	M4 × 16	15	12,5	7,5	5,3	4,5	60,0	4000	3900	6	54	1,23
EGR30U	M8 × 25	28	23,0	14,0	12,0	9,0	80,0	4000	3920	9	71	4,23

- Note:
1. The tolerance for E is +0.5 to -1 mm for standard rails and 0 to -0.3 mm for joints.
 2. If the $E_{1/2}$ dimensions are not indicated, the maximum possible number of mounting holes will be determined under consideration of $E_{1/2}$ min.
 3. The rails are shortened to the required length. If the $E_{1/2}$ dimensions are not indicated, these will be carried out symmetrically.

Linear Guideways

EG/QE series

1.3.10.3 Dimensions of EGR_T (rail mounting from below)

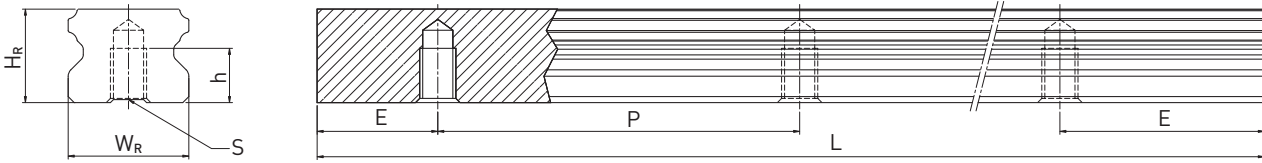

Table 1.30 Dimensions of rail EGR_T

Series/ size	Dimensions of rail [mm]					Max. length [mm]	Max. length $E_1 = E_2$	$E_{1/2}$ min [mm]	$E_{1/2}$ max [mm]	Weight [kg/m]
	W_R	H_R	S	h	P					
EGR15T	15	12,5	M5	7,0	60,0	4000	3900	6	54	1,26
EGR20T	20	15,5	M6	9,0	60,0	4000	3900	7	53	2,15
EGR25T	23	18,0	M6	10,0	60,0	4000	3900	8	52	2,79
EGR30T	28	23,0	M8	14,0	80,0	4000	3920	9	71	4,42
EGR35T	34	27,5	M8	17,0	80,0	4000	3920	9	71	6,34

Note

1. The tolerance for E is +0.5 to -1 mm for standard rails and 0 to -0.3 mm for joints.
2. If the $E_{1/2}$ dimensions are not indicated, the maximum possible number of mounting holes will be determined under consideration of $E_{1/2}$ min.
3. The rails are shortened to the required length. If the $E_{1/2}$ dimensions are not indicated, these will be carried out symmetrically.

1.3.10.4 Calculating the length of rails

HIWIN offers rails in customised lengths. To prevent the risk of the end of the rail becoming unstable, the value E must not exceed half of the distance between the mounting holes (P). At the same time, the value $E_{1/2}$ should be between $E_{1/2}$ min and $E_{1/2}$ max so that the mounting hole does not rupture.

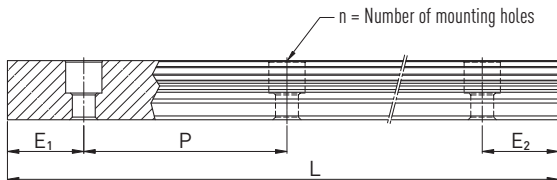

$$L = (n - 1) \cdot P + E_1 + E_2$$

- L: Total length of the rail [mm]
n: Number of mounting holes
P: Distance between two mounting holes [mm]
 $E_{1/2}$: Distance from the middle of the last mounting hole to the end of the rail [mm]

1.3.10.5 Tightening torques for mounting bolts

Insufficient tightening of the mounting bolts strongly compromises the precision of the linear guideway; the following tightening torques are therefore recommended for the relevant screw sizes.

Table 1.32 Tightening torques of the mounting bolts according to ISO 4762-12.9

Series/size	Screw size	Torque [Nm]	Series/size	Screw size	Torque [Nm]
EG_15	M3 × 16	2	EG_30	M6 × 25	13
EG_15U	M4 × 16	4	EG_30U	M8 × 25	30
EG_20	M5 × 16	9	EG_35	M8 × 25	30
EG_25	M6 × 20	13			

1.3.10.6 Cover caps for mounting holes of rails

The cover caps are used to keep the mounting holes free of chips and dirt. The standard plastic caps are provided with each rail. Optional cover caps must be ordered separately.

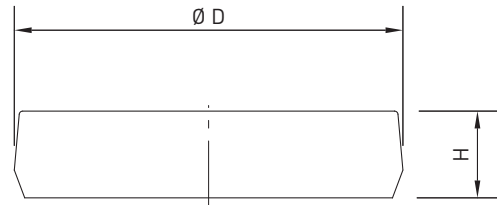

Table 1.33 Cover caps for mounting holes of rails

Rail	Screw	Article number			$\varnothing D$ [mm]	Height H [mm]
		Plastic	Brass	Steel		
EGR15R	M3	C3	C3-M	—	6,0	1,2
EGR20R	M5	C5	C5-M	C5-ST	9,5	2,2
EGR25R	M6	C6	C6-M	C6-ST	11,0	2,5
EGR30R	M6	C6	C6-M	C6-ST	11,0	2,5
EGR35R	M8	C8	C8-M	C8-ST	14,0	3,3
EGR15U	M4	C4	C4-M	—	7,5	1,1
EGR30U	M8	C8	C8-M	C8-ST	14,0	3,3

Linear Guideways

EG/QE series

1.3.11 Sealing systems

Various sealing systems are available for HIWIN blocks. You will find an overview on page 89. The table below shows the total length of the blocks with the different sealing systems. Sealing systems suitable for these sizes are available.

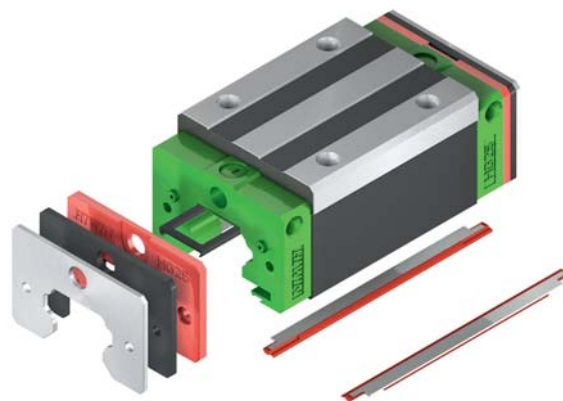

Table 1.34 Total length of blocks with different sealing systems

Series/ size	Total length L					
	SS	DD	ZZ	KK	SW	ZWX
EG_15S	40,1	44,1	41,7	45,7	—	—
QE_15S	40,1	44,1	42,1	46,1	—	—
EG_15C	56,8	60,8	58,4	62,4	—	—
QE_15C	56,8	60,8	58,8	62,8	—	—
EG_20S	50,0	54,0	51,6	55,6	—	—
QE_20S	50,0	54,0	52,0	56,0	—	—
EG_20C	69,1	73,1	70,7	74,7	—	—
QE_20C	69,1	73,1	71,1	75,1	—	—
EG_25S	59,1	63,1	61,1	65,1	—	—
QE_25S	60,1	65,1	62,1	67,1	—	—
EG_25C	82,6	86,6	84,6	88,6	—	—
QE_25C	83,6	88,6	85,6	90,6	—	—
EG_30S	69,5	73,5	71,5	75,5	—	—
QE_30S	67,5	72,5	69,5	74,5	—	—
EG_30C	98,1	102,1	100,1	104,1	—	—
QE_30C	96,1	101,1	98,1	103,1	—	—
EG_35S	75,0	79,0	78,0	82,0	—	—
QE_35S	76,0	80,0	79,0	83,0	—	—
EG_35C	108,0	112,0	111,0	115,0	—	—
QE_35C	108,0	112,0	111,0	115,0	—	—

Unit: mm

1.3.11.1 Designation of sealing sets

The sealing sets are always supplied along with the assembly material and include the parts needed in addition to the standard seal.

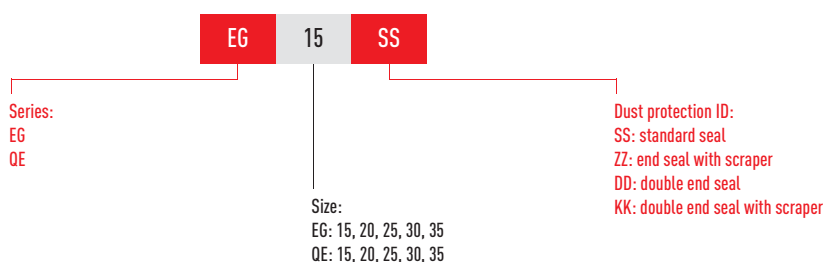

1.3.12 Friction

The table shows the maximum frictional resistance of the individual end seal. Depending on sealing setup (SS, ZZ, DD, KK), the value may have to be multiplied. The values indicated apply to blocks on uncoated rails. Higher friction forces occur on coated rails.

Table 1.36 Frictional resistance of single-lipped seals

Series/size	Friction force [N]	Series/size	Friction force [N]
EG_15	1,0	QE_15	1,1
EG_20	1,0	QE_20	1,4
EG_25	1,0	QE_25	1,7
EG_30	1,5	QE_30	2,1
EG_35	2,0	QE_35	2,3

1.3.13 Tolerances depending on accuracy class

The EG and QE series are available in five accuracy classes depending on parallelism between block and rail, height accuracy H and accuracy of width N. The choice of accuracy class is determined by the machine requirements.

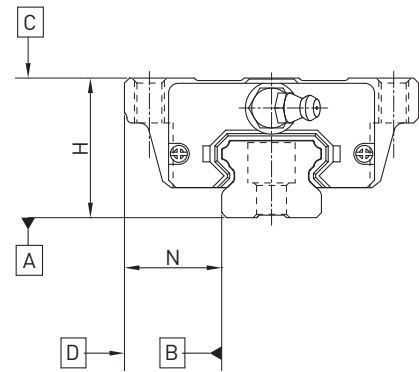

1.3.13.1 Parallelism

Parallelism of stop surfaces D and B of block and rail and parallelism of top of block C to mounting surface A of rail. Ideal linear guideway installation is required, as is a measurement in the centre of the block.

Table 1.37 Tolerance of parallelism between block and rail

Rail length [mm]	Accuracy class				
	C	H	P	SP	UP
– 100	12	7	3	2	2
100 – 200	14	9	4	2	2
200 – 300	15	10	5	3	2
300 – 500	17	12	6	3	2
500 – 700	20	13	7	4	2
700 – 900	22	15	8	5	3
900 – 1100	24	16	9	6	3
1100 – 1500	26	18	11	7	4
1500 – 1900	28	20	13	8	4
1900 – 2500	31	22	15	10	5
2500 – 3100	33	25	18	11	6
3100 – 3600	36	27	20	14	7
3600 – 4000	37	28	21	15	7

Unit: μm

Linear Guideways

EG/QE series

1.3.13.2 Accuracy – height and width

Height tolerance H

Permissible absolute dimension variance of height H, measured between centre of screw-on surface C and underside of rail A, with block in any position on the rail.

Height variance of H

Permissible variance of height H between several blocks on a rail, measured in the same rail position.

Width tolerance N

Permissible absolute dimension variance of width N, measured between centre of screw-on surfaces D and B, with block in any position on the rail.

Width variance of N

Permissible variance of width N between several blocks on a rail, measured in the same rail position.

Table 1.38 Height and width tolerances of non-interchangeable types

Series/size	Accuracy class	Height tolerance of H	Width tolerance of N	Height variance of H	Width variance of N
EG_15, 20 QE_15, 20	Normal (C)	$\pm 0,1$	$\pm 0,1$	0,02	0,02
	High (H)	$\pm 0,03$	$\pm 0,03$	0,01	0,01
	Precision (P)	0 – 0,03	0 – 0,03	0,006	0,006
	Super precision (SP)	0 – 0,015	0 – 0,015	0,004	0,004
	Ultra precision (UP)	0 – 0,008	0 – 0,008	0,003	0,003
EG_25, 30, 35 QE_25, 30, 35	Normal (C)	$\pm 0,1$	$\pm 0,1$	0,02	0,03
	High (H)	$\pm 0,04$	$\pm 0,04$	0,015	0,015
	Precision (P)	0 – 0,04	0 – 0,04	0,007	0,007
	Super precision (SP)	0 – 0,02	0 – 0,02	0,005	0,005
	Ultra precision (UP)	0 – 0,01	0 – 0,01	0,003	0,003

Unit: mm

Table 1.39 Height and width tolerances of interchangeable types

Series/size	Accuracy class	Height tolerance of H	Width tolerance of N	Height variance of H	Width variance of N
EG_15, 20 QE_15, 20	Normal (C)	$\pm 0,1$	$\pm 0,1$	0,02	0,02
	High (H)	$\pm 0,03$	$\pm 0,03$	0,01	0,01
	Precision (P)	$\pm 0,015$	$\pm 0,015$	0,006	0,006
EG_25, 30, 35 QE_25, 30, 35	Normal (C)	$\pm 0,1$	$\pm 0,1$	0,02	0,03
	High (H)	$\pm 0,04$	$\pm 0,04$	0,015	0,015
	Precision (P)	$\pm 0,02$	$\pm 0,02$	0,007	0,007

Unit: mm

1.3.14 Permissible mounting surface tolerances

Once the requirements relating to the accuracy of the mounting surfaces are met, the good accuracy, rigidity and lifetime of the EG and QE series linear guideways are achieved.

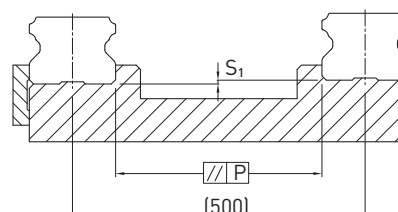

Parallelism of the reference surface (P)

Table 1.40 Maximum tolerance for parallelism (P)

Series/size	Preload class		
	Z0	ZA	ZB
EG/QE_15	25	18	—
EG/QE_20	25	20	18
EG/QE_25	30	22	20
EG/QE_30	40	30	27
EG/QE_35	50	35	30

Unit: μm

Table 1.41 Maximum height tolerance of reference surface (S₁)

Series/size	Preload class		
	Z0	ZA	ZB
EG/QE_15	130	85	—
EG/QE_20	130	85	50
EG/QE_25	130	85	70
EG/QE_30	170	110	90
EG/QE_35	210	150	120

Unit: μm

1.3.15 Shoulder heights and fillets

Improper shoulder heights and fillets of mounting surfaces will cause a deviation in accuracy and the interference with the chamfered part of the rail or block. As long as the recommended shoulder heights and fillets are followed, installation inaccuracies should be eliminated.

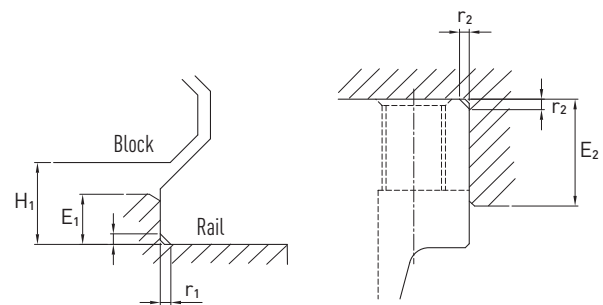

Table 1.42 Shoulder heights and fillets

Series/size	Max. edge radius r_1	Max. edge radius r_2	Shoulder height of reference edge of rail E_1	Shoulder height of reference edge of block E_2	Clearance under block H_1
EG/QE_15	0,5	0,5	2,7	5,0	4,5
EG/QE_20	0,5	0,5	5,0	7,0	6,0
EG/QE_25	1,0	1,0	5,0	7,5	7,0
EG/QE_30	1,0	1,0	7,0	7,0	10,0
EG_35	1,0	1,0	7,5	9,5	11,0
QE_35	1,0	1,5	7,5	9,5	11,0

Unit: mm

Linear Guideways

WE series

1.4 Linear Guideway Series WE

1.4.1 Properties of the linear guideway, series WE

The HIWIN linear guideways of the WE series are based on proven HIWIN technology. Their large rail width and low installation height permit a compact design and high torque loading capacity.

1.4.2 Structure of the WE series

- 4-row recirculation ball bearing guide
- 45° contact angle
- Ball retainers prevent the balls from falling out when the block is removed
- Low installation height
- Wide linear guideway for high torque loading capacity
- Large mounting surface on block

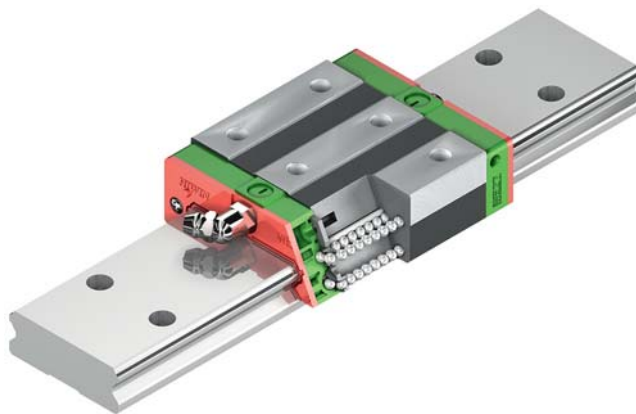

Fig. Structure of the WE series

1.4.3 Advantages

- Compact and low-cost design thanks to high torque loading capacity
- High efficiency thanks to low friction losses

- The block's large mounting surface supports the transfer of higher torques
- The 45° arrangement of ball tracks permits high loading from all directions

- Optimized geometry and high loading capacity thanks to FEM analysis of rail and block

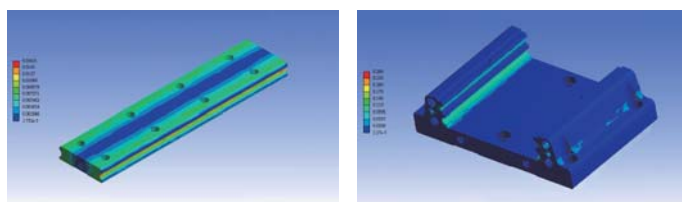
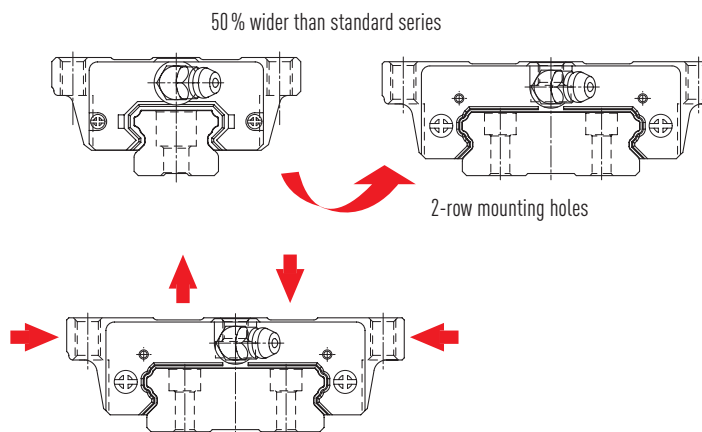

1.4.4 Article numbers of the WE series

For WE linear guideways, a distinction is made between interchangeable and non-interchangeable models. The dimensions of both models are the same. The main difference is that the block and rail in the interchangeable models can be freely interchanged. Block and rail can therefore be ordered separately and fitted by the customer.

Their accuracy extends to class P. Given their stringent dimensional accuracy check, the interchangeable modules are a good choice for customers who do not use rails in pairs on one axis. Non-interchangeable linear guideways are always supplied pre-assembled. The article numbers of the series include the dimensions, model, accuracy class, preload etc.

1.4.4.1 Non-interchangeable models (custom-assembled)

- Item number of the fully assembled linear guideway

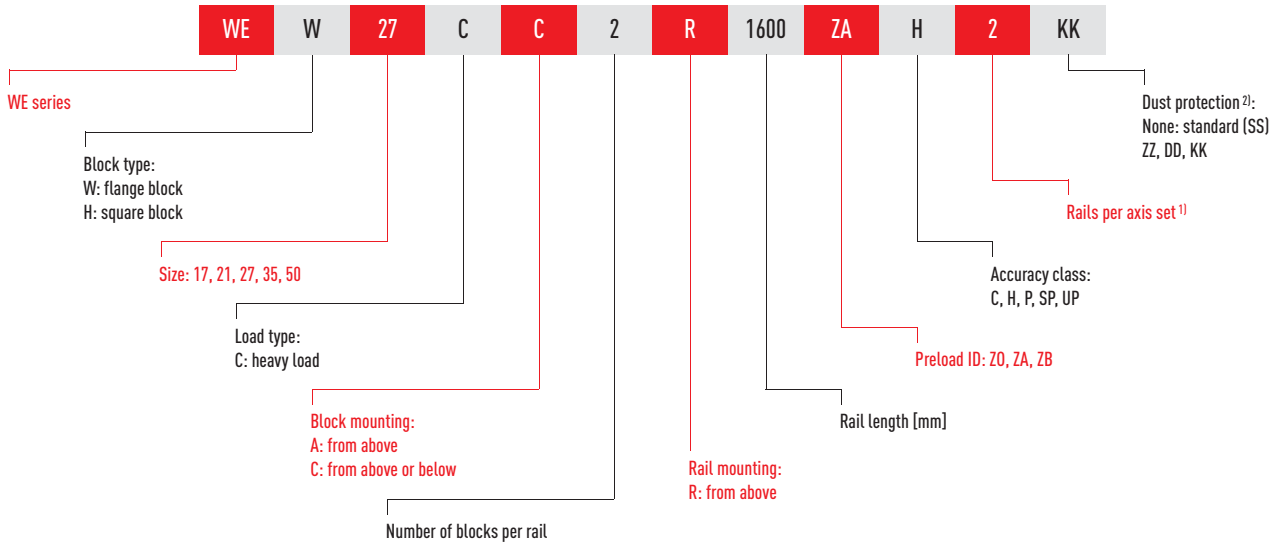

1.4.4.2 Interchangeable models

- Article number of WE block

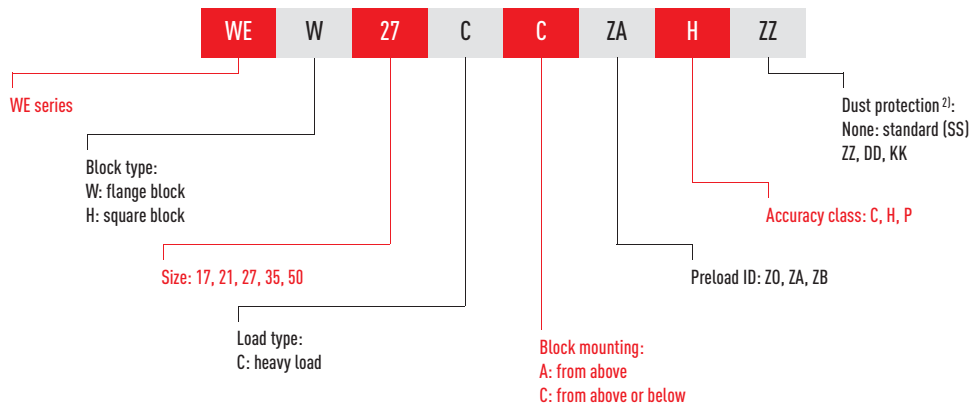

- Article number of WE rail

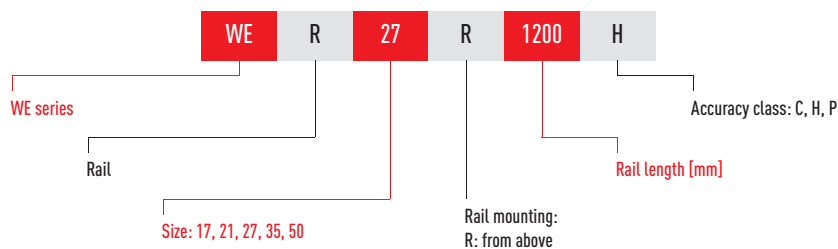

Note
¹⁾ The figure 2 is also a quantity, i.e. one item of the above-mentioned article consists of a pair of rails. No number is specified for individual rails.
²⁾ You will find an overview of the individual sealing systems on page 89.

Linear Guideways

WE series

1.4.5 Block types

HIWIN provides square and flange blocks for its linear guideways. Given their low height and larger mounting surface, flange blocks are better suited for large loads.

Table 1.43 Block types

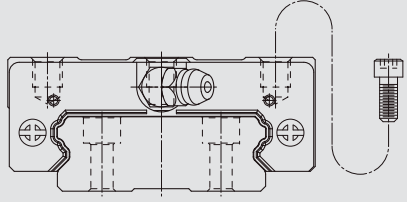
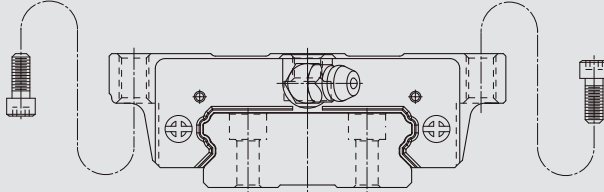
Type	Series Size	Structure	Height [mm]	Rail length [mm]	Typical application
Square type	WEH-CA		17 – 50	100 – 4.000	<ul style="list-style-type: none"> ○ Automation ○ Handling industry ○ Measuring and test technology ○ Semiconductor industry ○ Injection moulding machines ○ Linear axes
Flange type	WEW-CC				

1.4.6 Preload

1.4.6.1 Definition

Every rail type can be preloaded. Oversized balls are used for this purpose. Normally a linear guideway has negative clearance between track and balls to increase rigidity and precision. The curve shows that the rigidity doubles at higher preload.

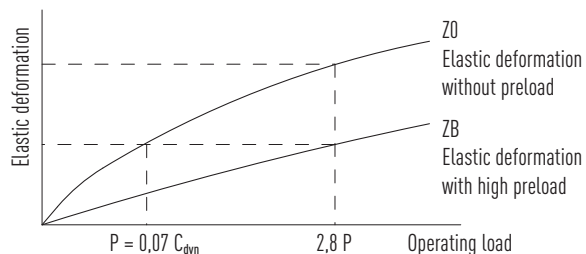

1.4.6.2 Preload ID

Table 1.44 Preload ID

ID	Preload		Application
Z0	Light preload	0 – 0,02 C_{dyn}	Constant load direction, low impact, low accuracy needed
ZA	Medium preload	0,03 – 0,05 C_{dyn}	High accuracy needed
ZB	High preload	0,06 – 0,08 C_{dyn}	High rigidity needed, vibration and impact

Note:

Preload classes for interchangeable guides Z0 and ZA. For non-interchangeable guides Z0, ZA, ZB.

1.4.7 Load ratings and torques

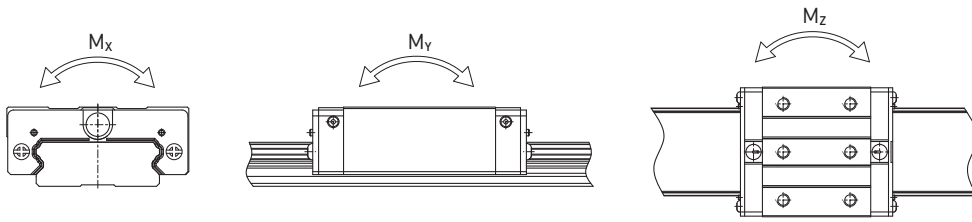

Table 1.45 Load ratings and torques for series WE

Series/size	Dynamic load rating C_{dyn} [N]*	Static load rating C_0 [N]	Dynamic moment [Nm]			Static moment [Nm]		
			M_x	M_y	M_z	M_{0x}	M_{0y}	M_{0z}
WE_17C	5230	9640	82	34	34	150	62	62
WE_21C	7210	13700	122	53	53	230	100	100
WE_27C	12400	21600	242	98	98	420	170	170
WE_35C	29800	49400	893	405	405	1480	670	670
WE_50C	61520	97000	2556	1244	1244	4030	1960	1960

* Dynamic load rating for travel distance of 50 000 m

1.4.8 Rigidity

Rigidity depends on preload. The adjacent formula can be used to determine deformation depending on rigidity.

$$\delta = \frac{P}{k}$$

δ : Deformation [μm]

P: Operating load [N]

k: Rigidity [N/ μm]

Table 1.46 Radial rigidity for series WE

Load class	Series/size	Preload		
		Z0	ZA	ZB
Heavy load	WE_17C	128	166	189
	WE_21C	154	199	228
	WE_27C	187	242	276
	WE_35C	281	364	416
	WE_50C	428	554	633

Unit: N/ μm

Linear Guideways

WE series

1.4.9 Dimensions of the WE blocks

1.4.9.1 WEH

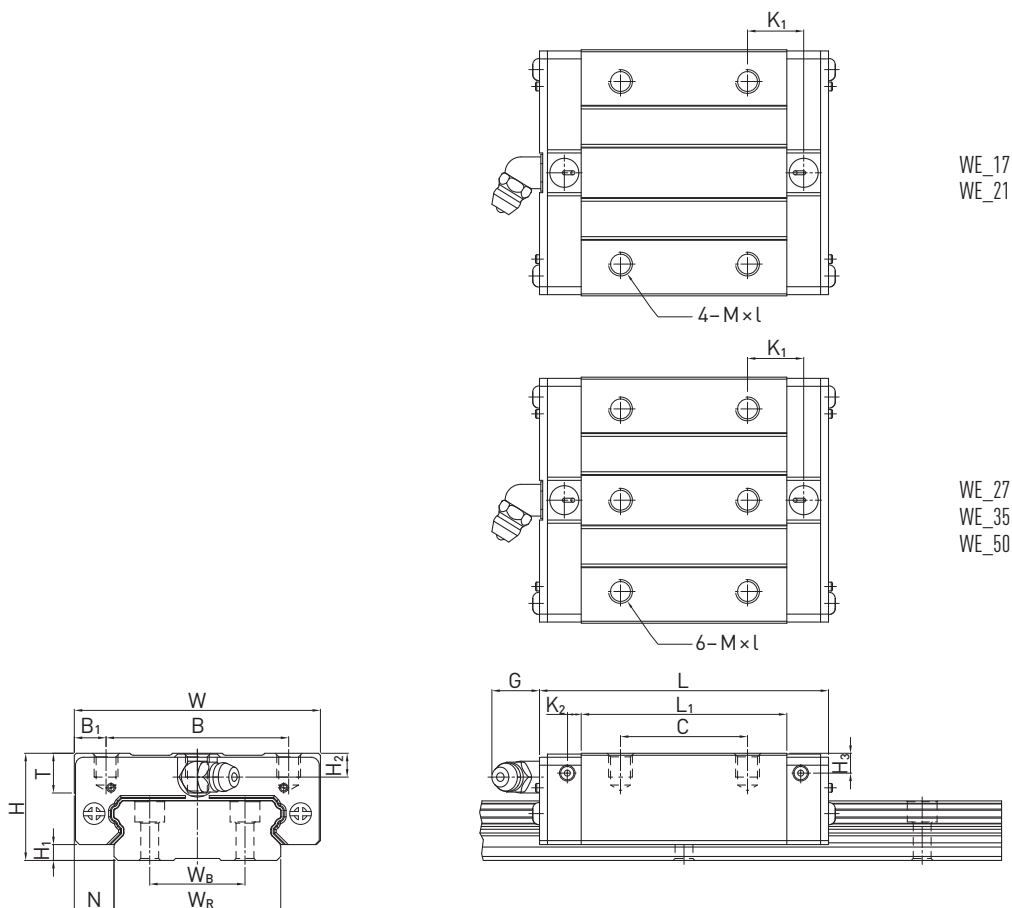

WE_17
WE_21

WE_27
WE_35
WE_50

Table 1.47 Dimensions of the block

Series/ size	Installation dimensions [mm]			Dimensions of the block [mm]														Load Ratings [N]		Weight [kg]
	H	H ₁	N	W	B	B ₁	C	L ₁	L	K ₁	K ₂	G	M × l	T	H ₂	H ₃	C _{dyn}	C ₀		
WEH17CA	17	2,5	8,5	50	29,0	10,5	15	35,0	50,6	—	3,10	4,9	M4 × 5	6,0	4,00	3,0	5230	9640	0,12	
WEH21CA	21	3,0	8,5	54	31,0	11,5	19	41,7	59,0	14,68	3,65	12,0	M5 × 6	8,0	4,50	4,2	7210	13700	0,20	
WEH27CA	27	4,0	10,0	62	46,0	8,0	32	51,8	72,8	14,15	3,50	12,0	M6 × 6	10,0	6,00	5,0	12400	21600	0,35	
WEH35CA	35	4,0	15,5	100	76,0	12,0	50	77,6	102,6	18,35	5,25	12,0	M8 × 8	13,0	8,00	6,5	29800	49400	1,10	
WEH50CA	50	7,5	20,0	130	100,0	15,0	65	112,0	140,0	28,05	6,00	12,9	M10 × 15	19,5	12,00	10,5	61520	97000	3,16	

For dimensions of rail, see page 44, for standard and optional lubrication adapter, see page 86.

1.4.9.2 WEW

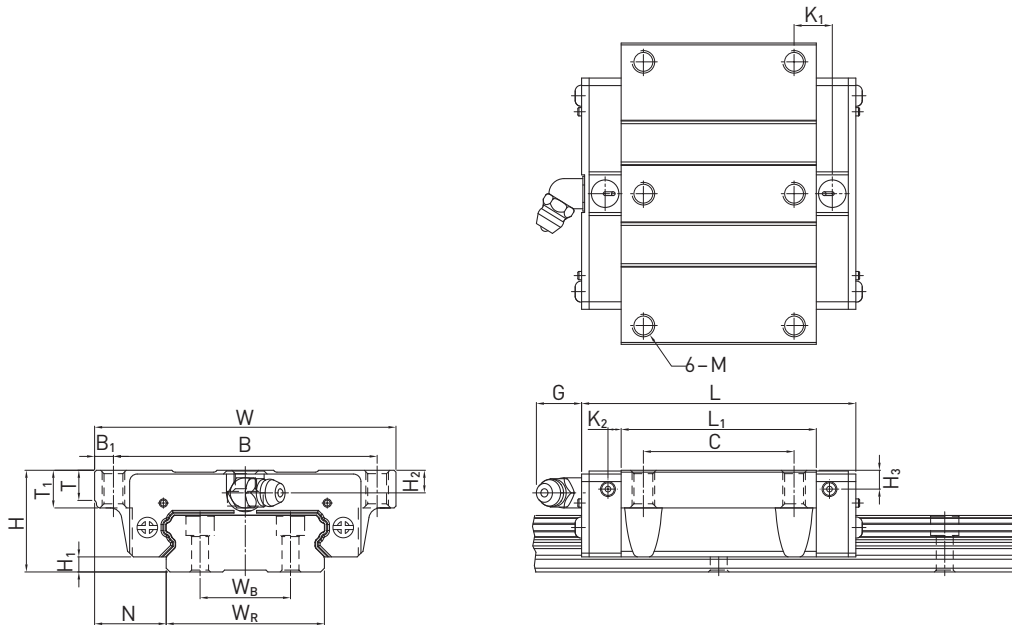

Table 1.48 Dimensions of the block

Series/ size	Installation dimensions [mm]			Dimensions of the block [mm]														Load Ratings [N]		Weight [kg]
	H	H ₁	N	W	B	B ₁	C	L ₁	L	K ₁	K ₂	G	M	T	T ₁	H ₂	H ₃	C _{dyn}	C ₀	
WEW17CC	17	2,5	13,5	60	53,0	3,5	26	35,0	50,6	—	3,10	4,9	M4	5,3	6,0	4,00	3,0	5230	9640	0,13
WEW21CC	21	3,0	15,5	68	60,0	4,0	29	41,7	59,0	9,68	3,65	12,0	M5	7,3	8,0	4,50	4,2	7210	13700	0,23
WEW27CC	27	4,0	19,0	80	70,0	5,0	40	51,8	72,8	10,15	3,50	12,0	M6	8,0	10,0	6,00	5,0	12400	21600	0,43
WEW35CC	35	4,0	25,5	120	107,0	6,5	60	77,6	102,6	13,35	5,25	12,0	M8	11,2	14,0	8,00	6,5	29800	49400	1,26
WEW50CC	50	7,5	36,0	162	144,0	9,0	80	112,0	140,0	20,55	6,00	12,9	M10	14,0	18,0	12,00	10,5	61520	97000	3,71

For dimensions of rail, see page 44, for standard and optional lubrication adapter, see page 86.

Linear Guideways

WE series

1.4.10 Dimensions of the WE rail

1.4.10.1 Dimensions of WER_R

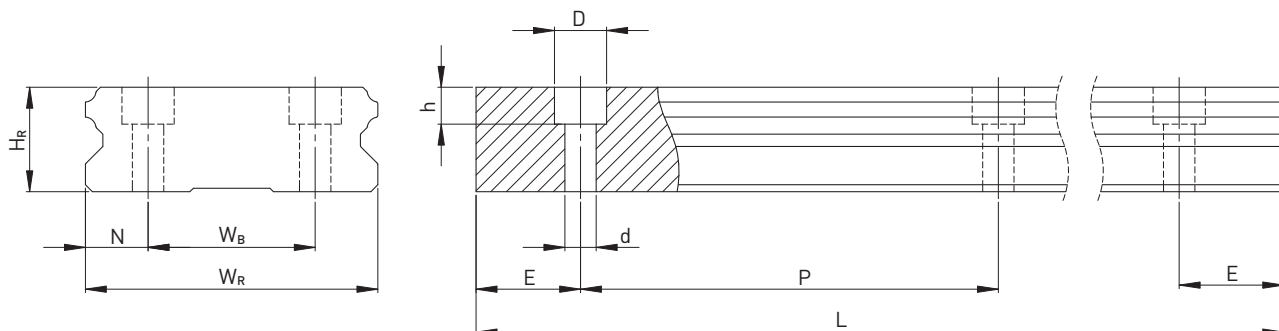

Table 1.49 Dimensions of rail WER_R

Series/ size	Assembly screw for rail [mm]	Dimensions of the rail [mm]							Max. length [mm]	$E_{1/2}$ min [mm]	$E_{1/2}$ max [mm]	Weight [kg/m]
		W_R	W_B	H_R	D	h	d	P				
WER17R	M4 × 12	33	18	9,3	7,5	5,3	4,5	40,0	4000	6	34	2,20
WER21R	M4 × 12	37	22	11,0	7,5	5,3	4,5	50,0	4000	6	44	3,00
WER27R	M4 × 16	42	24	15,0	7,5	5,3	4,5	60,0	4000	6	54	4,70
WER35R	M6 × 20	69	40	19,0	11,0	9,0	7,0	80,0	4000	8	72	9,70
WER50R	M8 × 25	90	60	24,0	14,0	12,0	9,0	80,0	4000	9	71	14,60

- Note
1. The tolerance for E is +0.5 to -1 mm for standard rails and 0 to -0.3 mm for joints.
 2. If the $E_{1/2}$ dimensions are not indicated, the maximum possible number of mounting holes will be determined under consideration of $E_{1/2}$ min.
 3. The rails are shortened to the required length. If the $E_{1/2}$ dimensions are not indicated, these will be carried out symmetrically.

1.4.10.2 Calculating the length of rails

HIWIN offers rails in customized lengths. To prevent the risk of the end of the rail becoming unstable, the value E must not exceed half of the distance between the mounting holes (P). At the same time, the value $E_{1/2}$ should be between $E_{1/2}$ min and $E_{1/2}$ max so that the mounting hole does not rupture.

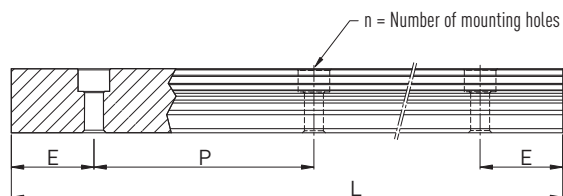

- L : Total length of the rail [mm]
 n : Number of mounting holes
 P : Distance between two mounting holes [mm]
 E : Distance from the middle of the last mounting hole to the end of the rail [mm]

1.4.10.3 Tightening torques for mounting bolts

Insufficient tightening of the mounting bolts compromises the function and precision of the linear guideways. The following tightening torques are recommended for the screw sizes.

Table 1.51 Tightening torques of the mounting bolts according to ISO 4762-12.9

Series/size	Screw size	Torque [Nm]	Series/size	Screw size	Torque [Nm]
WE_17	M4	4	WE_35	M6	13
WE_21	M4	4	WE_50	M8	30
WE_27	M4	4			

1.4.10.4 Cover caps for mounting holes of rails

The cover caps are used to keep the mounting holes free of chips and dirt. The standard plastic caps are provided with each rail. Optional cover caps must be ordered separately.

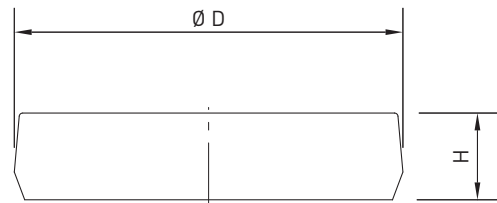

Table 1.52 Cover caps for mounting holes of rails

Rail	Screw	Article number			Ø D [mm]	Height H [mm]
		Plastic	Brass	Steel		
WER17R	M4	C4	C4-M	—	7,5	1,1
WER21R	M4	C4	C4-M	—	7,5	1,1
WER27R	M4	C4	C4-M	—	7,5	1,1
WER35R	M6	C6	C6-M	C6-ST	11,0	2,5
WER50R	M8	C8	C8-M	C8-ST	14,0	3,3

Linear Guideways

WE series

1.4.11 Sealing systems

Various sealing systems are available for HIWIN blocks. You will find an overview on page 89. The table below shows the total length of the blocks with the different sealing systems. Sealing systems suitable for these sizes are available.

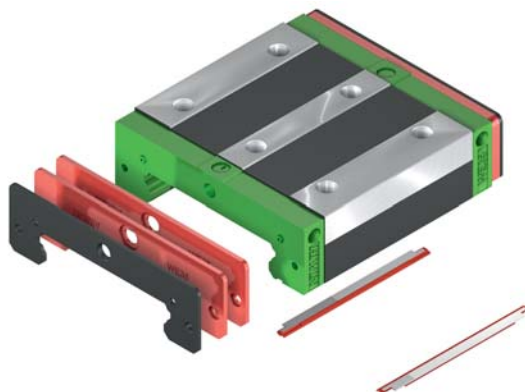

Table 1.53 Total length of block with different sealing systems

Series/ size	Total length L					
	SS	DD	ZZ	KK	SW	ZWX
WE_17C	50,6	53,8	52,6	55,8	—	—
WE_21C	59,0	63,0	61,0	65,0	—	—
WE_27C	72,8	76,8	74,8	78,8	—	—
WE_35C	102,6	106,6	105,6	109,6	—	—
WE_50C	140,0	145,0	142,0	147,0	—	—

Unit: mm

1.4.11.1 Designation of sealing sets

The sealing sets are always supplied along with the assembly material and include the parts needed in addition to the standard seal.

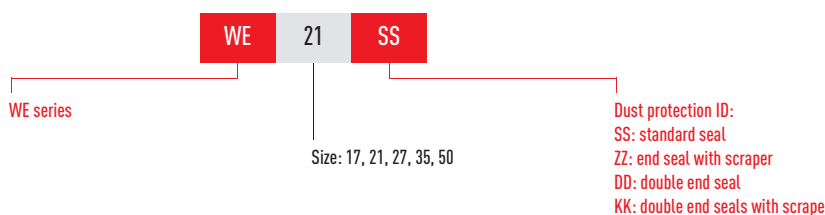

1.4.12 Friction

The table shows the maximum frictional resistance of the individual end seal. Depending on sealing setup (SS, ZZ, DD, KK), the value may have to be multiplied. The values indicated apply to blocks on uncoated rails. Higher friction forces occur on coated rails.

Table 1.55 Frictional resistance of single-lipped seals

Series/size	Friction force [N]	Series/size	Friction force [N]
WE_17	1,2	WE_35	3,9
WE_21	2,0	WE_50	3,9
WE_27	2,9		

1.4.13 Tolerances depending on accuracy class

The WE series are available in five accuracy classes depending on parallelism between block and rail, height accuracy H and accuracy of width N. The choice of accuracy class is determined by the machine requirements.

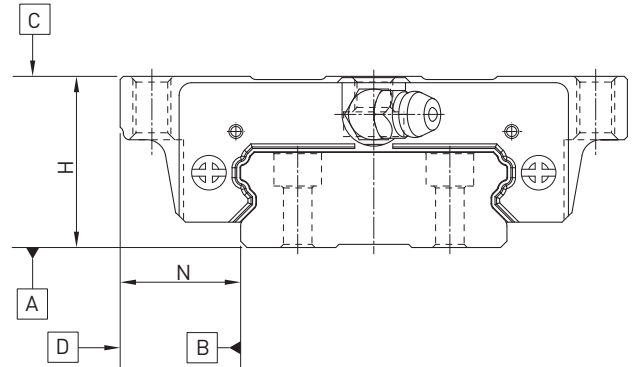

1.4.13.1 Parallelism

Parallelism of stop surfaces D and B of block and rail and parallelism of top of block C to mounting surface A of rail. Ideal linear guideway installation is required, as is a measurement in the centre of the block.

Table 1.56 Tolerance of parallelism between block and rail

Rail length [mm]	Accuracy class				
	C	H	P	SP	UP
- 100	12	7	3	2	2
100 - 200	14	9	4	2	2
200 - 300	15	10	5	3	2
300 - 500	17	12	6	3	2
500 - 700	20	13	7	4	2
700 - 900	22	15	8	5	3
900 - 1100	24	16	9	6	3
1100 - 1500	26	18	11	7	4
1500 - 1900	28	20	13	8	4
1900 - 2500	31	22	15	10	5
2500 - 3100	33	25	18	11	6
3100 - 3600	36	27	20	14	7
3600 - 4000	37	28	21	15	7

Unit: μm

Linear Guideways

WE series

1.4.13.2 Accuracy – height and width

Height tolerance H

Permissible absolute dimension variance of height H, measured between centre of screw-on surface C and underside of rail A, with block in any position on the rail.

Width tolerance N

Permissible absolute dimension variance of width N, measured between centre of screw-on surfaces D and B, with block in any position on the rail.

Height variance of H

Permissible variance of height H between several blocks on a rail, measured in the same rail position.

Width variance of N

Permissible variance of width N between several blocks on a rail, measured in the same rail position.

Table 1.57 Height and width tolerances of non-interchangeable types

Series/size	Accuracy class	Height tolerance of H	Width tolerance of N	Height variance of H	Width variance of N
WE_17, 21	Normal (C)	$\pm 0,1$	$\pm 0,1$	0,02	0,02
	High (H)	$\pm 0,03$	$\pm 0,03$	0,01	0,01
	Precision (P)	0 -0,03	0 -0,03	0,006	0,006
	Super precision (SP)	0 -0,015	0 -0,015	0,004	0,004
	Ultra precision (UP)	0 -0,008	0 -0,008	0,003	0,003
WE_27, 35	Normal (C)	$\pm 0,1$	$\pm 0,1$	0,02	0,03
	High (H)	$\pm 0,04$	$\pm 0,04$	0,015	0,015
	Precision (P)	0 -0,04	0 -0,04	0,007	0,007
	Super precision (SP)	0 -0,02	0 -0,02	0,005	0,005
	Ultra precision (UP)	0 -0,01	0 -0,01	0,003	0,003
WE_50	Normal (C)	$\pm 0,1$	$\pm 0,1$	0,03	0,03
	High (H)	$\pm 0,05$	$\pm 0,05$	0,02	0,02
	Precision (P)	0 -0,05	0 -0,05	0,01	0,01
	Super precision (SP)	0 -0,03	0 -0,03	0,01	0,01
	Ultra precision (UP)	0 -0,02	0 -0,02	0,01	0,01

Unit: mm

Table 1.58 Height and width tolerances of interchangeable types

Series/size	Accuracy class	Height tolerance of H	Width tolerance of N	Height variance of H	Width variance of N
WE_17, 21	Normal (C)	$\pm 0,1$	$\pm 0,1$	0,02	0,02
	High (H)	$\pm 0,03$	$\pm 0,03$	0,01	0,01
	Precision (P)	$\pm 0,015$	$\pm 0,015$	0,006	0,006
WE_27, 35	Normal (C)	$\pm 0,1$	$\pm 0,1$	0,02	0,03
	High (H)	$\pm 0,04$	$\pm 0,04$	0,015	0,015
	Precision (P)	$\pm 0,02$	$\pm 0,02$	0,007	0,007
WE_50	Normal (C)	$\pm 0,1$	$\pm 0,1$	0,03	0,03
	High (H)	$\pm 0,05$	$\pm 0,05$	0,015	0,02
	Precision (P)	$\pm 0,025$	$\pm 0,025$	0,007	0,01

Unit: mm

1.4.14 Permissible mounting surface tolerances

Once the requirements relating to the accuracy of the mounting surfaces are met, the good accuracy, rigidity and lifetime of the WE series linear guideways are achieved.

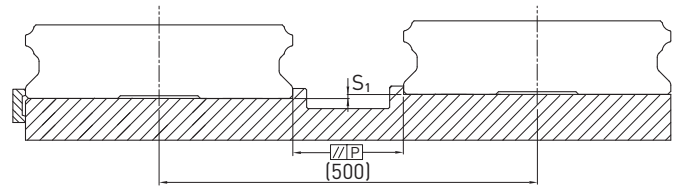

Parallelism of the reference surface (P)

Table 1.59 Maximum tolerance for parallelism (P)

Series/size	Preload class		
	Z0	ZA	ZB
WE_17	20	15	9
WE_21	25	18	9
WE_27	25	20	13
WE_35	30	22	20
WE_50	40	30	27

Unit: μm

Table 1.60 Maximum tolerance for height of reference surface (S_1)

Series/size	Preload class		
	Z0	ZA	ZB
WE_17	65	20	—
WE_21	130	85	45
WE_27	130	85	45
WE_35	130	85	70
WE_50	170	110	90

Unit: μm

1.4.15 Shoulder heights and fillets

Imprecise shoulder heights and fillets of mounting surfaces compromise precision and may lead to conflicts with the block or rail profiles. The following shoulder heights and edge profiles must be observed in order to avoid assembly problems.

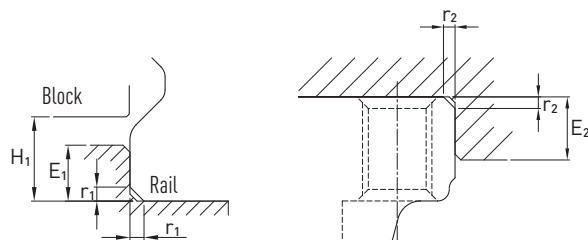

Table 1.61 Shoulder heights and fillets

Series/size	Max. edge radius r_1	Max. edge radius r_2	Shoulder height of reference edge of rail E_1	Shoulder height of reference edge of block E_2	Clearance under block H_1
WE_17	0,4	0,4	2,0	4,0	2,5
WE_21	0,4	0,4	2,5	5,0	3,0
WE_27	0,5	0,4	3,0	7,0	4,0
WE_35	0,5	0,5	3,5	10,0	4,0
WE_50	0,8	0,8	6,0	10,0	7,5

Unit: mm

Linear Guideways

MG series

1.5 Linear Guideway Series MG

1.5.1 Properties of the linear guideway, series MGN

The HIWIN linear guideway of the MGN series is based on proven HIWIN technology. The Gothic arch contact design absorbs loads in all directions and is particularly rigid and precise. Given its compact and lightweight design, it is particularly suited to use in small devices.

1.5.2 Structure of the MGN series

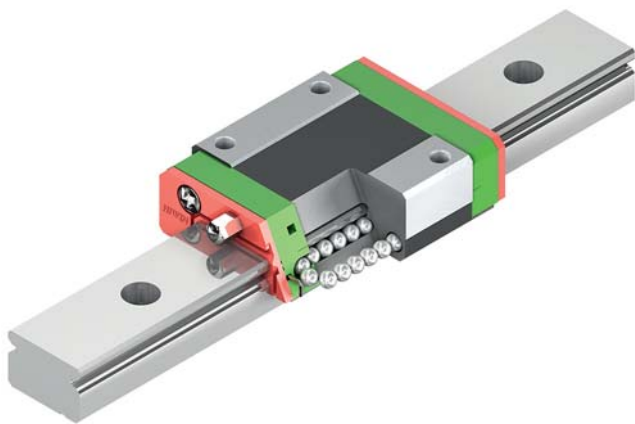

Fig. Structure of the MGN series

- 2-row recirculation ball bearing guide
- Gothic arch contact design
- Stainless steel block
- Rails made from standard or stainless steel
- Compact and lightweight design
- Steel balls are secured in the block by retaining wire
- Grease nipple available for MGN15
- End seal
- Bottom seal (optional for sizes 12 and 15)
- Interchangeable models are available in defined accuracy classes

1.5.3 Properties of the linear guideway, series MGW

The HIWIN linear guideway of the MGW series is based on proven HIWIN technology. The Gothic arch contact design absorbs loads in all directions and is particularly rigid and precise. The MGW series has a wider rail than the MGN series so can absorb considerably higher load torques.

1.5.4 Structure of the MGW series

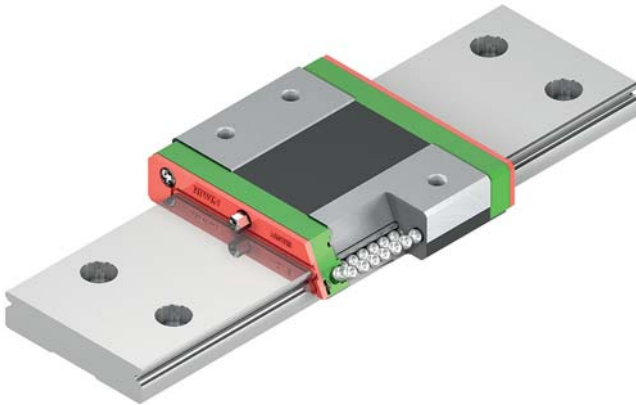

Fig. Structure of the MGW series

- 2-row recirculation ball bearing guide
- Gothic arch contact design
- Stainless steel block
- Rails made from standard or stainless steel
- Compact and lightweight design
- Steel balls are secured in the block by retaining wire
- Grease nipple available for MGW15
- End seal
- Bottom seal (optional for sizes 12 and 15)
- Interchangeable models are available in defined accuracy classes

1.5.5 Applications of the MG series

The MGN and MGW series can be used in many sectors, e.g. in the semiconductor industry, PCB population, medical technology, robot applications, measurement devices, office automation and other sectors needing miniature guides.

Linear Guideways

MG series

1.5.6 Article numbers of the MG series

For MGN and MGW linear guideways, a distinction is made between interchangeable and non-interchangeable models. The dimensions of both models are the same. The main difference is that the block and rail in the interchangeable models can be freely interchanged. Block and rail can therefore be ordered separately and fitted by the customer.

Given their stringent dimensional accuracy check, the interchangeable modules are a good choice for customers who do not use rails in pairs on one axis. The article numbers include the dimensions, model, accuracy class, preload etc.

1.5.6.1 Non-interchangeable models (custom-assembled)

- Article number of the fully assembled linear guideway

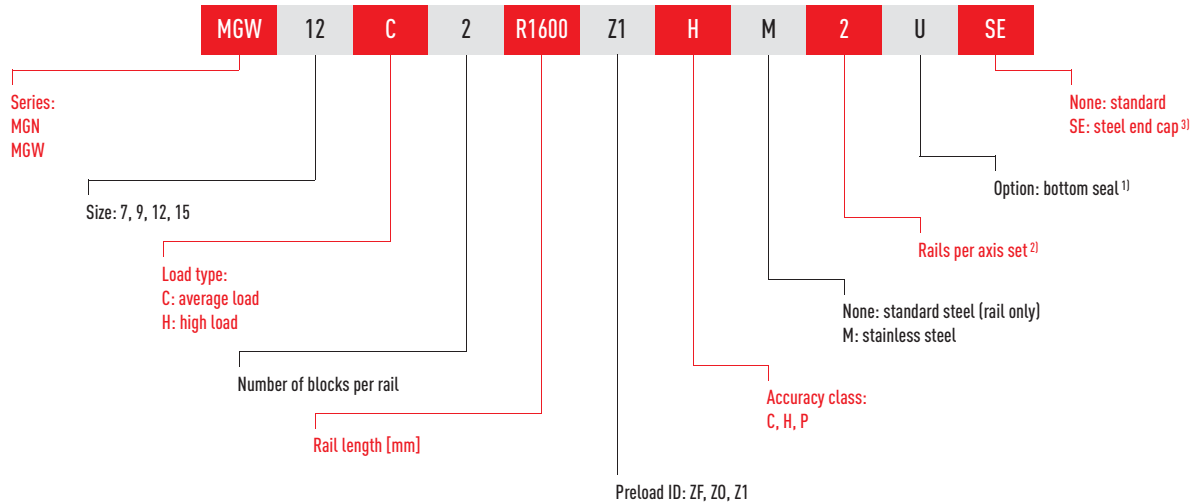

1.5.6.2 Interchangeable models

- Article number of MG block

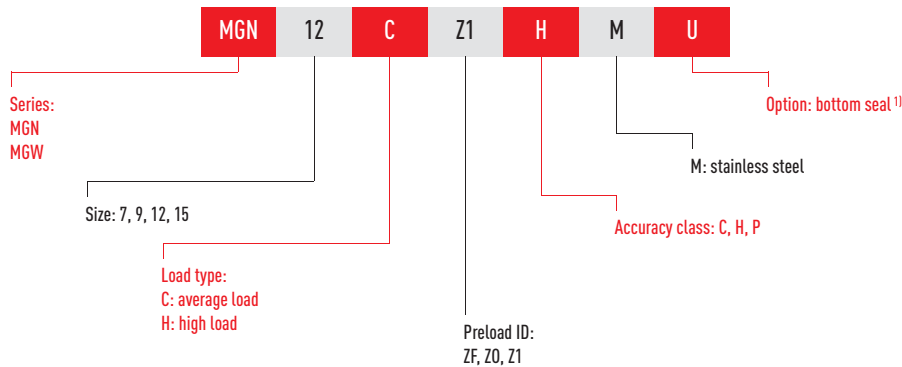

- Article number of MG rail

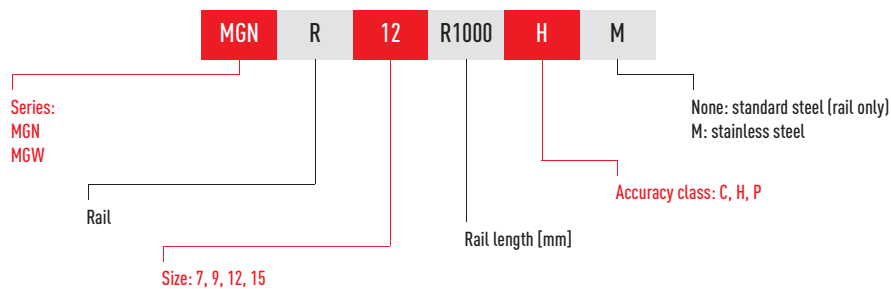

Note

¹⁾ Bottom seal is available for MGN and MGW series in sizes 12 and 15.

²⁾ The figure 2 is also a quantity, i.e. one item of the above-mentioned article consists of a pair of rails. No number is specified for individual rails.

³⁾ Only available for MGN 9, 12, 15 and MGW 12, 15.

1.5.7 Preload

The MGN/MGW series offers three preload classes for various applications.

Table 1.62 Preload ID

ID	Preload	Accuracy class
ZF	Slight play: 4 – 10 µm	C, H
Z0	Zero-play, very slight preload	C – P
Z1	slight preload: 0 – 0.02 C _{dyn}	C – P

1.5.8 Load ratings and torques

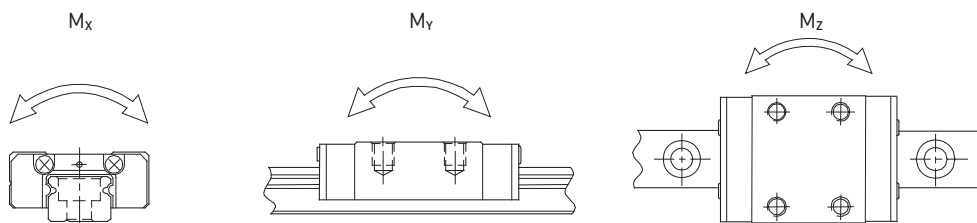

Table 1.63 Load ratings and torques for MG series

Series/size	Dynamic load rating C _{dyn} [N]*	Static load rating C ₀ [N]	Dynamic moment [Nm]			Static moment [Nm]		
			M _x	M _y	M _z	M _{0x}	M _{0y}	M _{0z}
MGN07C	980	1245	3	2	2	4,7	2,8	2,8
MGN07H	1370	1960	5	3	3	7,6	4,8	4,8
MGN09C	1860	2550	8	5	5	11,8	7,4	7,4
MGN09H	2550	4020	12	12	12	19,6	18,6	18,6
MGN12C	2840	3920	18	10	10	25,5	13,7	13,7
MGN12H	3720	5880	24	23	23	38,2	36,3	36,3
MGN15C	4610	5590	37	18	18	45,1	21,6	21,6
MGN15H	6370	9110	52	41	41	73,5	57,8	57,8
MGW07C	1370	2060	10	4	4	15,7	7,1	7,1
MGW07H	1770	3140	13	8	8	23,5	15,5	15,5
MGW09C	2750	4120	27	12	12	40,1	18,0	18,0
MGW09H	3430	5890	32	20	20	54,5	34,0	34,0
MGW12C	3920	5590	50	19	19	70,3	27,8	27,8
MGW12H	5100	8240	64	36	36	102,7	57,4	57,4
MGW15C	6770	9220	149	42	42	199,3	56,7	56,7
MGW15H	8930	13380	196	80	80	299,0	122,6	122,6

* Dynamic load rating for travel distance of 50 000 m

Linear Guideways

MG series

1.5.9 Rigidity

Rigidity depends on preload. The adjacent formula can be used to determine deformation depending on rigidity.

$$\delta = \frac{P}{k}$$

δ : Deformation [μm]

P: Operating load [N]

k: Rigidity [N/ μm]

Table 1.64 Radial rigidity for series MGN

Load Class	Series/ size	Preload	
		Z0	Z1
Average load	MGN07C	26	33
	MGN09C	37	48
	MGN12C	44	56
	MGN15C	57	74
High load	MGN07H	39	51
	MGN09H	56	73
	MGN12H	63	81
	MGN15H	87	113

Unit: N/ μm

Table 1.65 Radial rigidity for series MGW

Load Class	Series/ size	Preload	
		Z0	Z1
Average load	MGW07C	38	49
	MGW09C	55	71
	MGW12C	63	81
	MGW15C	78	101
High load	MGW07H	54	70
	MGW09H	74	95
	MGW12H	89	114
	MGW15H	113	145

Unit: N/ μm

1.5.10 Dimensions of the MG block

1.5.10.1 MGN

MGN07, MGN09, MGN12

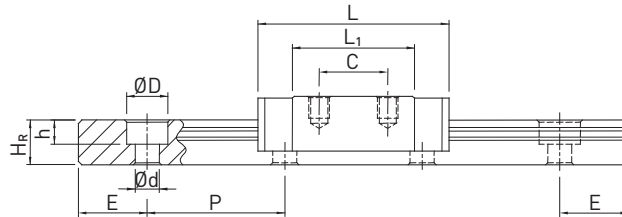
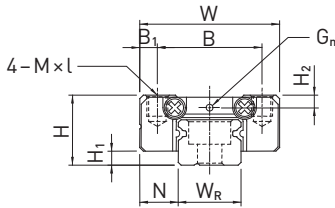

MGN15

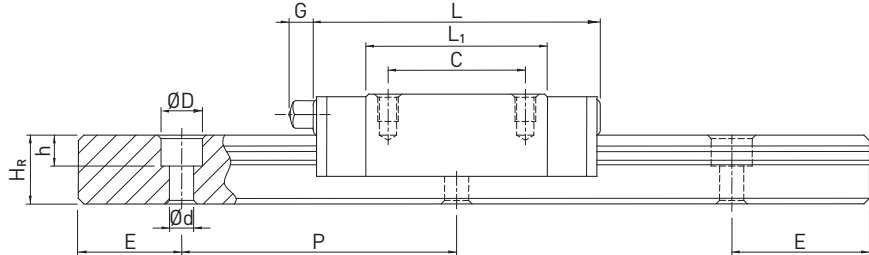
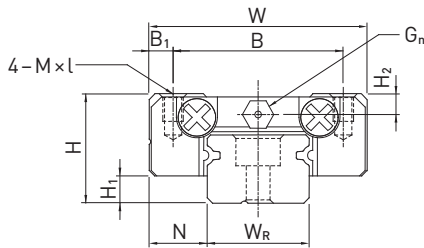

Table 1.66 Dimensions of the block

Series size	Installation dimensions [mm]			Dimensions of the block [mm]										Load Ratings [N]		Weight [kg]
	H	H ₁	N	W	B	B ₁	C	L ₁	L	G	G _n	M × l	H ₂	C _{dyn}	C ₀	
MGN07C	8	1,5	5,0	17	12	2,5	8	13,5	22,5	—	Ø 1,2	M2 × 2,5	1,5	980	1245	0,01
MGN07H							13	21,8	30,8					1370	1960	0,02
MGN09C	10	2	5,5	20	15	2,5	10	18,9	28,9	—	Ø 1,4	M3 × 3	1,8	1860	2550	0,02
MGN09H							16	29,9	39,9					2550	4020	0,03
MGN12C	13	3	7,5	27	20	3,5	15	21,7	34,7	—	Ø 2	M3 × 3,5	2,5	2840	3920	0,03
MGN12H							20	32,4	45,4					3720	5880	0,05
MGN15C	16	4	8,5	32	25	3,5	20	26,7	42,1	4,5	M3	M3 × 4	3	4610	5590	0,06
MGN15H							25	43,4	58,8					6370	9110	0,09

For dimensions of rail, see page 57, for standard and optional lubrication adapter, see page 86.

Linear Guideways

MG series

1.5.10.2 MGW

MGW07, MGW09, MGW12

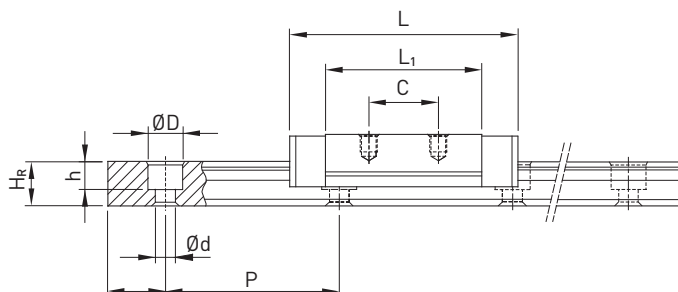
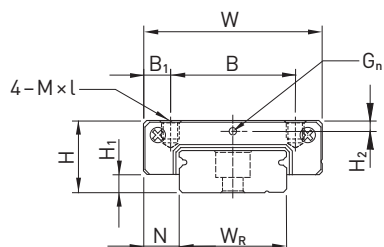

MGW15

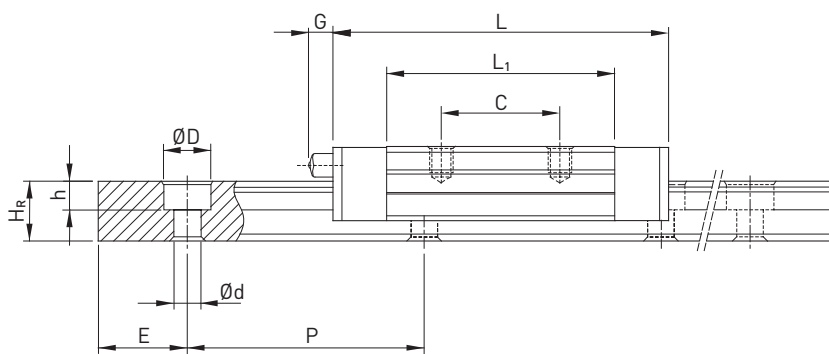
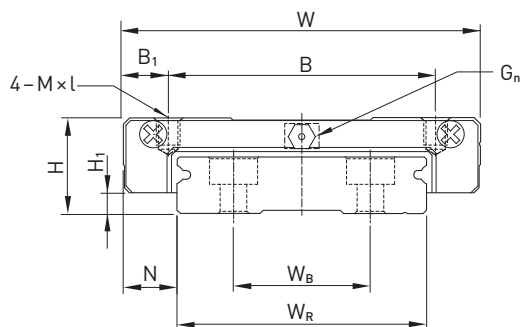

Table 1.67 Dimensions of the block

Series size	Installation dimensions [mm]			Dimensions of the block [mm]										Load Ratings [N]		Weight [kg]
	H	H ₁	N	W	B	B ₁	C	L ₁	L	G	G _n	M × l	H ₂	C _{dyn}	C ₀	
MGW07C	9	1,9	5,5	25	19	3	10	21	31,2	—	Ø1,2	M3 × 3	1,85	1370	2060	0,02
MGW07H							19	30,8	41,0					1770	3140	0,03
MGW09C	12	2,9	6,0	30	21	4,5	12	27,5	39,3	—	Ø1,4	M3 × 3	2,4	2750	4120	0,04
MGW09H							23	38,5	50,7					3430	5890	0,06
MGW12C	14	3,4	8,0	40	28	6	15	31,3	46,1	—	Ø2	M3 × 3,6	2,8	3920	5590	0,07
MGW12H							28	45,6	60,4					5100	8240	0,10
MGW15C	16	3,4	9,0	60	45	7,5	20	38	54,8	5,2	M3	M4 × 4,2	3,2	6770	9220	0,14
MGW15H							35	57	73,8					8930	13380	0,22

For dimensions of rail, see page 57, for standard and optional lubrication adapter, see page 86.

1.5.11 Dimensions of the MG rail

1.5.11.1 Dimensions of MGN_R

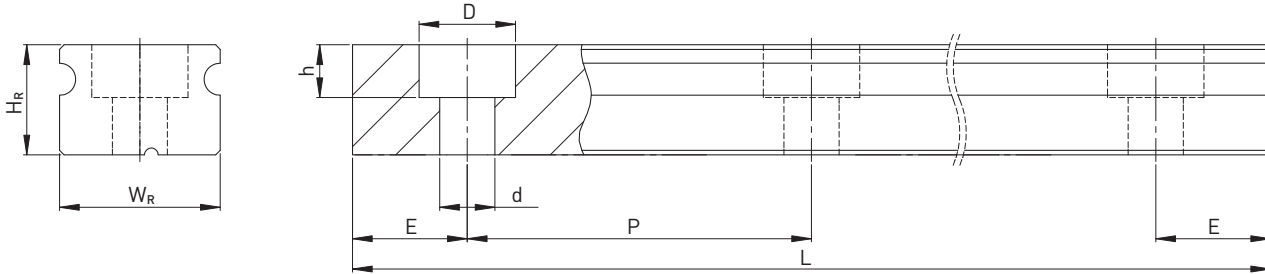

Table 1.68 Dimensions of rail MGN_R

Series/ size	Assembly screw for rail [mm]	Dimensions of rail [mm]						Max. length [mm]	Max. length $E_1 = E_2$	$E_{1/2}$ min [mm]	$E_{1/2}$ max [mm]	Weight [kg/m]
		W_R	H_R	D	h	d	P					
MGNR07R	M2 × 6	7	4,8	4,2	2,3	2,4	15,0	600	585	5	12	0,22
MGNR09R	M3 × 8	9	6,5	6,0	3,5	3,5	20,0	1200	1180	5	15	0,38
MGNR12R	M3 × 8	12	8,0	6,0	4,5	3,5	25,0	2000	1975	5	20	0,65
MGNR15R	M3 × 10	15	10,0	6,0	4,5	3,5	40,0	2000	1960	6	34	1,06

1.5.11.2 Dimensions of MGW_R

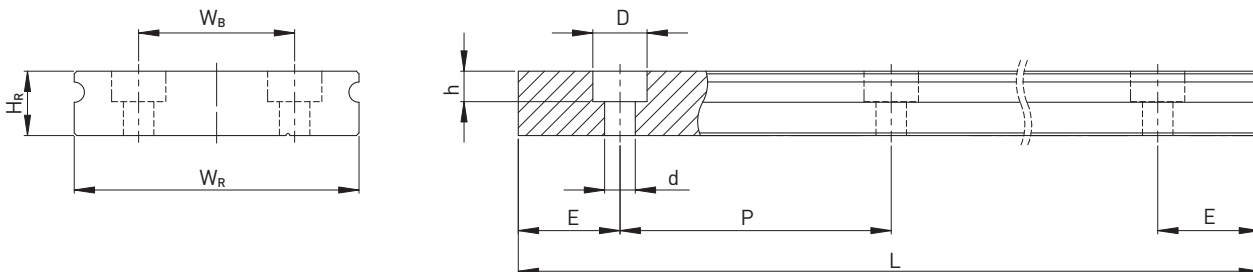

Table 1.69 Dimensions of rail MGW_R

Series/ size	Screws for rail [mm]	Dimensions of the rail [mm]							Max. length [mm]	Max. length $E_1 = E_2$ [mm]	$E_{1/2}$ min [mm]	$E_{1/2}$ max [mm]	Mass [kg/m]
		W_R	H_R	W_B	D	h	d	P					
MGWR07R	M3 × 6	14	5,2	—	6,0	3,2	3,5	30	600	570	6	24	0,51
MGWR09R	M3 × 8	18	7,0	—	6,0	4,5	3,5	30	1200	1170	6	24	0,91
MGWR12R	M4 × 8	24	8,5	—	8,0	4,5	4,5	40	2000	1960	8	32	1,49
MGWR15R	M4 × 10	42	9,5	23	8,0	4,5	4,5	40	2000	1960	8	32	2,86

- Note:
1. The tolerance for E is +0.5 to -1.0 mm for standard rails and 0 to -0.3 mm for joints.
 2. If the $E_{1/2}$ dimensions are not indicated, the maximum possible number of mounting holes will be determined under consideration of $E_{1/2}$ min.

Linear Guideways

MG series

1.5.11.3 Calculating the length of rails

HIWIN offers rails in customized lengths. To prevent the risk of the end of the rail becoming unstable, the value E must not exceed half of the distance between the mounting holes (P). At the same time, the value $E_{1/2}$ should be between $E_{1/2}$ min and $E_{1/2}$ max so that the mounting hole does not rupture.

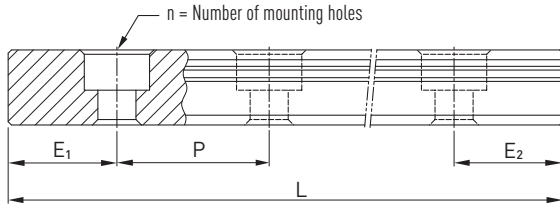

$$L = (n - 1) \cdot P + E_1 + E_2$$

- L: Total length of the rail [mm]
- n: Number of mounting holes
- P: Distance between two mounting holes [mm]
- $E_{1/2}$: Distance from the middle of the last mounting hole to the end of the rail [mm]

1.5.11.4 Tightening torques for mounting bolts

Insufficient tightening of the mounting bolts strongly compromises the precision of the linear guideway; the following tightening torques are therefore recommended for the relevant screw sizes.

Table 1.71 Tightening torques of the mounting bolts according to ISO 4762-12.9

Series/size	Screw size	Torque [Nm]	Series/size	Screw size	Torque [Nm]
MGN07	M2 × 6	0,6	MGW07	M3 × 6	2
MGN09	M3 × 8	2	MGW09	M3 × 8	2
MGN12	M3 × 8	2	MGW12	M4 × 8	4
MGN15	M3 × 10	2	MGW15	M4 × 10	4

1.5.11.5 Cover caps for mounting holes of rails

The cover caps are used to keep the mounting holes free of chips and dirt. The standard plastic caps are provided with each rail.



Table 1.72 Cover caps for mounting holes of rails

Rail	Screw	Article number		Ø D [mm]	Height H [mm]
		Plastic	Brass		
MGNR09R	M3	C3 ¹⁾	C3 ¹⁾	6,0	1,1
MGNR12R	M3	C3	C3	6,0	1,1
MGNR15R	M3	C3	C3	6,0	1,1
MGWR09R	M3	C3	C3	6,0	1,1
MGWR12R	M4	C4A	—	8,0	1,1
MGWR15R	M4	C4A	—	8,0	1,1

¹⁾ Standard: without cover caps, state in order if required. Only possible with cylinder head screws with a low head according to DIN 7984.

1.5.12 Dust protection

The blocks of the MG series are equipped on both sides with an end seal to protect against dirt as standard. Additional seals can be fitted underneath on the side of the block. Bottom seals can be ordered using the “+U” identifier in the article number. They are available as options for sizes 12 and 15. They cannot be fitted for sizes 7 and 9 due to the limited installation space H_1 . When fitting a bottom seal, the side mounting surface of the rail must not exceed H_1 .

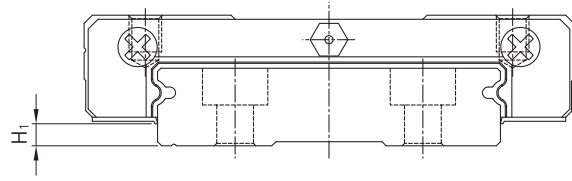

Table 1.74 Installation space H_1

Series/size	Bottom seal	H_1	Series/size	Bottom seal	H_1
MGN07	—	—	MGW07	—	—
MGN09	—	—	MGW09	—	—
MGN12	•	2,0	MGW12	•	2,6
MGN15	•	3,0	MGW15	•	2,6

1.5.13 Friction

The table shows the maximum frictional resistance of the seals of a block. The values indicated apply to blocks on uncoated rails. Higher friction forces occur on coated rails.

Table 1.76 Frictional resistance for standard block

Series/size	Friction force [N]	Series/size	Friction force [N]
MGN07	0,1	MGW07	0,2
MGN09	0,1	MGW09	0,2
MGN12	0,2	MGW12	0,3
MGN15	0,2	MGW15	0,3

1.5.14 Tolerances depending on accuracy class

The MG series are available in three accuracy classes depending on parallelism between block and rail, height accuracy H and accuracy of width N . The choice of accuracy class is determined by the machine requirements.

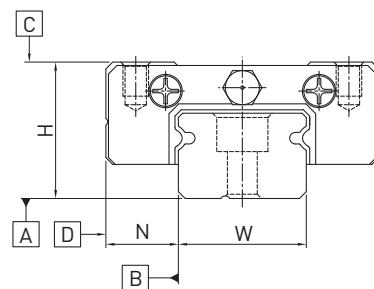

Linear Guideways

MG series

1.5.14.1 Parallelism

Parallelism of stop surfaces D and B of block and rail and parallelism of top of block C to mounting surface A of rail. Ideal linear guideway installation is required, as is a measurement in the centre of the block.

Table 1.78 Tolerance of parallelism between block and rail

Rail length [mm]	Accuracy class			Rail length [mm]	Accuracy class		
	C	H	P		C	H	P
- 50	12	6	2	315 – 400	18	11	6
50 – 80	13	7	3	400 – 500	19	12	6
80 – 125	14	8	3,5	500 – 630	20	13	7
125 – 200	15	9	4	630 – 800	22	14	8
200 – 250	16	10	5	800 – 1000	23	16	9
250 – 315	17	11	5	1000 – 1200	25	18	11

Unit: μm

1.5.14.2 Accuracy – height and width

Height tolerance H

Permissible absolute dimension variance of height H, measured between centre of screw-on surface C and underside of rail A, with block in any position on the rail.

Width tolerance N

Permissible absolute dimension variance of width N, measured between centre of screw-on surfaces D and B, with block in any position on the rail.

Height variance of H

Permissible variance of height H between several blocks on a rail, measured in the same rail position.

Width variance of N

Permissible variance of width N between several blocks on a rail, measured in the same rail position.

Table 1.79 Height and width tolerances of non-interchangeable models

Series/size	Accuracy class	Height tolerance of H	Width tolerance of N	Height variance of H	Width variance of N
MG_07 – MG_15	Normal (C)	$\pm 0,04$	$\pm 0,04$	0,03	0,03
	High (H)	$\pm 0,02$	$\pm 0,025$	0,015	0,02
	Precision (P)	$\pm 0,01$	$\pm 0,015$	0,007	0,01

Unit: mm

Table 1.80 Height and width tolerances of interchangeable types

Series/size	Accuracy class	Height tolerance of H	Width tolerance of N	Height variance of H	Width variance of N	Height variance of H ¹⁾
MG_07 – MG_15	Normal (N)	$\pm 0,04$	$\pm 0,04$	0,03	0,03	0,07
	High (H)	$\pm 0,02$	$\pm 0,025$	0,015	0,02	0,04
	Precision (P)	$\pm 0,01$	$\pm 0,015$	0,007	0,01	0,02

Unit: mm

¹⁾ Permissible deviation of height H between several blocks on a pair of rails

1.5.15 The accuracy tolerance of rail-mounting surface

Once the demands on the accuracy of the mounting surfaces are met, the high accuracy, rigidity and durability of the linear guideways of the MG series are reached.

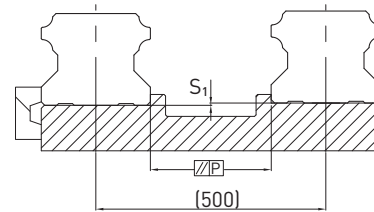

Parallelism tolerance of reference surface (P)

Table 1.81 Maximum tolerances for the parallel alignment (P)

Series/size	Preload class		
	ZF	Z0	Z1
MG_07	3	3	3
MG_09	4	4	3
MG_12	9	9	5
MG_15	10	10	6

Unit: μm

Table 1.82 Maximum tolerance of reference surface height (S₁)

Series/size	Preload class		
	ZF	Z0	Z1
MG_07	25	25	3
MG_09	35	35	6
MG_12	50	50	12
MG_15	60	60	20

Unit: μm

Table 1.83 Requirements to the mounting surface

Series/size	Required evenness of the mounting surface
MG_07	0,025/200
MG_09	0,035/200
MG_12	0,050/200
MG_15	0,060/200

Unit: mm

Note: The values above are suitable for preload of ZF/Z0. For preload of Z1 or using two (or more) rails on the same plane, 50% or less of the values above are recommended.

Linear Guideways

MG series

1.5.16 Shoulder heights and fillets

Imprecise shoulder heights and fillets of mounting surfaces compromise precision and may lead to conflicts with the block or rail profiles. The following shoulder heights and edge profiles must be observed in order to avoid assembly problems.

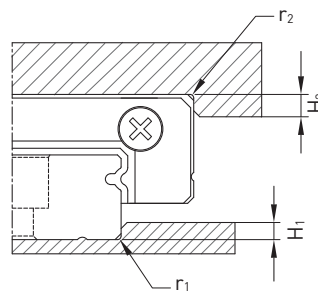

Table 1.84 Shoulder heights and fillets

Series/size	Max. edge radius r_1	Max. edge radius r_2	Shoulder height of H_1	Shoulder height of H_2
MGN07	0,2	0,2	1,2	3
MGN09	0,2	0,3	1,7	3
MGN12	0,3	0,4	1,7	4
MGN15	0,5	0,5	2,5	5
MGW07	0,2	0,2	1,7	3
MGW09	0,3	0,3	2,5	3
MGW12	0,4	0,4	3	4
MGW15	0,4	0,8	3	5

Unit: mm

1.6 Linear Guideway Series PM

1.6.1 Properties of the linear guideway, series PMN

The HIWIN linear guideway of the PMN series is based on the proven MGN series. Thanks to the optimised ball return in the plastic duct, the synchronous performance and quiet running are improved and the weight is reduced by around 20 %. The Gothic race profile absorbs loads in all directions and is particularly rigid and precise. Given its compact and lightweight design, it is particularly suited to use in small devices.

1.6.2 Structure of the PMN series

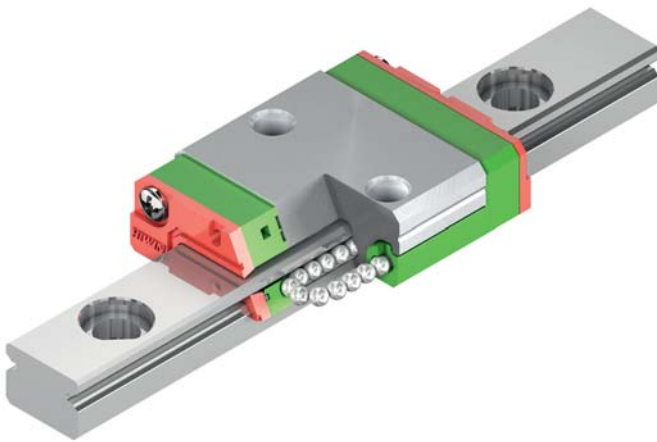

Fig. Structure of the PMN series

- 2-row recirculation ball bearing guide
- Gothic arch contact design
- Stainless steel block and balls
- Rails made from standard or stainless steel
- Compact and lightweight design
- Balls are secured in the block by retaining wire
- End seal
- Interchangeable models are available in defined accuracy classes
- Optimized ball deflection
- Improved synchronous performance
- Reduced weight

1.6.3 Applications of the PM series

The PM series was developed for use in restricted spaces, e.g. in the semiconductor industry, PCB population, medical technology, robot applications, measurement devices, office automation and other sectors needing miniature guides.

Linear Guideways

PM series

1.6.4 Article numbers of the PM series

For PM linear guideways, a distinction is made between interchangeable and non-interchangeable models. The dimensions of both models are the same. The main difference is that the block and rail in the interchangeable models can be freely interchanged. Block and rail can therefore be ordered separately and fitted by the customer.

Given their stringent dimensional accuracy check, the interchangeable modules are a good choice for customers who do not use rails in pairs on one axis. The article numbers include the dimensions, model, accuracy class, preload etc.

1.6.4.1 Non-interchangeable models (custom-assembled)

- Article number of the fully assembled linear guideway

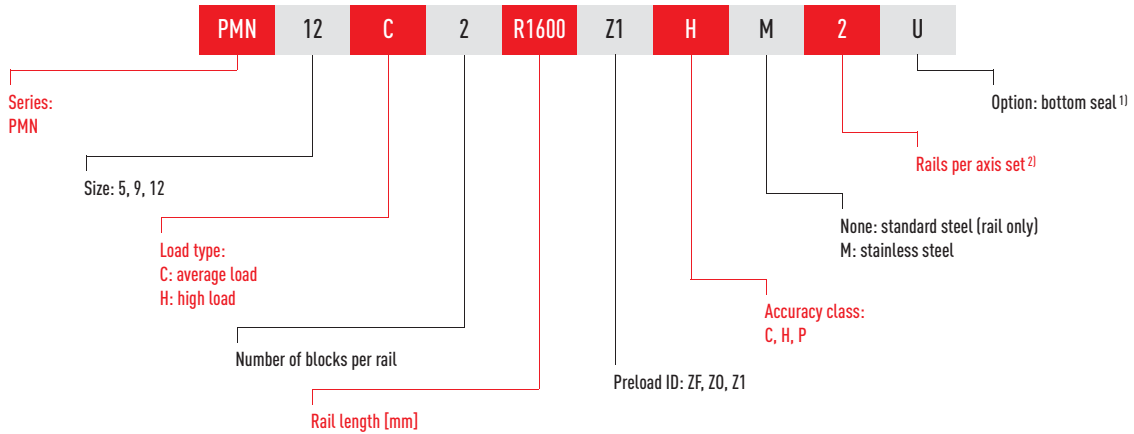

1.6.4.2 Interchangeable models

- Article number of PM block

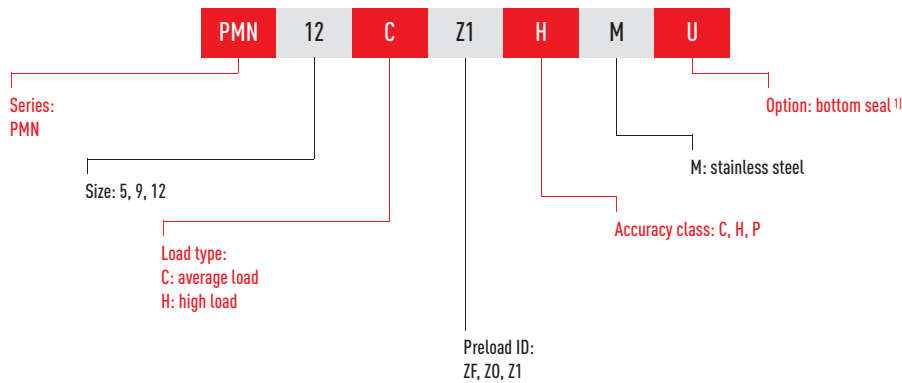

- Article number of PM rail

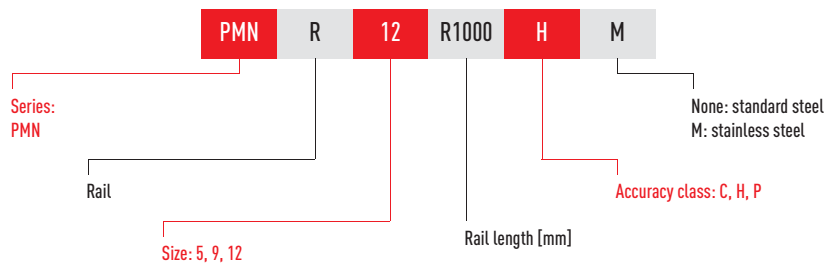

Note:
¹⁾ Bottom seal is available in sizes 9 and 12.
²⁾ The figure 2 is also a quantity, i.e. one item of the above-mentioned article consists of a pair of rails. No number is specified for individual rails.

1.6.5 Preload

The PM series offers three preload classes for various applications.

Table 1.85 Preload ID

ID	Preload	Accuracy class
ZF	Slight play: 4 – 10 µm	C, H
Z0	Zero-play, very slight preload	C – P
Z1	Slight preload: 0 – 0,02 C _{dyn}	C – P

1.6.6 Load ratings and torques

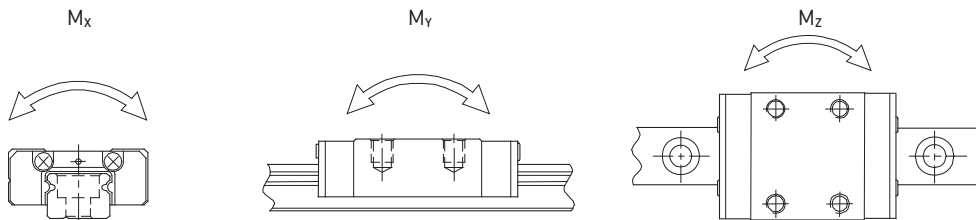

Table 1.86 Load ratings and torques for PM series

Series/size	Dynamic load rating C _{dyn} [N]*	Static load rating C ₀ [N]	Dynamic moment [Nm]			Static moment [Nm]		
			M _x	M _y	M _z	M _{0x}	M _{0y}	M _{0z}
PMN05C	540	840	1,3	0,8	0,8	2,0	1,3	1,3
PMN05H	667	1089	2,5	2,2	2,2	2,6	2,3	2,3
PMN09C	2010	2840	9,2	6,3	6,3	13,0	9,0	9,0
PMN12C	2840	3920	18,5	9,9	9,9	25,5	13,7	13,7

* Dynamic load rating for travel distance of 50 000 m

Linear Guideways

PM series

1.6.7 Dimensions of the PM blocks

1.6.7.1 PMN

PMN05

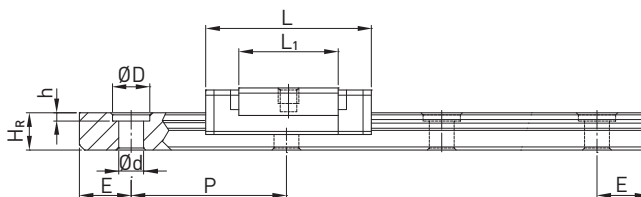
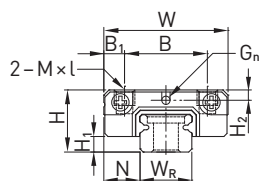

PMN09, PMN12

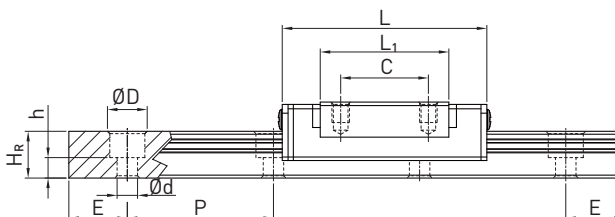
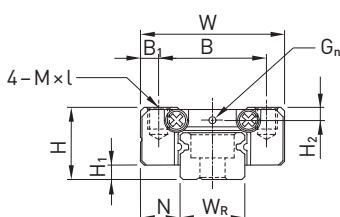

Table 1.87 Dimensions of the block

Series/ size	Installation dimensions [mm]			Dimensions of the block [mm]									Load ratings [N]		Weight [kg]
	H	H ₁	N	W	B	B ₁	C	L ₁	L	G _n	M × l	H ₂	C _{dyn}	C ₀	
PMN05C	6	1,5	3,5	12	8	2	—	9,6	16	Ø0,8	M2 × 1,5	1,0	540	840	0,008
PMN05H								12,6	19				667	1089	
PMN09C	10	2,2	5,5	20	15	2,5	10	19,4	30	Ø1,4	M3 × 8	1,8	2010	2840	0,012
PMN12C	13	3,0	7,5	27	20	3,5	15	22	35	Ø2	M3 × 3,5	2,5	2840	3920	0,025

For dimensions of rail, see page 67, for standard and optional lubrication adapter, see page 86.

1.6.8 Dimensions of the PM rail

1.6.8.1 Dimensions of PMN_R

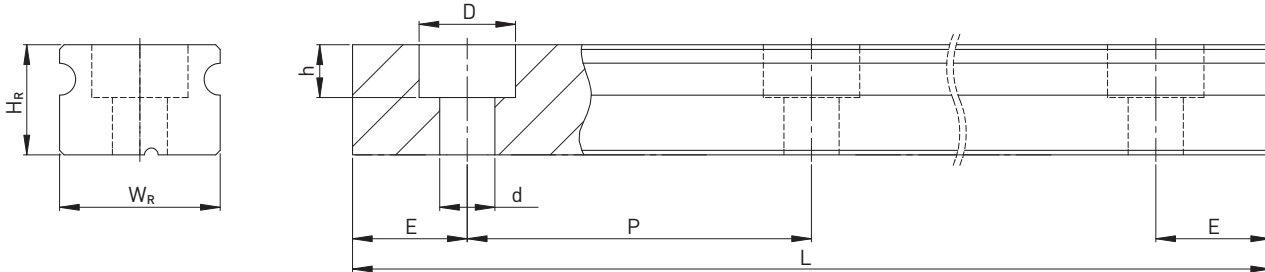

Table 1.88 Dimensions of rail PMN_R

Series/ size	Assembly screw for rail [mm]	Dimensions of rail [mm]						Max. length [mm]	Max. length $E_1 = E_2$	$E_{1/2}$ min [mm]	$E_{1/2}$ max [mm]	Weight [kg/m]
		W_R	H_R	D	h	d	P					
PMNR05R	M2 × 6	5	3,6	3,6	0,8	2,4	15,0	250	225	4	11	0,15
PMNR09R	M3 × 8	9	6,5	6,0	3,5	3,5	20,0	1200	1180	5	15	0,38
PMNR12R	M3 × 8	12	8,0	6,0	4,5	3,5	25,0	2000	1975	5	20	0,65

- Note:
1. The tolerance for E is +0.5 to -1.0 mm for standard rails and 0 to -0.3 mm for joints.
 2. If the $E_{1/2}$ dimensions are not indicated, the maximum possible number of mounting holes will be determined under consideration of $E_{1/2}$ min.

1.6.8.2 Calculating the length of rails

HIWIN offers rails in customised lengths. To prevent the risk of the end of the rail becoming unstable, the value E must not exceed half of the distance between the mounting holes (P). At the same time, the value $E_{1/2}$ should be between $E_{1/2}$ min and $E_{1/2}$ max so that the mounting hole does not rupture.

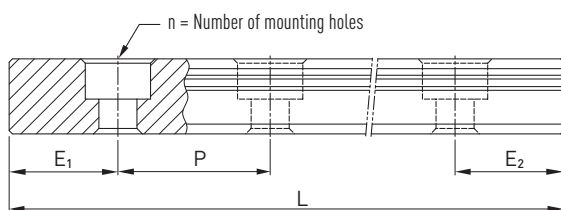

$$L = (n - 1) \cdot P + E_1 + E_2$$

L : Total length of the rail [mm]
 n : Number of mounting holes
 P : Distance between two mounting holes [mm]
 $E_{1/2}$: Distance from the middle of the last mounting hole to the end of the rail [mm]

1.6.8.3 Tightening torques for mounting bolts

Insufficient tightening of the mounting bolts strongly compromises the precision of the linear guideway; the following tightening torques are therefore recommended for the relevant screw sizes.

Table 1.90 Tightening torques of the mounting bolts according to ISO 4762-12.9

Series/size	Screw size	Torque [Nm]	Series/size	Screw size	Torque [Nm]
PMN05	M2 × 6	0,6	PMN12	M3 × 8	2,0
PMN09	M3 × 8	2,0			

Linear Guideways

PM series

1.6.8.4 Cover caps for mounting holes of rails

The cover caps are used to keep the mounting holes free of chips and dirt. The standard plastic caps are provided with each rail.

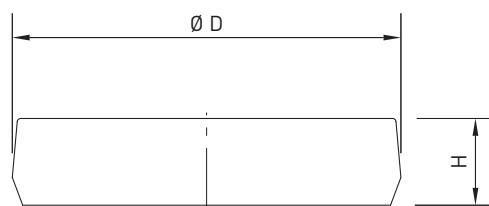

Table 1.91 Cover caps for mounting holes of rails

Rail	Screw	Article number		Ø D [mm]	Height H [mm]
		Plastic	Brass		
PMNR05R	—	—	—	—	—
PMNR09R	M3	C3 ¹⁾	C3 ¹⁾	6,0	1,1
PMNR12R	M3	C3	C3	6,0	1,1

¹⁾ Standard without cover caps, state in order if required. Only possible with cylinder head screws with a low head according to DIN 7984.

1.6.9 Dust protection

The blocks of the PM series are equipped on both sides with an end seal to protect against dirt as standard. Additional seals can be fitted underneath on the side of the block. Bottom seals can be ordered using the “+U” identifier in the article number. They are available as options for sizes 9 and 12. They cannot be fitted for size 5 due to the limited installation space H_1 . When fitting a bottom seal, the side mounting surface of the rail must not exceed H_1 .

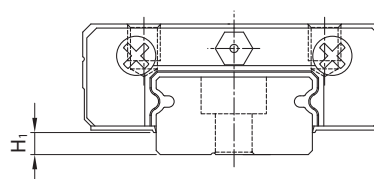

Table 1.93 Installation space H_1

Series/size	Bottom seal	H_1	Series/size	Bottom seal	H_1
PMN05	—	—	PMN12	•	2,0
PMN09	•	1,2			

1.6.10 Friction

The table shows the maximum frictional resistance of the seals of a block. The values indicated apply to blocks on uncoated rails. Higher friction forces occur on coated rails.

Table 1.95 Frictional resistance for standard block

Series/size	Friction force [N]	Series/size	Friction force [N]
PMN05	0,1	PMN12	0,2
PMN09	0,1		

1.6.11 Tolerances depending on accuracy class

The PM series are available in three accuracy classes depending on parallelism between block and rail, height accuracy H and accuracy of width N. The choice of accuracy class is determined by the machine requirements.

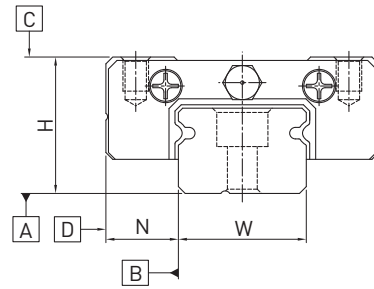

1.6.11.1 Parallelism

Parallelism of stop surfaces D and B of block and rail and parallelism of top of block C to mounting surface A of rail. Ideal linear guideway installation is required, as is a measurement in the centre of the block.

Table 1.97 Tolerance of parallelism between block and rail

Rail length [mm]	Accuracy class			Rail length [mm]	Accuracy class		
	C	H	P		C	H	P
- 50	12	6	2	1000 – 1200	25	18	11
50 – 80	13	7	3	1200 – 1300	25	18	11
80 – 125	14	8	3,5	1300 – 1400	26	19	12
125 – 200	15	9	4	1400 – 1500	27	19	12
200 – 250	16	10	5	1500 – 1600	28	20	13
250 – 315	17	11	5	1600 – 1700	29	20	14
315 – 400	18	11	6	1700 – 1800	30	21	14
400 – 500	19	12	6	1800 – 1900	30	21	15
500 – 630	20	13	7	1900 – 2000	31	22	15
630 – 800	22	14	8	2000 –	31	22	16
800 – 1000	23	16	9				

Unit: μm

Linear Guideways

PM series

1.6.11.2 Accuracy – height and width

Height tolerance H

Permissible absolute dimension variance of height H, measured between centre of the screw-on surface C and underside of rail A, with block in any position on the rail.

Width tolerance N

Permissible absolute dimension variance of width N, measured between centre of the screw-on surfaces D and B, with block in any position on the rail.

Height variance of H

Permissible variance of height H between several blocks on a rail, measured in the same rail position.

Width variance of N

Permissible variance of width N between several blocks on a rail, measured in the same rail position.

Table 1.98 Height and width tolerances of non-interchangeable models

Series/size	Accuracy class	Height tolerance of H	Width tolerance of N	Height variance of H	Width variance of N
PMN05 – PMN12	Normal (C)	± 0,04	± 0,04	0,03	0,03
	High (H)	± 0,02	± 0,025	0,015	0,02
	Precision (P)	± 0,01	± 0,015	0,007	0,01

Unit: mm

Table 1.99 Height and width tolerances of interchangeable types

Series/size	Accuracy class	Height tolerance of H	Width tolerance of N	Height variance of H	Width variance of N	Height variance of H ¹⁾
PMN05 – PMN12	Normal (N)	± 0,04	± 0,04	0,03	0,03	0,07
	High (H)	± 0,02	± 0,025	0,015	0,02	0,04
	Precision (P)	± 0,01	± 0,015	0,007	0,01	0,02

Unit: mm

¹⁾ Permissible deviation of height H between several blocks on a pair of rails

1.6.12 Permissible mounting surface tolerances

Once the requirements relating to the accuracy of the mounting surfaces are met, the good accuracy, rigidity and lifetime of the PM series linear guideways are achieved.

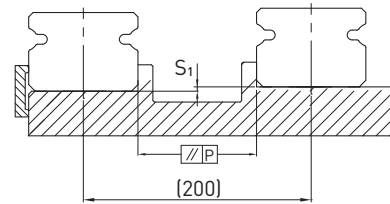

Parallelism of the reference surface (P)

Table 1.100 Maximum tolerance for parallelism (P)

Series/size	Preload class		
	ZF	Z0	Z1
PM_05	2	2	2
PM_09	4	4	3
PM_12	9	9	5

Unit: µm

Table 1.101 Maximum tolerance for height of reference surface (S₁)

Series/size	Preload class		
	ZF	Z0	Z1
PM_05	20	20	2
PM_09	35	35	6
PM_12	50	50	12

Unit: μm

Table 1.102 Requirements for the mounting surface

Series/size	Required evenness of the mounting surface
PM_05	0,015/200
PM_09	0,035/200
PM_12	0,050/200

Unit: mm

Note: The values in the table are applicable to the preload classes ZF and Z0. For Z1 or if more than one rail is to be mounted on the same surface, the table values must be at least halved.

1.6.13 Shoulder heights and fillets

Imprecise shoulder heights and fillets of mounting surfaces compromise precision and may lead to conflicts with the block or rail profiles. The following shoulder heights and edge profiles must be observed in order to avoid assembly problems.

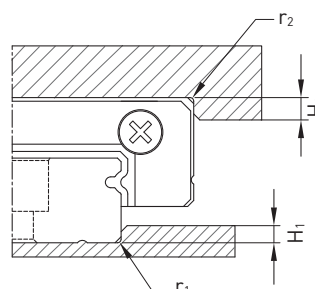

Table 1.103 Shoulder heights and fillets

Series/size	Max. edge radius r_1	Max. edge radius r_2	Shoulder height of H_1	Shoulder height of H_2
PMN05	0,1	0,2	1,2	2
PMN09	0,2	0,3	1,7	3
PMN12	0,3	0,4	1,7	4

Unit: mm

Linear Guideways

RG/QR series

1.7 Linear Guideway Series RG and QR

1.7.1 Properties of the linear guideways, series RG and QR

The HIWIN linear guideways of the RG series use rollers rather than balls as rolling elements. The RG series provides extremely good rigidity and very good loading capacity. It is designed with a 45° contact angle. Its linear contact surface greatly reduces deformation from the loading produced and therefore ensures very good rigidity and loading capacity in all 4 loading directions. The linear guides of the RG series are therefore ideal for use in high-precision manufacturing.

1.7.2 Structure of the RG/QR series

- 4-row recirculation roller bearing guide
- 45° contact angle
- Ball retainers prevent the rollers from falling out when the block is removed
- Various sealing variants depending on the field of application
- 6 options for connecting grease nipple and lubrication adapter
- SynchMotion™ technology (QR series)

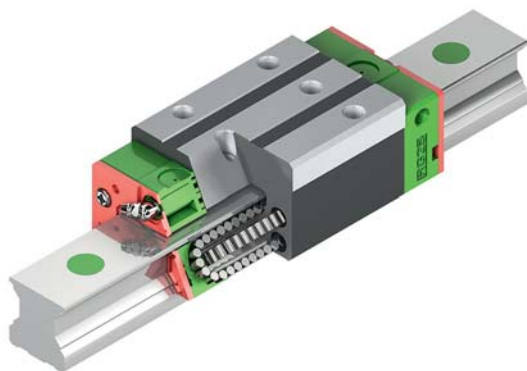

Fig. Structure of the RG series

1.7.3 Advantages

- Zero play
- Interchangeable
- Very high load ratings
- Very high rigidity
- Low displacement forces even with high preload

1.7.4 Article numbers of the RG/QR series

For RG/QR linear guideways, a distinction is made between interchangeable and non-interchangeable models. The dimensions of both models are the same. The main difference is that the block and rail in the interchangeable models can be freely interchanged. The article numbers of the series include the dimensions, model, accuracy class, preload etc.

The models of the QR series with SynchMotion™ technology offer all the positive properties of the standard series RG. Controlled movement of the rollers at a defined distance also results in improved synchronous performance, higher reliable travel speeds, extended lubrication intervals and less running noise. Since the installation dimensions of the QR blocks are identical to those of the RG blocks, they are also fitted on the RGR standard rail and can therefore be interchanged with ease.

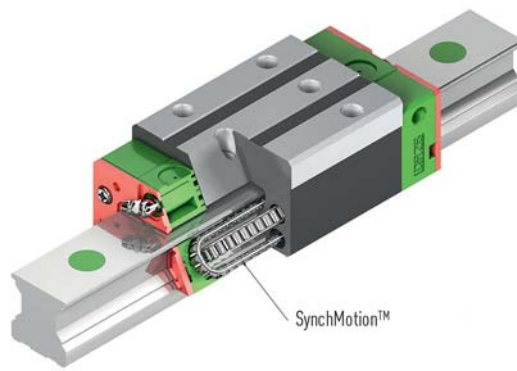

Fig. Structure of the QR series

Additional advantages of QR series

- Improved synchronous performance
- Optimized for higher travel speeds
- Extended lubrication intervals
- Less running noise

1.7.4.1 Non-interchangeable models (custom-assembled)

○ Article number of the fully assembled linear guideway

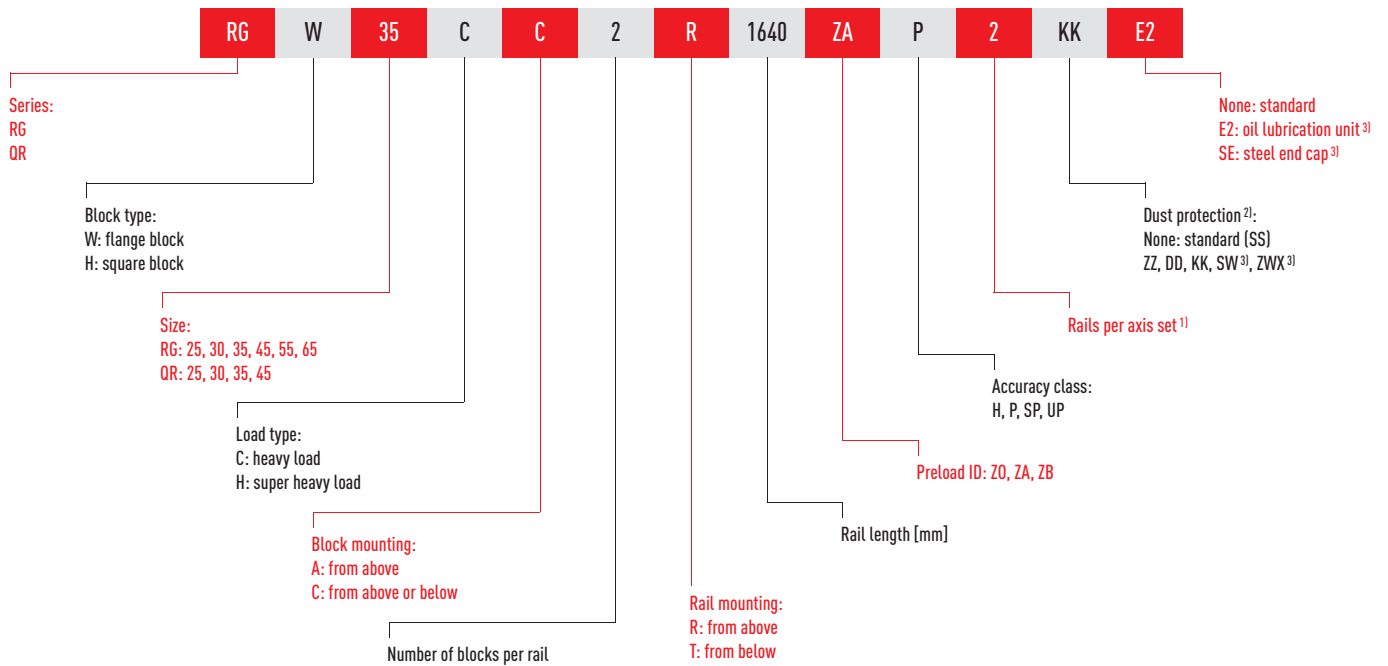

1.7.4.2 Interchangeable models

○ Article number of RG/QR block

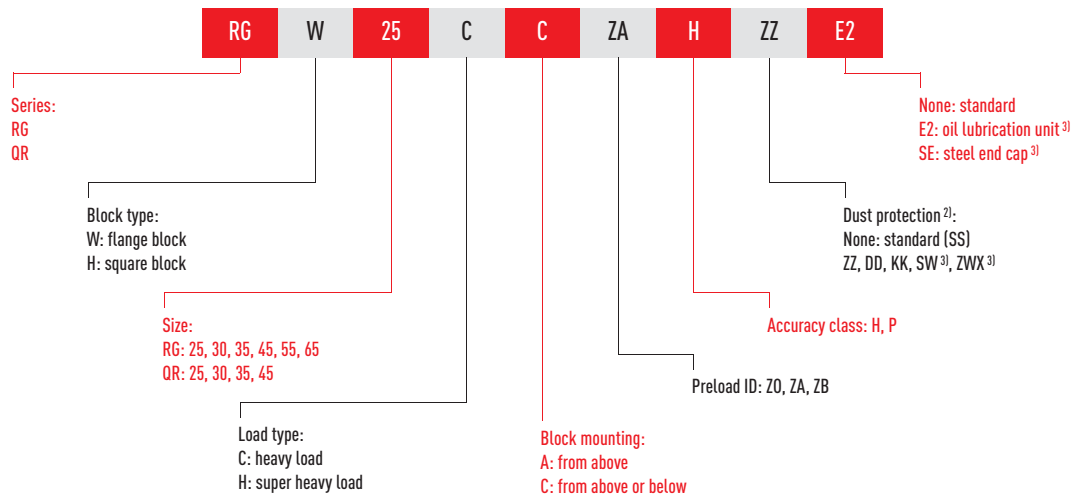

○ Article number of RG rail

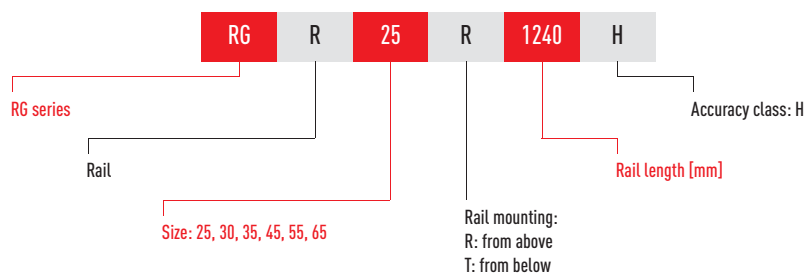

Note:

¹⁾ The figure 2 is also a quantity, i.e. one item of the above-mentioned article consists of a pair of rails. No number is specified for individual rails.

²⁾ You will find an overview of the individual sealing systems on page 89.

³⁾ Only available for RG

Linear Guideways

RG/QR series

1.7.5 Block types

HIWIN provides square and flange blocks for the linear guideways. Given their low height and large mounting surface, flange blocks are suited to large loads.

Table 1.104 Block types

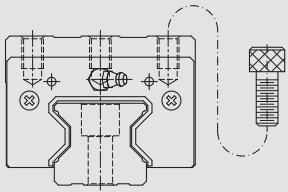
Type	Series/ size	Structure	Height [mm]	Rail length [mm]	Typical application
Square type	RGH-CA RGH-HA		40 – 90	100 – 4.000	<ul style="list-style-type: none"> ○ Automation technology ○ Transport technology ○ CNC machining centers ○ High-performance cutting machines ○ CNC grinding machines ○ Injection moulding machines ○ Portal milling machines ○ Machines and systems requiring high rigidity ○ Machines and systems requiring high load rating ○ Spark erosion machines

1.7.6 Preload

1.7.6.1 Definition

Every rail type can be preloaded. Oversized rollers are used for this purpose. Normally a linear guideway has negative clearance between track and rollers to increase rigidity and precision. The linear guideways of the RG/QR series offer three standard preloads for various applications and conditions.

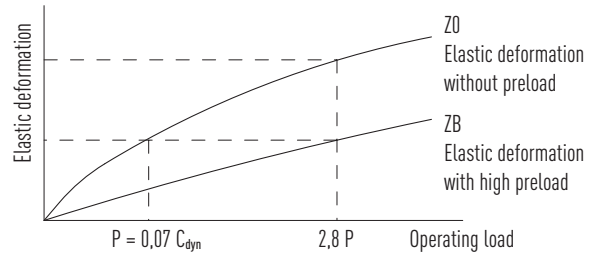

1.7.6.2 Preload ID

Table 1.105 Preload ID

ID	Preload		Application
Z0	Light preload	0,02 – 0,04 C_{dyn}	Constant load direction, little impact, low precision required
ZA	Medium preload	0,07 – 0,09 C_{dyn}	High precision needed
ZB	High preload	0,12 – 0,14 C_{dyn}	Very high rigidity required, with vibration and impact

Note:

Preload classes for interchangeable guides Z0, ZA. For non-interchangeable guides Z0, ZA, ZB.

The diagram shows the relationship between rigidity, frictional resistance and nominal lifetime. For smaller models, a preload of no more than ZA is recommended to avoid the lifetime being shortened as a result of preload.

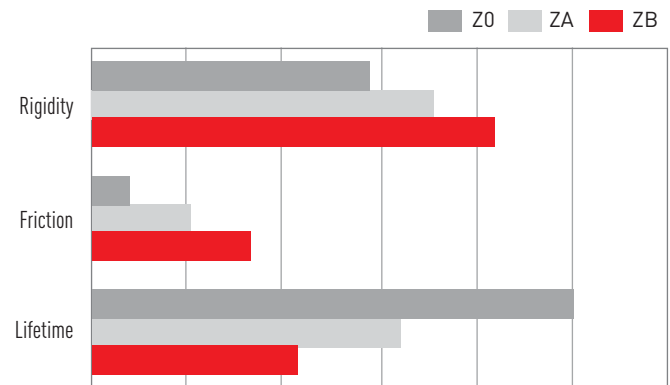

1.7.7 Load ratings and torques

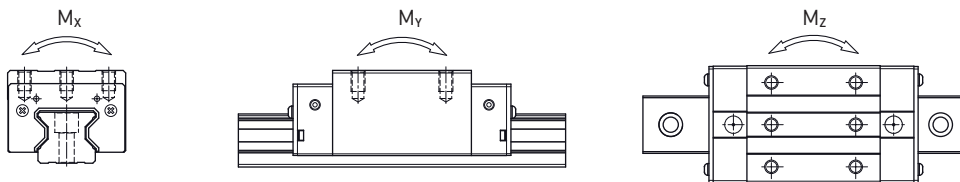

Table 1.106 Load ratings and torques for series RG/QR

Series/size	Dynamic load rating C_{dyn} [N]*	Static load rating C_0 [N]	Dynamic moment [Nm]			Static moment [Nm]		
			M_x	M_y	M_z	M_{0x}	M_{0y}	M_{0z}
RG_25C	27700	57100	367	293	293	758	605	605
QR_25C	38500	54400	511	444	444	722	627	627
RG_25H	33900	73400	450	457	457	975	991	991
QR_25H	44700	65300	594	621	621	867	907	907
RG_30C	39100	82100	688	504	504	1445	1060	1060
QR_30C	51500	73000	906	667	667	1284	945	945
RG_30H	48100	105000	845	784	784	1846	1712	1712
QR_30H	64700	95800	1138	1101	1101	1685	1630	1630
RG_35C	57900	105200	1194	792	792	2170	1440	1440
QR_35C	77000	94700	1590	1083	1083	1955	1331	1331
RG_35H	73100	142000	1508	1338	1338	2930	2600	2600
QR_35H	95700	126300	1975	1770	1770	2606	2335	2335
RG_45C	92600	178800	2340	1579	1579	4520	3050	3050
QR_45C	123200	156400	3119	2101	2101	3959	2666	2666
RG_45H	116000	230900	3180	2748	2748	6330	5470	5470
QR_45H	150800	208600	3816	3394	3394	5278	4694	4694
RG_55C	130500	252000	4148	2796	2796	8010	5400	5400
RG_55H	167800	348000	5376	4942	4942	11150	10250	10250
RG_65C	213000	411600	8383	5997	5997	16200	11590	11590
RG_65H	275300	572700	10839	10657	10657	22550	22170	22170

* Dynamic load rating for travel distance of 100 000 m

Linear Guideways

RG/QR series

1.7.8 Rigidity

Rigidity depends on preload. The adjacent formula can be used to determine deformation depending on rigidity.

$$\delta = \frac{P}{k}$$

δ : Deformation [μm]

P: Operating load [N]

k: Rigidity [N/ μm]

Table 1.107 Radial rigidity for series RG/QR

Load class	Series/ size	Preload		
		Z0	ZA	ZB
Heavy load	RG_25C	682	717	740
	QR_25C	616	645	665
	RG_30C	809	849	876
	QR_30C	694	726	748
	RG_35C	954	1002	1035
	QR_35C	817	856	882
	RG_45C	1433	1505	1554
	QR_45C	1250	1310	1350
	RG_55C	1515	1591	1643
	RG_65C	2120	2227	2300
Super heavy load	RG_25H	873	917	947
	QR_25H	730	770	790
	RG_30H	1083	1136	1173
	QR_30H	910	950	980
	RG_35H	1280	1344	1388
	QR_35H	1090	1140	1170
	RG_45H	1845	1938	2002
	QR_45H	1590	1660	1720
	RG_55H	2079	2182	2254
	RG_65H	2931	3077	3178

Unit: N/ μm

1.7.9 Dimensions of the RG/QR blocks

1.7.9.1 RGH/QRH

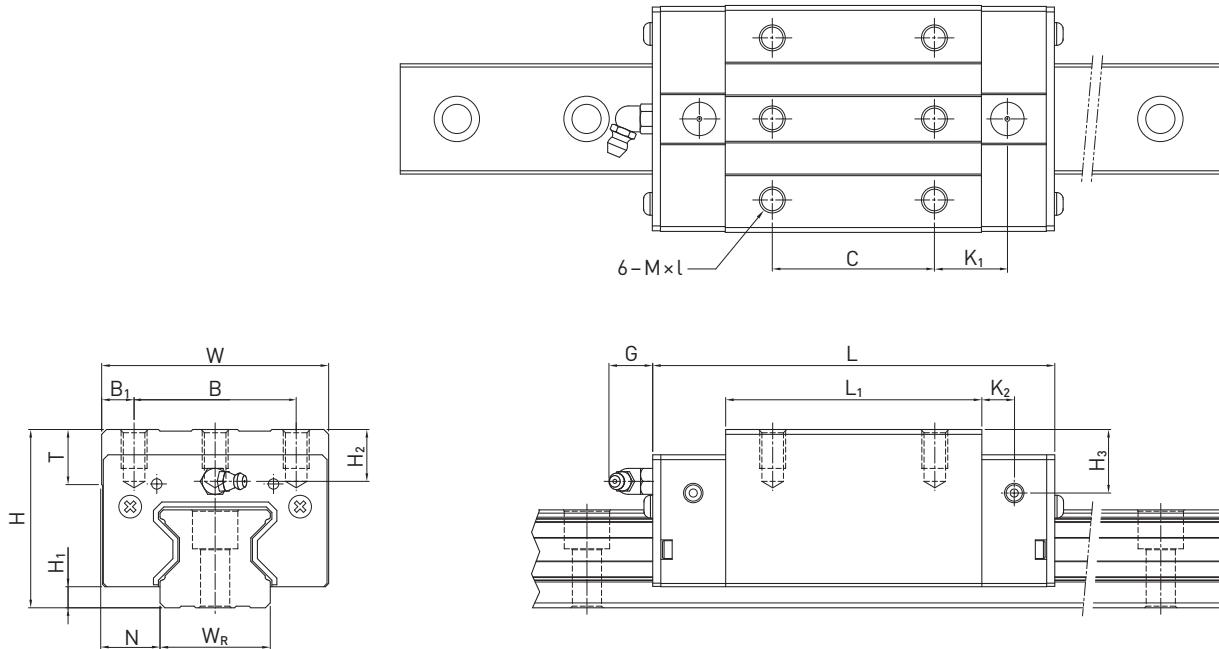

Table 1.108 Dimensions of the block

Series/ size	Installation dimensions [mm]			Dimensions of the block [mm]												Load Ratings [N]		Weight [kg]	
	H	H ₁	N	W	B	B ₁	C	L ₁	L	K ₁	K ₂	G	M × l	T	H ₂	H ₃	C _{dyn}		C ₀
RGH25CA	40	5,5	12,5	48	35,0	6,5	35	64,5	97,9	20,75	7,25	12,0	M6 × 8	9,5	10,20	10,0	27700	57100	0,61
RGH25HA							50	81,0	114,4	21,50							33900	73400	0,75
QRH25CA	40	5,5	12,5	48	35,0	6,5	35	66,0	97,9	20,75	7,25	12,0	M6 × 8	9,5	10,20	10,0	38500	54400	0,60
QRH25HA							50	81,0	112,9	21,50							44700	65300	0,74
RGH30CA	45	6,0	16,0	60	40,0	10,0	40	71,0	109,8	23,50	8,00	12,0	M8 × 10	9,5	9,50	10,3	39100	82100	0,90
RGH30HA							60	93,0	131,8	24,50							48100	105000	1,16
QRH30CA	45	6,0	16,0	60	40,0	10,0	40	71,0	109,8	23,50	8,00	12,0	M8 × 10	9,5	9,50	10,3	51500	73000	0,89
QRH30HA							60	93,0	131,8	24,50							64700	95800	1,15
RGH35CA	55	6,5	18,0	70	50,0	10,0	50	79,0	124,0	22,50	10,00	12,0	M8 × 12	12,0	16,00	19,6	57900	105200	1,57
RGH35HA							72	106,5	151,5	25,25							73100	142000	2,06
QRH35CA	55	6,5	18,0	70	50,0	10,0	50	79,0	124,0	22,50	10,00	12,0	M8 × 12	12,0	16,00	19,6	77000	94700	1,56
QRH35HA							72	106,5	151,5	25,25							95700	126300	2,04
RGH45CA	70	8,0	20,5	86	60,0	13,0	60	106,0	153,2	31,00	10,00	12,9	M10 × 17	16,0	20,00	24,0	92600	178800	3,18
RGH45HA							80	139,8	187,0	37,90							116000	230900	4,13
QRH45CA	70	8,0	20,5	86	60,0	13,0	60	106,0	153,2	31,00	10,00	12,9	M10 × 17	16,0	20,00	24,0	123200	156400	3,16
QRH45HA							80	139,8	187,0	37,90							150800	208600	4,10
RGH55CA	80	10,0	23,5	100	75,0	12,5	75	125,5	183,7	37,75	12,50	12,9	M12 × 18	17,5	22,00	27,5	130500	252000	4,89
RGH55HA							95	173,8	232,0	51,90							167800	348000	6,68
RGH65CA	90	12,0	31,5	126	76,0	25,0	70	160,0	232,0	60,80	15,80	12,9	M16 × 20	25,0	15,00	15,0	213000	411600	8,89
RGH65HA							120	223,0	295,0	67,30							275300	572700	12,13

For dimensions of rail, see page 79, for standard and optional lubrication adapter, see page 86.

Linear Guideways

RG/QR series

1.7.9.2 RGW/QRW

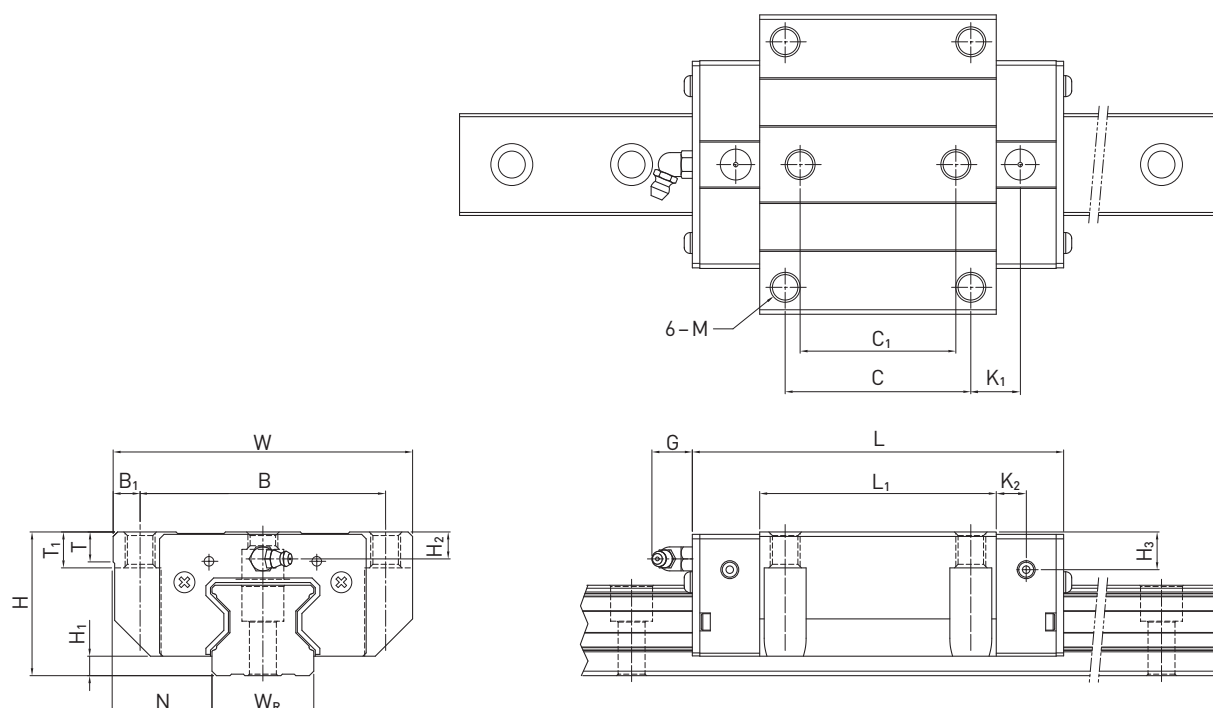

Table 1.109 Dimensions of the block

Series Size	Installation dimensions [mm]			Dimensions of the block [mm]													Load Ratings [N]		Weight [kg]		
	H	H ₁	N	W	B	B ₁	C	C ₁	L ₁	L	K ₁	K ₂	G	M	T	T ₁	H ₂	H ₃		C _{dyn}	C ₀
RGW25CC	36	5,5	23,5	70	57	6,5	45	40	64,5	97,9	15,75	7,25	12,0	M8	9,5	10	6,20	6,0	27700	57100	0,72
RGW25HC									81,0	114,4	24,00								33900	73400	0,91
QRW25CC	36	5,5	23,5	70	57	6,5	45	40	66,0	97,9	15,75	7,25	12,0	M8	9,5	10	6,20	6,0	38500	54400	0,71
QRW25HC									81,0	112,9	24,00								44700	65300	0,90
RGW30CC	42	6,0	31,0	90	72	9	52	44	71,0	109,8	17,50	8,00	12,0	M10	9,5	10	6,50	7,3	39100	82100	1,16
RGW30HC									93,0	131,8	28,50								48100	105000	1,52
QRW30CC	42	6,0	31,0	90	72	9	52	44	71,0	109,8	17,50	8,00	12,0	M10	9,5	10	6,50	7,3	51500	73000	1,15
QRW30HC									93,0	131,8	28,50								64700	95800	1,51
RGW35CC	48	6,5	33,0	100	82	9	62	52	79,0	124,0	16,50	10,00	12,0	M10	12,0	13	9,00	12,6	57900	105200	1,75
RGW35HC									106,5	151,5	30,25								73100	142000	2,40
QRW35CC	48	6,5	33,0	100	82	9	62	52	79,0	124,0	16,50	10,00	12,0	M10	12,0	13	9,00	12,6	77000	94700	1,74
QRW35HC									106,5	151,5	30,25								95700	126300	2,38
RGW45CC	60	8,0	37,5	120	100	10	80	60	106,0	153,2	21,00	10,00	12,9	M12	14,0	15	10,00	14,0	92600	178800	3,43
RGW45HC									139,8	187,0	37,90								116000	230900	4,57
QRW45CC	60	8,0	37,5	120	100	10	80	60	106,0	153,2	21,00	10,00	12,9	M12	14,0	15	10,00	14,0	123200	156400	3,41
QRW45HC									139,8	187,0	37,90								150800	208600	4,54
RGW55CC	70	10,0	43,5	140	116	12	95	70	125,5	183,7	27,75	12,50	12,9	M14	16,0	17	12,00	17,5	130500	252000	5,43
RGW55HC									173,8	232,0	51,90								167800	348000	7,61
RGW65CC	90	12,0	53,5	170	142	14	110	82	160,0	232,0	40,80	15,80	12,9	M16	22,0	23	15,00	15,0	213000	411600	11,63
RGW65HC									223,0	295,0	72,30								275300	572700	16,58

For dimensions of rail, see page 79, for standard and optional lubrication adapter, see page 86.

1.7.10 Dimensions of the RG rail

The RG rails are used for both the RG and QR blocks.

1.7.10.1 Dimensions of RGR_R

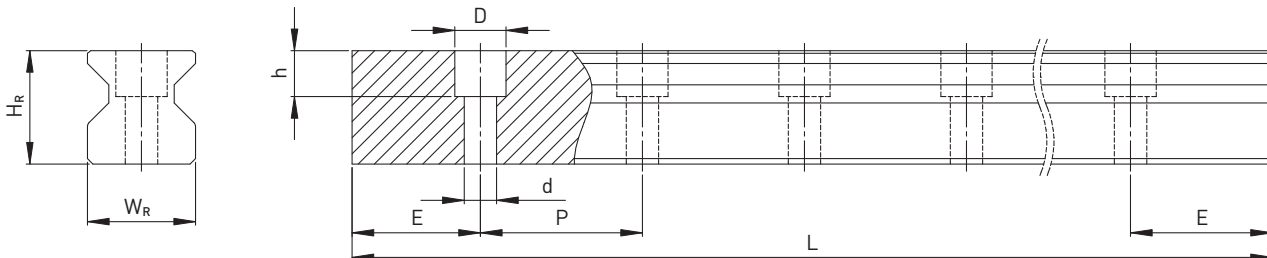

Table 1.110 Dimensions of rail RGR_R

Series/ size	Assembly screw for rail [mm]	Dimensions of rail [mm]						Max. length [mm]	Max. length $E_1 = E_2$	$E_{1/2}$ min [mm]	$E_{1/2}$ max [mm]	Weight [kg/m]
		W_R	H_R	D	h	d	P					
RGR25R	M6 × 20	23	23,6	11,0	9,0	7,0	30,0	4000	3960	8	22	3,08
RGR30R	M8 × 25	28	28,0	14,0	12,0	9,0	40,0	4000	3920	9	31	4,41
RGR35R	M8 × 25	34	30,2	14,0	12,0	9,0	40,0	4000	3920	9	31	6,06
RGR45R	M12 × 35	45	38,0	20,0	17,0	14,0	52,5	4000	3937,5	12	40,5	9,97
RGR55R	M14 × 45	53	44,0	23,0	20,0	16,0	60,0	4000	3900	14	46	13,98
RGR65R	M16 × 50	63	53,0	26,0	22,0	18,0	75,0	4000	3900	15	60	20,22

1.7.10.2 Dimensions RGR_T (rail mounting from below)

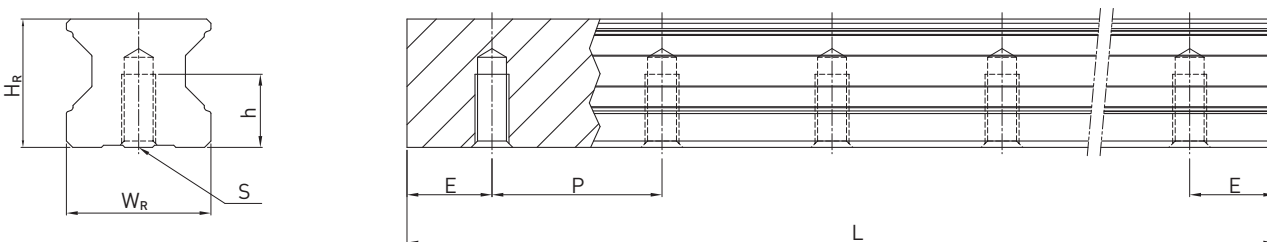

Table 1.111 Dimensions of rail RGR_T

Series/ size	Dimensions of rail [mm]					Max. length [mm]	Max. length $E_1 = E_2$	$E_{1/2}$ min [mm]	$E_{1/2}$ max [mm]	Weight [kg/m]
	W_R	H_R	S	h	P					
RGR25T	23	23,6	M6	12,0	30,0	4000	3960	8	22	3,36
RGR30T	28	28,0	M8	15,0	40,0	4000	3920	9	31	4,82
RGR35T	34	30,2	M8	17,0	40,0	4000	3920	9	31	6,48
RGR45T	45	38,0	M12	24,0	52,5	4000	3937,5	12	40,5	10,83
RGR55T	53	44,0	M14	24,0	60,0	4000	3900	14	46	15,15
RGR65T	63	53,0	M20	30,0	75,0	4000	3900	15	60	21,24

- Note:
1. The tolerance for E is $+0.5$ to -1 mm for standard rails and 0 to -0.3 mm for joints.
 2. If the $E_{1/2}$ dimensions are not indicated, the maximum possible number of mounting holes will be determined under consideration of $E_{1/2}$ min.
 3. The rails are shortened to the required length. If the $E_{1/2}$ dimensions are not indicated, these will be carried out symmetrically

Linear Guideways

RG/QR series

1.7.10.3 Calculating the length of rails

HIWIN offers rails in customized lengths. To prevent the risk of the end of the rail becoming unstable, the value E must not exceed half of the distance between the mounting holes (P). At the same time, the value $E_{1/2}$ should be between $E_{1/2}$ min and $E_{1/2}$ max so that the mounting hole does not rupture.

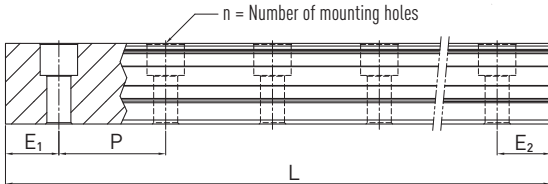

$$L = (n - 1) \cdot P + E_1 + E_2$$

- L: Total length of the rail [mm]
- n: Number of mounting holes
- P: Distance between two mounting holes [mm]
- $E_{1/2}$: Distance from the middle of the last mounting hole to the end of the rail [mm]

1.7.10.4 Tightening torques for mounting bolts

Insufficient tightening of the mounting bolts strongly compromises the precision of the linear guideway. The following tightening torques are recommended for the relevant screw sizes.

Table 1.113 Tightening torques of the mounting bolts according to ISO 4762-12.9

Series/size	Screw size	Torque [Nm]	Series/size	Screw size	Torque [Nm]
RG_25	M6 × 20	14	RG_45	M12 × 35	120
RG_30	M8 × 25	31	RG_55	M14 × 45	160
RG_35	M8 × 25	31	RG_65	M16 × 50	200

1.7.10.5 Cover caps for mounting holes of rails

The cover caps are used to keep the mounting holes free of chips and dirt. The standard plastic caps are provided with each rail. Optional cover caps must be ordered separately.

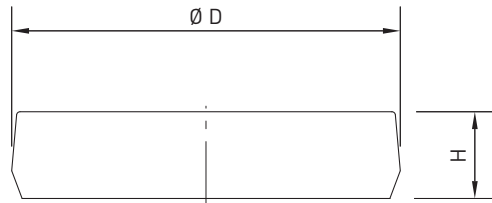

Table 1.114 Cover caps for mounting holes of rails

Rail	Screw	Article number			Ø D [mm]	Height H [mm]
		Plastic	Brass	Steel		
RGR25R	M6	C6	C6-M	C6-ST	11	2,5
RGR30R	M8	C8	C8-M	C8-ST	14	3,3
RGR35R	M8	C8	C8-M	C8-ST	14	3,3
RGR45R	M12	C12	C12-M	C12-ST	20	4,6
RGR55R	M14	C14	C14-M	C14-ST	23	5,5
RGR65R	M16	C16	C16-M	C16-ST	26	5,5

1.7.11 Sealing systems

Various sealing systems are available for HIWIN blocks. You will find an overview on page 89. The table below shows the total length of the blocks with the different sealing systems. Sealing systems suitable for these sizes are available.

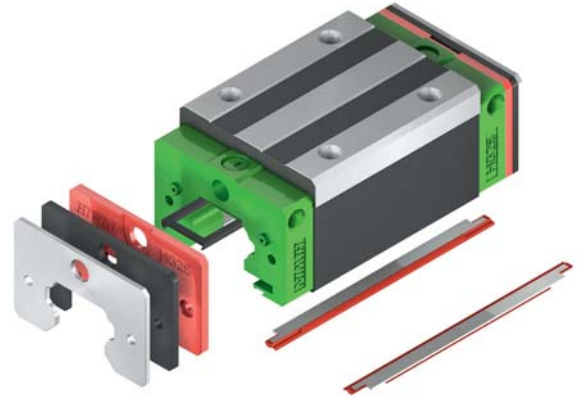

Table 1.115 Total length of block with different sealing systems

Series/ size	Total length L					
	SS	DD	ZZ	KK	SW	ZWX
RG_25C	97,9	102,3	99,9	104,3	—	—
QR_25C	97,7	102,3	99,9	104,3	—	—
RG_25H	114,4	118,8	116,4	120,8	—	—
QR_25H	112,9	117,3	114,9	119,3	—	—
RG_30C	109,8	114,6	112,8	117,6	—	—
QR_30C	109,8	114,6	112,8	117,6	—	—
RG_30H	131,8	136,6	134,8	139,6	—	—
QR_30H	131,8	136,6	134,8	139,6	—	—
RG_35C	124,0	129,0	127,0	132,0	—	—
QR_35C	124,0	129,0	127,0	132,0	—	—
RG_35H	151,5	156,5	154,5	159,5	—	—
QR_35H	151,5	156,5	154,5	159,5	—	—
RG_45C	153,2	160,4	156,2	163,4	156,5	166,2
QR_45C	153,2	160,4	156,2	163,4	—	—
RG_45H	187,0	194,2	190,0	197,2	190,3	200,0
QR_45H	187,0	194,2	190,0	197,2	—	—
RG_55C	183,7	190,9	186,7	193,9	186,9	198,3
RG_55H	232,0	239,2	235,0	242,2	235,2	246,6
RG_65C	232,0	240,8	235,0	243,8	235,2	245,3
RG_65H	295,0	303,8	298,0	306,8	298,2	308,3

Unit: mm

1.7.11.1 Designation of seal sets

The sealing sets are always supplied along with the assembly material and include the parts needed in addition to the standard seal.

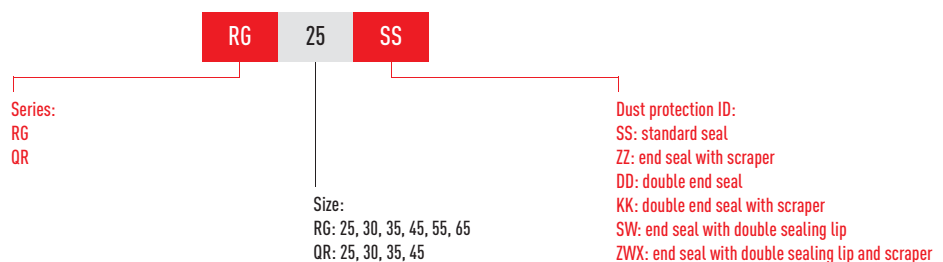

Linear Guideways

RG/QR series

1.7.11.2 Friction

The table shows the maximum frictional resistance of the individual end seal. Depending on sealing setup (SS, ZZ, DD, KK), the value may have to be multiplied. The values indicated apply to blocks on uncoated rails. Higher friction forces occur on coated rails.

Table 1.117 Frictional resistance of the single-lipped seals

Series/size	Friction force [N]	Series/size	Friction force [N]
RG/QR_25	2,8	RG/QR_45	4,2
RG/QR_30	3,3	RG_55	5,1
RG/QR_35	3,5	RG_65	6,7

1.7.12 Tolerances depending on accuracy class

The RG and QR series are available in four accuracy classes depending on parallelism between block and rail, height accuracy H and accuracy of width N. The choice of accuracy class is determined by the machine requirements.

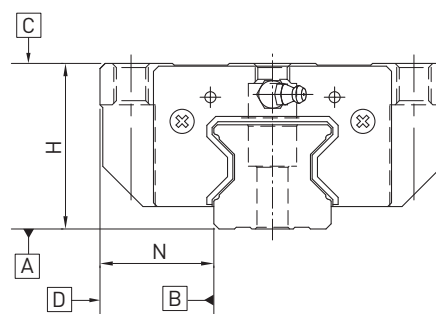

1.7.12.1 Parallelism

Parallelism of stop surfaces D and B of block and rail and parallelism of top of block C to mounting surface A of rail. Ideal linear guideway installation is required, as is a measurement in the centre of the block.

Table 1.118 Tolerance of parallelism between block and rail

Rail length [mm]	Accuracy class			
	H	P	SP	UP
- 100	7	3	2	2
100 - 200	9	4	2	2
200 - 300	10	5	3	2
300 - 500	12	6	3	2
500 - 700	13	7	4	2
700 - 900	15	8	5	3
900 - 1100	16	9	6	3
1100 - 1500	18	11	7	4
1500 - 1900	20	13	8	4
1900 - 2500	22	15	10	5
2500 - 3100	25	18	11	6
3100 - 3600	27	20	14	7
3600 - 4000	28	21	15	7

Unit: μm

1.7.12.2 Accuracy – height and width

Height tolerance H

Permissible absolute dimension variance of height H, measured between centre of screw-on surface C and underside of rail A, with block in any position on the rail.

Width tolerance N

Permissible absolute dimension variance of width N, measured between centre of screw-on surfaces D and B, with block in any position on the rail.

Height variance of H

Permissible variance of height H between several blocks on a rail, measured in the same rail position.

Width variance of N

Permissible variance of width N between several blocks on a rail, measured in the same rail position.

Table 1.119 Height and width tolerances of non-interchangeable models

Series/size	Accuracy class	Height tolerance of H	Width tolerance of N	Height variance of H	Width variance of N
RG_25, 30, 35 QR_25, 30, 35	High (H)	± 0,04	± 0,04	0,015	0,015
	Precision (P)	0 – 0,04	0 – 0,04	0,007	0,007
	Super precision (SP)	0 – 0,02	0 – 0,02	0,005	0,005
	Ultra precision (UP)	0 – 0,01	0 – 0,01	0,003	0,003
RG_45, 55 QR_45	High (H)	± 0,05	± 0,05	0,015	0,02
	Precision (P)	0 – 0,05	0 – 0,05	0,007	0,01
	Super precision (SP)	0 – 0,03	0 – 0,03	0,005	0,007
	Ultra precision (UP)	0 – 0,02	0 – 0,02	0,003	0,005
RG_65	High (H)	± 0,07	± 0,07	0,02	0,025
	Precision (P)	0 – 0,07	0 – 0,07	0,01	0,015
	Super precision (SP)	0 – 0,05	0 – 0,05	0,007	0,01
	Ultra precision (UP)	0 – 0,03	0 – 0,03	0,005	0,007

Unit: mm

Table 1.120 Height and width tolerances of interchangeable types

Series/size	Accuracy class	Height tolerance of H	Width tolerance of N	Height variance of H	Width variance of N
RG_25, 30, 35 QR_25, 30, 35	High (H)	± 0,04	± 0,04	0,015	0,015
	Precision (P)	± 0,02	± 0,02	0,007	0,007
RG_45, 55 QR_45	High (H)	± 0,05	± 0,05	0,015	0,02
	Precision (P)	± 0,025	± 0,025	0,007	0,01
RG_65	High (H)	± 0,07	± 0,07	0,02	0,025
	Precision (P)	± 0,035	± 0,035	0,01	0,015

Unit: mm

Linear Guideways

RG/QR series

1.7.13 Permissible mounting surface tolerances

Once the requirements relating to the accuracy of the mounting surfaces are met, the good accuracy, rigidity and lifetime of the RG and QR series linear guideways are achieved.

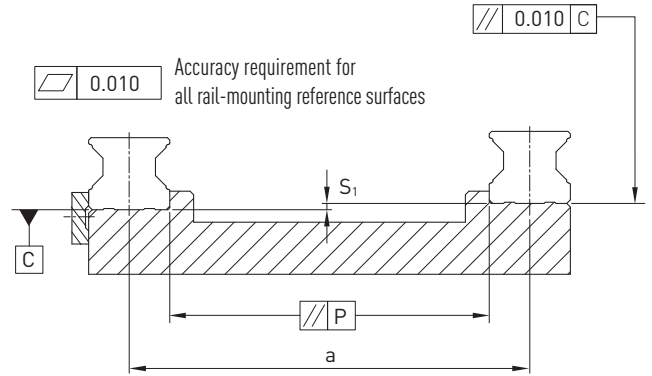

- Tolerance for the parallelism of the reference surface (P)

Table 1.121 Maximum tolerance for parallelism (P)

Series/size	Preload class		
	Z0	ZA	ZB
RG/QR_25	9	7	5
RG/QR_30	11	8	6
RG/QR_35	14	10	7
RG/QR_45	17	13	9
RG_55	21	14	11
RG_65	27	18	14

Unit: μm

- Tolerance for the height of the reference surface (S_1)

$$S_1 = a \times K$$

S_1 : Max. height tolerance
 a : Distance between rails
 K : Coefficient of the height tolerance

Table 1.122 Coefficient of height tolerance (K)

Series/size	Preload class		
	Z0	ZA	ZB
RG_25 – 65/QR_25 – 45	$2,2 \times 10^{-4}$	$1,7 \times 10^{-4}$	$1,2 \times 10^{-4}$

Height tolerance of the block mounting surface

- The height tolerance of the reference surface in the parallel use of two or more blocks (S_2)

$$S_2 = b \times 4.2 \times 10^{-5}$$

S_2 : Max. height tolerance
 b : Distance between blocks

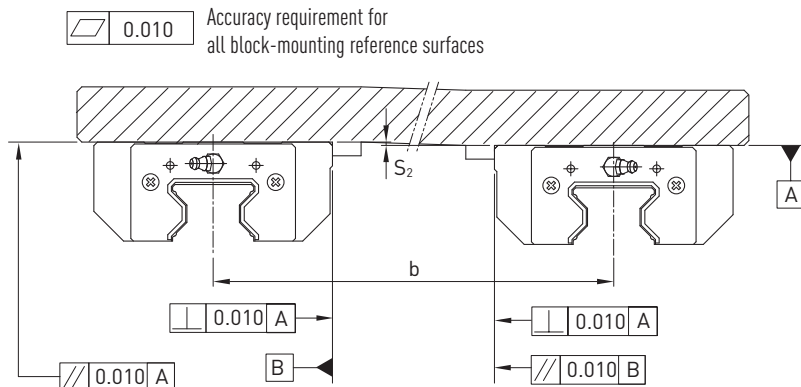

- The height tolerance of the reference surface in the parallel use of two or more blocks (S_3)

$$S_3 = c \times 4.2 \times 10^{-5}$$

S_3 : Max. height tolerance
 c : Distance between blocks

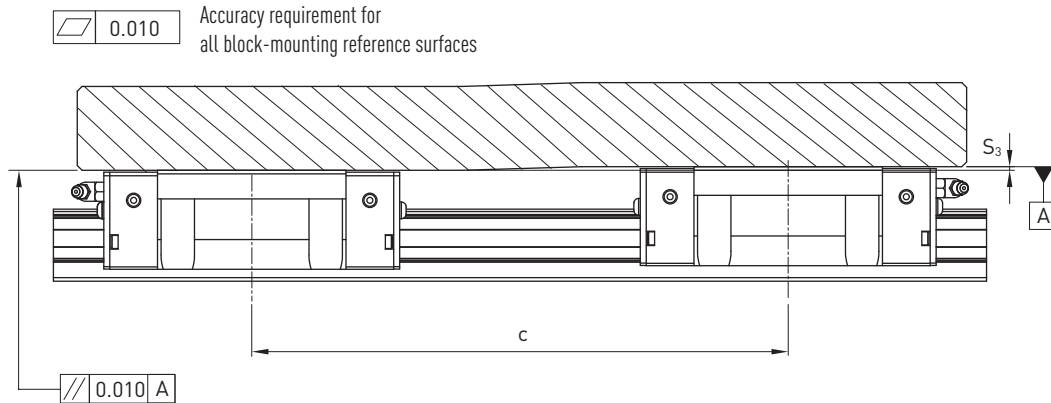

1.7.14 Shoulder heights and fillets

Imprecise shoulder heights and fillets of mounting surfaces compromise precision and may lead to conflicts with the block or rail profiles. The following shoulder heights and edge profiles must be observed in order to avoid assembly problems.

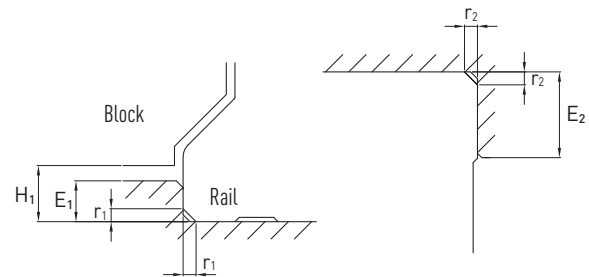

Table 1.123 Shoulder heights and fillets

Series/size	Max. edge radius r_1	Max. edge radius r_2	Shoulder height of reference edge of rail E_1	Shoulder height of reference edge of block E_2	Clearance under block H_1
RG/QR_25	1,0	1,0	5,0	5,0	5,5
RG/QR_30	1,0	1,0	5,0	5,0	6,0
RG/QR_35	1,0	1,0	6,0	6,0	6,5
RG/QR_45	1,0	1,0	7,0	8,0	8,0
RG/QR_55	1,5	1,5	9,0	10,0	10,0
RG/QR_65	1,5	1,5	10,0	10,0	12,0

Unit: mm

Linear Guideways

Accessories

1.8 Accessories

1.8.1 Lubrication adapters

A grease nipple is attached to one end of the block as standard. It can also be fitted on the side of the block. If fitted on the side, the grease nipple should not be fitted on the reference side. Lubrication can also be via a lubrication line connection.

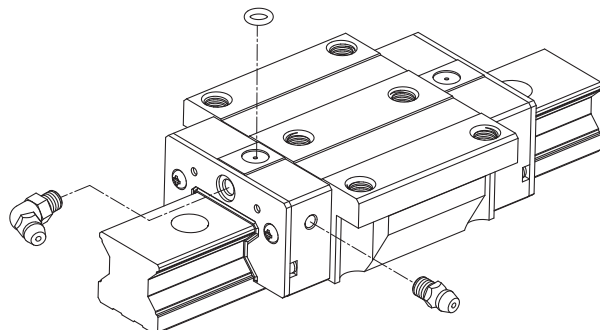

Table 1.124 Grease nipples

<p>M3 x 0,5P</p>	<p>M4 x 0,7P</p>	<p>M6 x 0,75P</p>
<p>Art.No.: 34310006 MG15, WE17 (standard)</p>	<p>Art.No.: 34310002 HG15, QH15, EG15, QE15 (standard)</p>	<p>Art.No.: 34320001 HG20–HG35, QH20–QH35, EG20–EG35, QE20–QE35, WE21–WE35, RG25–RG35 (standard)</p>
<p>M6 x 0,75P</p>	<p>PT 1/8</p>	<p>PT 1/8</p>
<p>Art.No.: 34310003 HG20–HG35, QH20–QH35, EG20–EG35, QE20–QE35, WE21–WE35, RG25–RG35 (option)</p>	<p>Art.No.: 34320003 HG45–HG65, QH45, RG45–RG65 (standard)</p>	<p>Art.No.: 3431000B HG45–HG65, QH45, RG45–RG65 (option)</p>

The stated article numbers apply to the standard dust protection. Article numbers for optional dust protection available on request.

Table 1.125 Lubrication fittings

<p>SF-76 Art.No.: 970001A1 HG20-HG35, QH20-QH35, EG20-EG35, QE20-QE35, WE21-WE35, RG25-RG35</p>	<p>SF-78 Art.No.: 970005A1 HG45-HG65, QH45, RG45-RG65</p>	<p>SF-86 Art.No.: 970003A1 HG20-HG35, QH20-QH35, EG20-EG35, QE20-QE35, WE21-WE35, RG25-RG35</p>
<p>SF-88 Art.No.: 970007A1 HG45-HG65, QH45, RG45-RG65</p>	<p>LF-64 Art.No.: 97000EA1 HG15, QH15, EG15, QE15</p>	<p>LF-76 Art.No.: 970002A1 HG20-HG35, QH20-QH35, EG20-EG35, QE20-QE35, WE21-WE35, RG25-RG35</p>
<p>LF-78 Art.No.: 970006A1 HG45-HG65, QH45, RG45-RG65</p>	<p>LF-86 Art.No.: 970004A1 HG20-HG35, QH20-QH35, EG20-EG35, QE20-QE35, WE21-WE35, RG25-RG35</p>	<p>LF-88 Art.No.: 970008A1 HG45-HG65, QH45, RG45-RG65</p>

The stated article numbers apply to the standard dust protection. Article numbers for optional dust protection available on request.

Linear Guideways

Accessories

Table 1.126 Push-in fittings

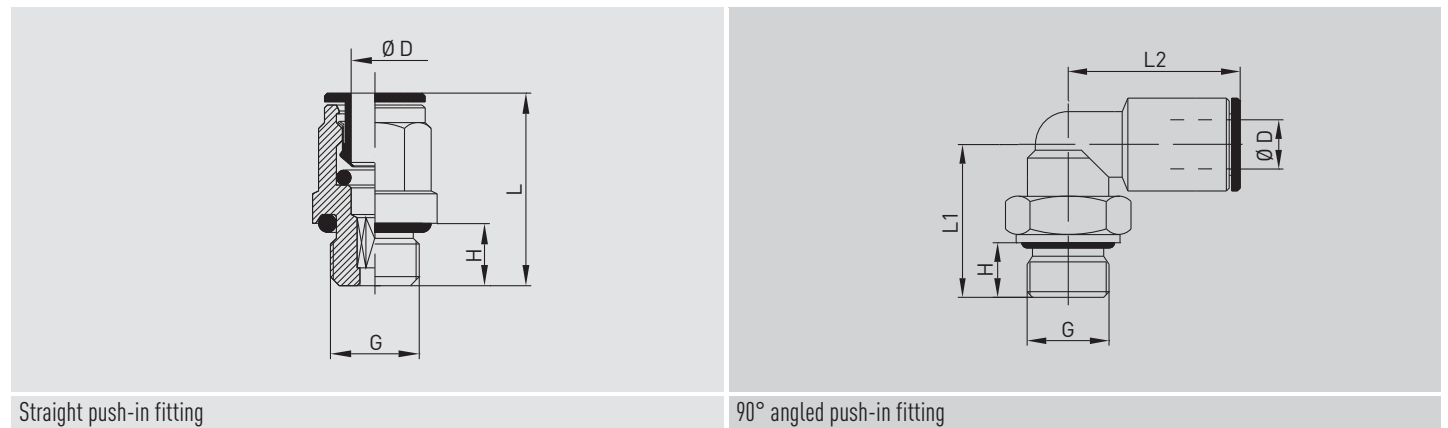

Table 1.127 Dimensions of push-in fittings

Article number	$\varnothing D$	G	Shape	H	L	L1	L2
8-12-0127	4	M6 \times 0,75	Straight	5	23,5	—	—
8-12-0131	4	G 1/8	Straight	6	20,0	—	—
8-12-0136	6	G 1/8	Straight	6	24,0	—	—
8-12-0128	4	M6 \times 0,75	Angled	5	—	15,5	18,0
8-12-0138	6	M6 \times 0,75	Angled	5	—	15,5	20,0
8-12-0130	4	G 1/8	Angled	6	—	20,0	20,0
8-12-0137	6	G 1/8	Angled	6	—	20,0	21,0

The stated article numbers apply to the standard dust protection. Article numbers for optional dust protection available on request.

1.8.2 Sealing systems SS, ZZ, DD, KK

The HIWIN end seals firstly prevent the ingress of foreign substances such as dust particles, chips or liquid into the block's ball tracks and secondly reduce the amount of lubricant lost. HIWIN provides various sealing systems for the various ambient condi-

tions of your application. The effectiveness of the end seal impacts directly on the lifetime of the linear guideway and should therefore be taken into account at the design stage and selected to suit the ambient conditions of your application.

SS (standard):

End seal with bottom seal

- For applications with little dirt and dust
- Only minimal increase in displacement forces

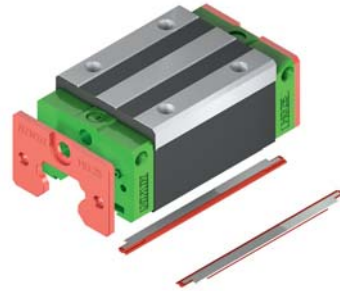

ZZ:

End seal with bottom seal and scraper

- For applications associated with hot chips or sharp-edged particles of dirt
- The scraper protects the end seal and prevents it from being damaged



DD:

Double end seal with bottom seal

- For applications associated with a lot of dirt and dust
- The double end seal effectively prevents the ingress of dirt into the block



KK:

Double end seal with bottom seal and scraper

- For applications associated with a lot of dirt and dust and hot chips or sharp-edged particles of dirt
- The scraper protects the end seals and prevents them from being damaged

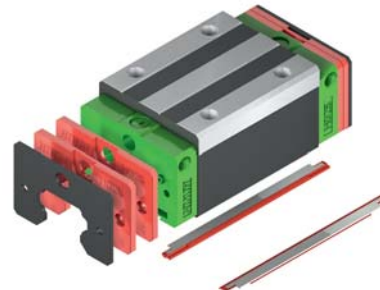

Availability of sealing systems SS, ZZ, DD and KK:

Sealing systems SS, ZZ, DD and KK are available for all series and sizes.

The exceptions are the MG and PM series, for which only the standard sealing system SS is available.

Linear Guideways

Accessories

1.8.3 Sealing systems SW and ZWX for optimum dust protection

Sealing systems SW and ZWX allow HIWIN linear guideways to also be used in areas with very high levels of dirt. The sealing systems offer optimum protection against

Properties:

- End seal with double sealing lip
- Optimized bottom seal
- Additional top seal
- Optimized stainless steel scraper

SW:

End seal with double sealing lip, optimized bottom seal and additional top seal

- Optimum dust protection
- The additional top seal prevents the ingress of dirt via the top of the rail
- The optimized bottom seal protects against the ingress of dirt on the rail flank

ZWX:

End seal with double sealing lip, optimized bottom seal, additional top seal and optimized scraper

- Optimum dust protection
- The additional top seal prevents the ingress of dirt via the top of the rail
- The optimized bottom seal protects against the ingress of dirt on the rail flank
- The optimized scraper also protects against dirt particles > 0.2 mm in diameter and prevents damage to the end seal.

the ingress of dirt, dust and liquid. The end seal is resistant to oils and greases and very resistant to wear.

Advantages:

- Optimum dust protection
- Lifetime extended ten-fold
- Longer lubrication intervals
- Lower maintenance costs

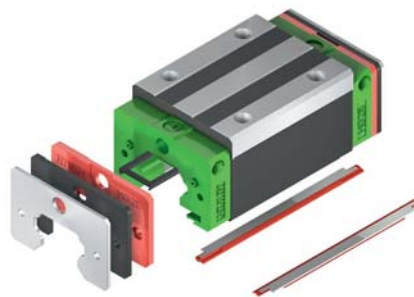
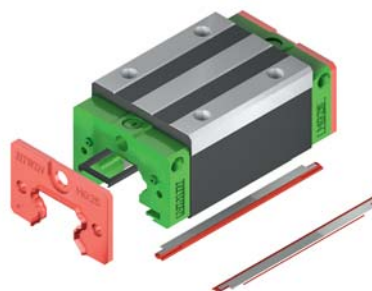

Dust test for sealing systems SW and ZWX

Thorough dust tests have shown that the lifetime with sealing systems SW and ZWX is ten times longer than that with a standard seal in cases of high dust levels.

Test conditions:

- Sealed room in which MDF dust is swirled about
- $v = 1.3 \text{ m/s}$
- Grease lubrication

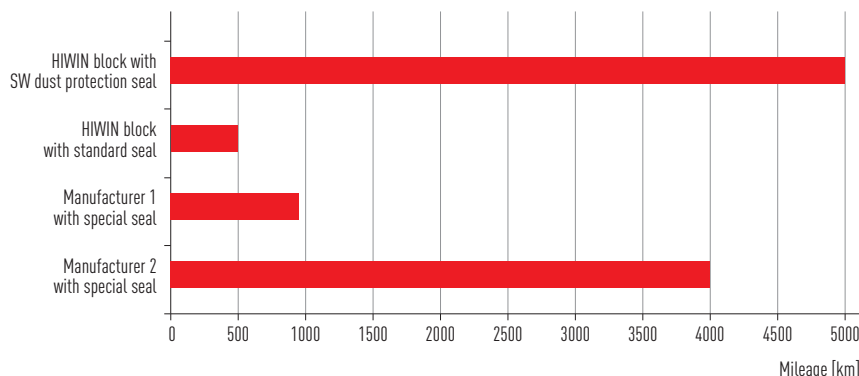

Table 1.128 Availability of sealing systems SW and ZWX

Series	Sizes							
	15	20	25	30	35	45	55	65
HG	○	●■	●■	●■	●■	●■	○□	○□
RG						○□	○□	○□

- Sealing system SW, ○ sealing system SW (without top seal and optimized bottom seal)
- Sealing system ZWX, □ sealing system ZWX (without top seal and optimized bottom seal)

2. Ballscrews

Ballscrews consist of a ballscrew shaft, a ballscrew nut into which the balls are integrated and the ball recirculation system. HIWIN ballscrews are distinguished by their low-friction and precise running, require little drive torque and offer good rigidity with smooth operation. HIWIN ballscrews are available in rolled, peeled and ground versions, making them the optimum product for any application. HIWIN has at its disposal state-of-the-art production facilities, highly qualified engineers and quality-assured manufacturing and assembly and only uses high-grade materials to meet all your requirements.

2.1 Product Overview



Rolled Ballscrews

Page 94

- Nut dimensions according to DIN 69051 Part 5
- Minimal axial backlash or free of play
- Nominal diameter 8 – 63 mm
- Standardized shaft ends



Peeled Ballscrews

Page 98

- Flange and cylindrical nuts
- Single and double nuts
- Nominal diameter 16 – 80 mm
- Standardized shaft ends



Accessories

Page 106

- Standard shaft ends
- Standard bearings
- Nut housing

Ballscrews

Product Overview

2.1.2 HIWIN ballscrews

HIWIN manufactures ballscrews in line with customer drawings or with HIWIN standard end machining. The following points must be defined and/or checked for the ballscrew definition. This ensures that the ballscrew is ideally adapted to the requirements in place.

1. Nominal diameter
2. Thread lead
3. Thread total length
4. End journal configuration
5. Ballscrew nut configuration
6. Accuracy grade (lead deviation, tolerances)
7. Operating speed
8. Maximum static load, operating load, preload friction torque
9. Safety requirements of ballscrew nut
10. Position of lubrication holes

2.1.3 HIWIN order code

In order to clearly identify the ballscrew, information about the ballscrew shaft and nut is needed.

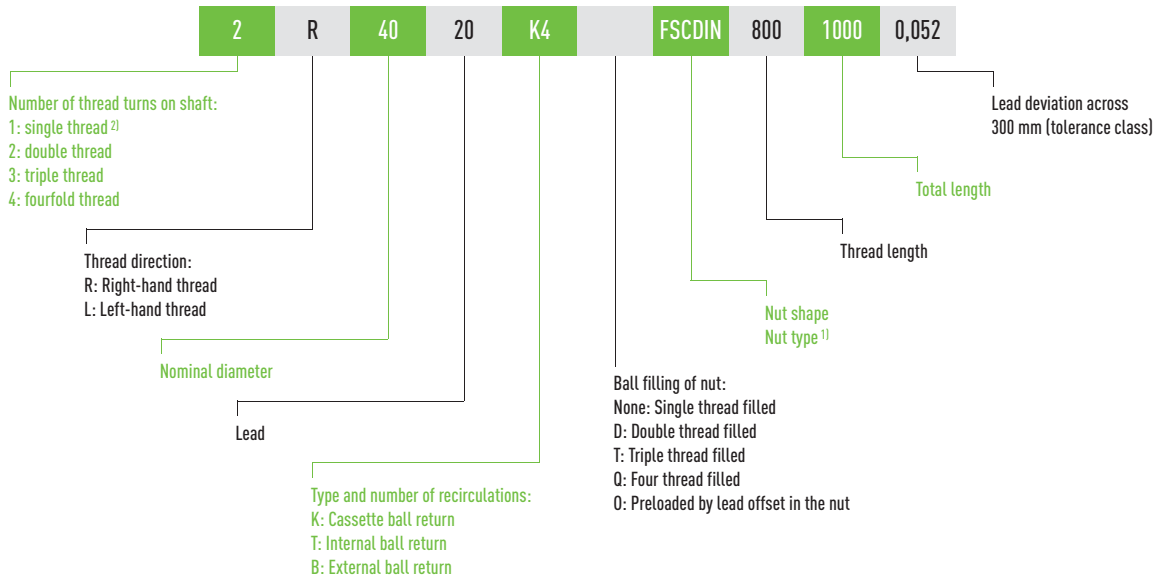

2.1.4 Details about the ballscrew shaft without the nut

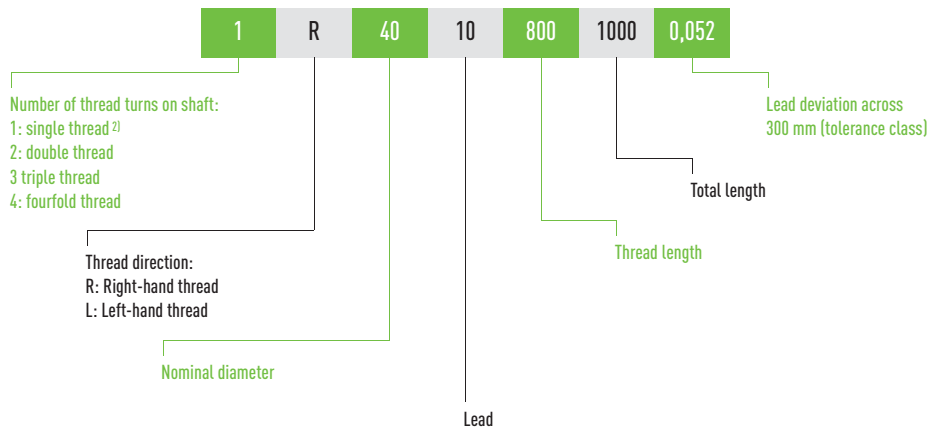

¹⁾ see table 2.1

²⁾ Standard – can be omitted with single-thread shafts

2.1.5 Details about the ballscrew nut without the shaft

The nut designations vary depending on whether a rolled, peeled or ground ballscrew is used.

Details of the ballscrew nut:

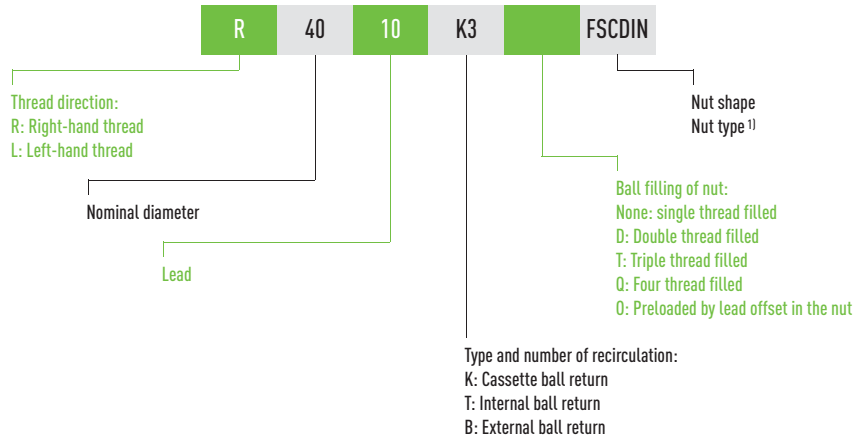

¹⁾ see Table 2.1

Table 2.1 Overview of nut designs

Nut designation	Description
DEB	Flange single nut according to DIN69051, Part 5 for peeled ballscrew shafts
DDB	Flange double nut according to DIN69051, Part 5 for peeled ballscrew shafts
FSIDIN FSCDIN	Flange single nut according to DIN69051, Part 5 for rolled and ground ballscrew shafts. The "DIN" addition is not used for customised flange nuts which do not correspond to DIN
RSI	Cylindrical single nut for rolled and ground ballscrew shafts
RSIT	Cylindrical single nut with screw-in thread for rolled ballscrew shafts
SE	Cylindrical single nut with screw-in thread for peeled ballscrew shafts
SEM	Flange single nut with integrated locking nut for peeled ballscrew shafts
ZE	Cylindrical single nut for peeled ballscrew shafts
ZD	Cylindrical double nut for peeled ballscrew shafts
FSV	Nut with reinforced recirculation system for heavy-duty operation

Ballscrews

Rolled Ballscrews

2.2 Rolled Ballscrews

2.2.1 Properties

One of the benefits of rolled ballscrews is that feed systems equipped with them have less friction and are quieter than standard threads.

HIWIN manufactures them using state-of-the-art rolling technologies where the processes of material selection, rolling, heat treatment, machining and assembly are very closely coordinated.

Rolled ballscrews from HIWIN can be flexibly used in virtually all areas of industry. Rolled ballscrew shafts with diameters of 8 mm to 63 mm are always kept in stock and can be supplied at short notice. They can be supplied with or without end machining. Complete bearing units combined with standardised shaft ends enable us to supply complete ballscrews.

2.2.2 Tolerance classes

Table 2.2 shows the tolerance classes of rolled ballscrews. The lead accuracy is defined using the deviation from nominal path over any 300 mm section of the entire length.

Table 2.2 Tolerance classes of rolled ballscrews

Path deviation	Tolerance class		
	T5	T7	T10
V_{300p}	0,023	0,052	0,21

Unit: mm

Limit deviation e_p $e_p = \pm \frac{L_u}{300} \cdot V_{300p}$ L_u Useful path
 V_{300p} Permissible path deviation over 300 mm travel

2.2.3 Overview of rolled ballscrews available

Table 2.3 Overview of rolled ballscrews available

Nominal diameter	Lead																		Max. spindle length
	1	1,25	2	2,5	3	4	5	5,08	6	8	10	12	16	20	25	32	40	50	
6	○	○																	500
8			○	●□	○														800
10			○	●□	○	○□	○												1500
12			○	●	○	●□	○	○				○	○		○				1500
15							○				○				○				1500
16			●	●		○	●□	●			●□		○□			○			3000
20				●		○	●□	●	○	○	○□			○□					3000
25						○	●□	●		○	●□				○□				4500
32						○	●□	●	○	○	○□			□	○	○□			4500
36							○	○	○	○					○				4500
40							●□	●	○	○	○□			□	○		○□		4500
50							○□		○		○□			□	○		○□	○	5600
63											●□				●		○		5600

Unit: mm

- Right-hand and left-hand thread
- Only right-hand thread
- Preferred type for right-hand thread with fast delivery

2.2.4 Nuts for rolled ballscrews

The ballscrews listed below are available ex stock in tolerance class T7 and therefore have a short delivery time.

Nut types deviating from the standard, double nuts for rolled ballscrews and deviating tolerance classes can be ordered and supplied. Contact HIWIN staff for more details.

2.2.4.1 Flange single nut FSCDIN/FSIDIN (DIN 69051 Part 5)

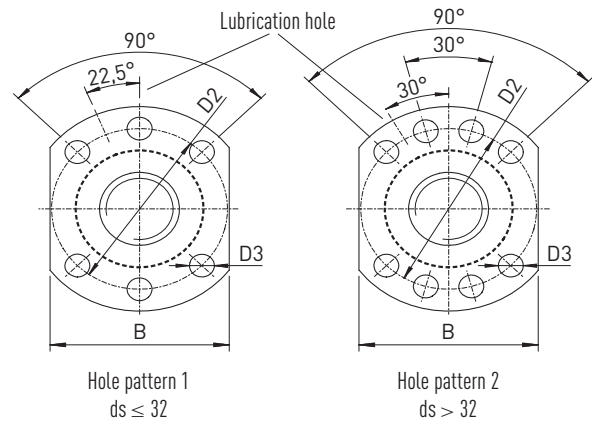
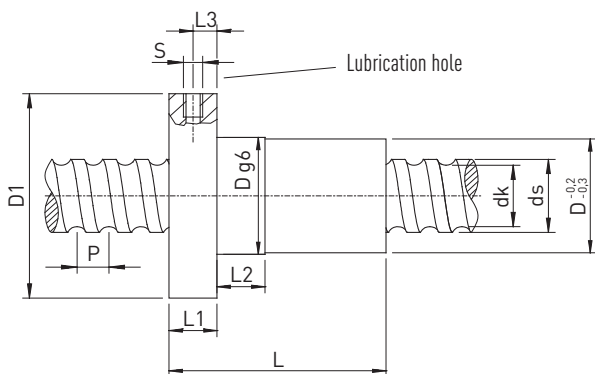

Table 2.4 Nut dimensions – Part 1

Article number	ds ±0,1	P	D g6	D1	D2	D3	Hole pattern	L	L1	L2	L3	S	B	dk	Dyn. Load C _{dyn} [N]	Stat. Load C ₀ [N]	Axial play max. [mm]	Mass [kg/pc.]
R15-05K4-FSCDIN	13,8	5	28	48	38	5,5	1	38	10	10	5	M6	40	11,8	12600	21000	0,04	0,18
R16-05T3-FSIDIN	15,5	5	28	48	38	5,5	1	40	10	10	5	M6	40	12,9	7320	12470	0,04	0,18
R16-10K3-FSCDIN	14,6	10	28	48	38	5,5	1	45	10	10	5	M6	40	12,5	9100	19300	0,04	0,20
R16-16K3-FSCDIN	14,4	16	28	48	38	5,5	1	61	12	20	6	M6	40	13,0	9100	19300	0,04	0,26
R20-05K4-FSCDIN	19,5	5	36	58	47	6,6	1	40	10	10	5	M6	44	16,9	13400	32740	0,04	0,28
R20-10K3-FSCDIN	19,3	10	36	58	47	6,6	1	48	10	10	5	M6	44	16,6	10000	23500	0,04	0,32
R20-20K2-FSCDIN	19,5	20	36	58	47	6,6	1	57	10	10	5	M6	44	17,1	6800	15300	0,04	0,37
R20-20K4-DFSCDIN	19,5	20	36	58	47	6,6	1	57	10	10	5	M6	44	17,1	12300	30500	0,04	0,36
R25-05K4-FSCDIN	24,9	5	40	62	51	6,6	1	43	10	12	5	M6	48	22,3	14900	41500	0,04	0,22
R25-10K4-FSCDIN	24,4	10	40	62	51	6,6	1	61	10	16	5	M6	48	21,8	16100	40400	0,04	0,43
R25-25K2-FSCDIN	24,7	25	40	62	51	6,6	1	70	10	16	5	M6	48	22,1	7400	19100	0,04	0,48
R25-25K4-DFSCDIN	24,7	25	40	62	51	6,6	1	70	10	16	5	M6	48	22,1	13500	38200	0,04	0,46
R32-05K6-FSCDIN	31,7	5	50	80	65	9,0	1	48	12	10	6	M6	62	29,1	23900	81900	0,04	0,59
R32-10K5-FSCDIN	31,8	10	50	80	65	9,0	1	77	12	16	6	M6	62	28,6	31500	80100	0,04	0,82
R32-20K3-FSCDIN	31,8	20	50	80	65	9,0	1	88	12	16	7	M6	62	28,6	17000	48500	0,04	0,91
R32-32K2-FSCDIN	31,9	32	50	80	65	9,0	1	88	12	20	6	M6	62	28,7	11600	31800	0,04	0,90
R32-32K4-DFSCDIN	31,9	32	80	80	65	9,0	1	88	12	12	6	M6	62	28,7	20600	62200	0,04	0,87
R40-05K6-FSCDIN	39,4	5	63	93	78	9,0	2	50	14	10	7	M8 × 1	70	36,8	25900	100600	0,04	0,93
R40-10K4-FSCDIN	37,8	10	63	93	78	9,0	2	70	14	16	7	M8 × 1	70	32,8	45000	123000	0,04	1,19
R40-20K3-FSCDIN	37,8	20	63	93	78	9,0	2	88	14	16	7	M8 × 1	70	32,8	34850	90000	0,07	1,43
R40-40K2-FSCDIN	37,8	40	63	93	78	9,0	2	102	14	16	7	M8 × 1	70	32,9	23000	58400	0,07	1,61
R40-40K4-DFSCDIN	37,8	40	63	93	78	9,0	2	102	14	16	7	M8 × 1	70	32,9	41500	115800	0,07	1,59

Ballscrews

Rolled Ballscrews

Table 2.4 Nut dimensions – Part 2

Article number	ds ±0,1	P	D g6	D1	D2	D3	Hole pattern	L	L1	L2	L3	S	B	dk	Dyn. Load C _{dyn} [N]	Stat. Load C ₀ [N]	Axial play max. [mm]	Mass [kg/pc.]
R50-05K6-FSCDIN	49,3	5	75	110	93	11,0	2	50	16	10	8	M8 × 1	85	46,8	28300	127200	0,07	1,32
R50-10K6-FSCDIN	47,9	10	75	110	93	11,0	2	90	16	20	8	M8 × 1	85	42,9	74500	250000	0,07	2,05
R50-20K5-FSCDIN	48	20	75	110	93	11,0	2	132	18	25	9	M8 × 1	85	42,9	67200	217500	0,07	2,89
R50-40K3-FSCDIN	50,3	40	75	110	93	11,0	2	149	18	45	9	M8 × 1	85	45,0	39000	123000	0,07	2,96
R50-40K6-DFSCDIN	50,3	40	75	110	93	11,0	2	149	18	45	9	M8 × 1	85	45,0	70300	242600	0,07	2,93
R63-10T6-FSIDIN	63,1	10	90	125	108	11,0	2	120	18	16	9	M8 × 1	95	58,0	61920	214090	0,07	3,30

- DIN nuts for rolled ballscrew shafts
- Connecting dimensions acc. to DIN 69051 Part 5
- Nuts with NBR wiper
- Flange single nuts
- Precision ground ball tracks
- Reduced axial play on request
- FSCDIN/FSIDIN: Nut filled on one turn
- DFSCDIN: Nut filled on two turns

Order example: **R** 25 **10** **K4** **FSCDIN** 650 **730** 0,052

2.2.4.2 Cylindrical single nut RSIT with screw-in thread

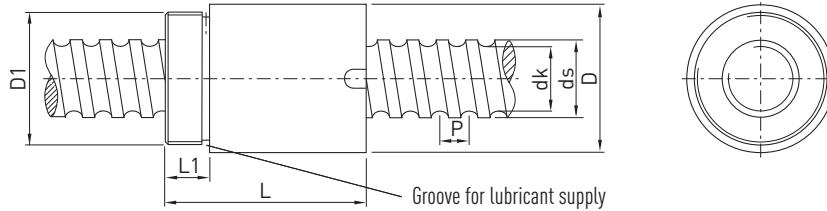

Table 2.5 Nut dimensions

Article number	ds ±0,1	P	D -0,2	D1	L -0,5	L1	dk	Dyn. Load C _{dyn} [N]	Stat. Load C ₀ [N]	Axial play max. [mm]	Mass [kg/pc.]
R08-02,5T2-RSIT	7,7	2,5	17,5	M15 × 1	27,5	7,5	6,1	1200	3360	0,04	0,03
R10-02,5T2-RSIT	9,3	2,5	19,5	M17 × 1	25,0	7,5	8,1	1780	2630	0,04	0,04
R10-04T2-RSIT	9,7	4	24,0	M22 × 1	32,0	10,0	7,7	1980	2820	0,04	0,08
R12-04B1-RSIT	11,9	4	25,5	M20 × 1	34,0	10,0	9,8	3000	5700	0,04	0,08

R10-02,5T2-RSIT and R10-04T2-RSIT without dirt wiper, R08-02,5T2-RSIT and R12-04B1-RSIT with polyamide dirt wiper on one side.

- Reduced axial play on request
- Nuts with dirt wipers
- Precision ground ball tracks

Order example: **R** 12 **4** **B1** **RSIT** 350 **405** 0,052

2.2.4.3 Cylindrical single nut RSI

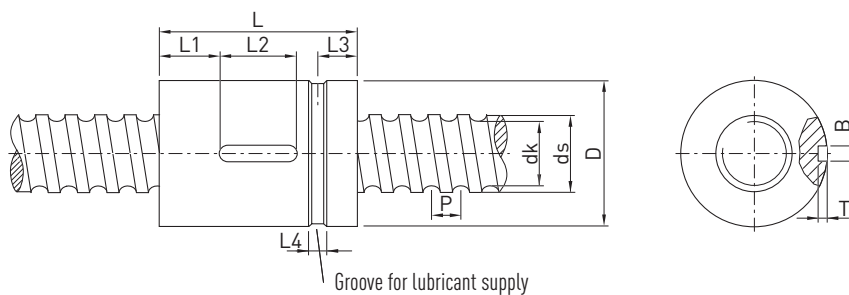

Table 2.6 Nut dimensions

Article number	ds ±0,1	P	D g7	L ±0,2	L1	L2	L3	L4	T +0,1	B P9	dk	Dyn. Load C _{dyn} [N]	Stat. Load C ₀ [N]	Axial play max. [mm]	Mass [kg/pc.]
R16-10T3-RSI	15,3	10	28	60	8	20	9,5	5	2,5	4	12,9	6100	10800	0,04	0,17
R20-10T3-RSI	19,8	10	34	60	20	20	12,0	4	2,0	5	17,5	8100	12600	0,04	0,35

- Reduced axial play on request
- Nuts with dirt wipers
- Precision ground ball tracks

Order example: **R** 16 **10** **T3** **RSI** 350 **405** 0,052

Ballscrews

Peeled Ballscrews

2.3 Peeled Ballscrews

2.3.1 Properties

In terms of quality, peeled ballscrews from HIWIN fall between rolled and ground ballscrews and can therefore be used for numerous transport or positioning applications. On request, we are happy to produce a lead measurement report for them. A number of nut shapes are available for peeled ballscrews, as both single and double nuts.

Customised complete ballscrews can be produced with short lead times. Complete bearing units combined with standardised shaft ends minimise the amount of design work involved.

2.3.2 Tolerance classes

Table 2.7 shows the tolerance classes of peeled ballscrews. The lead accuracy is defined using the deviation from nominal path over any 300 mm section of the entire length.

Table 2.7 Tolerance classes of peeled ballscrews

Path deviation	Tolerance class	
	T5	T7
V_{300p}	0,023	0,052

Unit: mm

Limit deviation e_p $e_p = \pm \frac{l_u}{300} \cdot V_{300p}$ l_u Useful path
 V_{300p} Permissible path deviation over 300 mm travel

2.3.3 Overview of peeled ballscrews available

Table 2.8 Overview of peeled ballscrews available

Nominal diameter	Lead				Max. spindle length ¹⁾
	5	10	20	40	
16	○□				3300
20	○□				5500
25	○□	○□			5500
32	○□	○□	○□		6500
40	○□	○□	○□	●	6500
50	○□	○□	○□		6500
63		○□	○□		6500
80		○□	○□		6500

Unit: mm

- Right-hand and left-hand thread
- Only right-hand thread
- Preferred type for right-hand thread with fast delivery

¹⁾ For longer ballscrews, please contact HIWIN. The critical speed and max. compressive force should be taken into account for long shafts.

2.3.4 Flange single nut DEB (DIN 69051 Part 5)

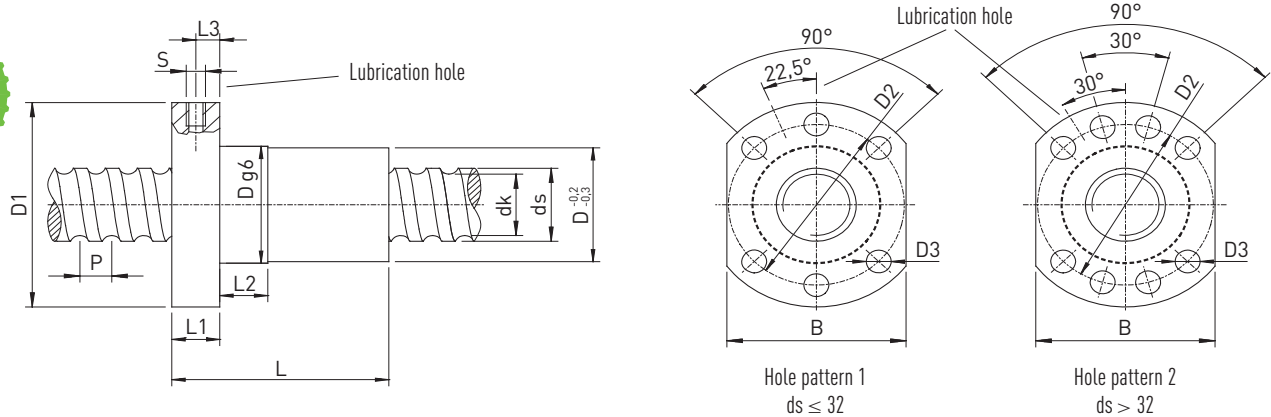

Table 2.9 Nut dimensions

Article number	ds h6	P	D g6	D1	D2	D3	L	L1	L2	L3	S	B	dk	Dyn. Load C _{dyn} [N]	Stat. Load C ₀ [N]	Axial play max. [mm]	Mass [kg/pc.]
R16-05T3-DEB	16	5	28	48	38	5,5	40	10	10	5,0	M6	40	13,5	9600	12700	0,02	0,15
R20-05T4-DEB	20	5	36	58	47	6,6	52	10	10	5,0	M6	44	17,5	13900	21800	0,02	0,29
R25-05T4-DEB	25	5	40	62	51	6,6	52	10	10	5,0	M6	48	22,5	15600	27900	0,02	0,31
R25-10T3-DEB	25	10	40	62	51	6,6	65	10	16	5,0	M6	48	21,0	24100	36200	0,02	0,36
R32-05T5-DEB	32	5	50	80	65	9,0	60	12	10	6,0	M6	62	29,5	20700	43900	0,02	0,62
R32-10T4-DEB	32	10	50	80	65	9,0	85	14	16	7,0	M6	62	27,8	40900	63200	0,02	0,69
R32-20T2-DEB	32	20	50	80	65	9,0	80	14	16	7,0	M6	62	27,8	20300	26800	0,02	0,66
R40-05T5-DEB	40	5	63	93	78	9,0	69	14	10	7,0	M8 × 1	70	37,5	22500	54600	0,02	1,04
R40-10T4-DEB	40	10	63	93	78	9,0	88	14	16	7,0	M8 × 1	70	35,8	46800	82600	0,02	1,13
R40-20T2-DEB	40	20	63	93	78	9,0	88	14	16	7,0	M8 × 1	70	35,8	23800	36400	0,03	1,14
R50-05T5-DEB	50	5	75	110	93	11,0	69	16	10	8,0	M8 × 1	85	47,5	24900	69800	0,02	1,44
R50-10T4-DEB	50	10	75	110	93	11,0	98	16	16	8,0	M8 × 1	85	45,8	52800	106800	0,02	1,62
R50-20T3-DEB	50	20	75	110	93	11,0	114	16	16	8,0	M8 × 1	85	45,8	40000	76200	0,03	1,92
R63-10T6-DEB	63	10	90	125	108	11,0	120	18	16	9,0	M8 × 1	95	58,8	84700	210800	0,04	2,73
R63-20T4-DEB	63	20	95	135	115	13,5	150	20	25	10,0	M8 × 1	100	55,4	105000	250000	0,04	4,00
R63-20T5-DEB	63	20	95	135	115	13,5	175	20	25	10,0	M8 × 1	100	55,4	125000	300000	0,04	4,50
R63-20K6-DEBH	63	20	125	165	145	13,5	170	25	25	12,0	M8 × 1	130	50,2	245700	783300	0,04	12,50
R80-10T6-DEB	80	10	105	145	125	13,5	120	20	16	10,0	M8 × 1	110	75,8	93400	269200	0,04	3,00
R80-20T4-DEB	80	20	125	165	145	13,5	160	25	25	12,0	M8 × 1	130	72,4	135000	322000	0,05	8,20
R80-20T5-DEB	80	20	125	165	145	13,5	175	25	25	12,0	M8 × 1	130	72,4	161500	398000	0,05	9,10
R80-20K6-DEBH	78	20	135	175	155	13,5	170	25	25	12,5	M8 × 1	140	68,2	280000	720000	0,05	11,50
R80-20K7-DEBH	78	20	135	175	155	13,5	190	25	25	12,5	M8 × 1	140	68,2	320000	820000	0,05	13,00

- Reduced axial play on request
- DIN nuts for peeled ballscrew shafts
- Connecting dimensions according to DIN 69051 Part 5
- Nuts with dirt wipers
- Precision ground ball tracks
- Left-handed nuts on request
- Nut-housing (page 115)

Order example: **R** **63** **10** **T6** **DEB** **3850** **3972** **0,052**

Ballscrews

Peeled Ballscrews

2.3.5 Flange double nut DDB (DIN 69051 Part 5)

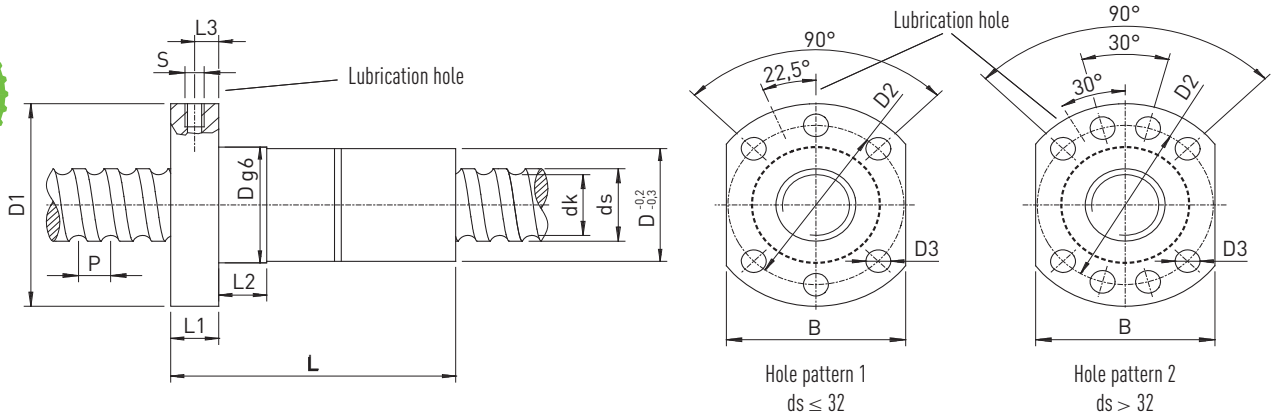

Table 2.10 Nut dimensions

Article number	ds h6	P	D g6	D1	D2	D3	L	L1	L2	L3	S	B	dk	Dyn. Load C _{dyn} [N]	Stat. Load C ₀ [N]	Mass [kg/pc.]
R16-05T3-DDB	16	5	28	48	38	5,5	80	10	10	5	M6	40	13,5	9600	12700	0,25
R20-05T4-DDB	20	5	36	58	47	6,6	82	10	10	5	M6	44	17,5	13900	21800	0,42
R25-05T4-DDB	25	5	40	62	51	6,6	95	10	10	5	M6	48	22,5	15600	27900	0,52
R25-10T3-DDB	25	10	40	62	51	6,6	115	10	16	5	M6	48	21,0	24100	36200	0,57
R32-05T5-DDB	32	5	50	80	65	9,0	95	12	10	6	M6	62	29,5	20700	43900	0,88
R32-10T4-DDB	32	10	50	80	65	9,0	138	14	16	7	M6	62	27,8	40900	63200	1,01
R32-20T2-DDB	32	20	50	80	65	9,0	138	14	16	7	M6	62	27,8	20300	26800	1,02
R40-05T5-DDB	40	5	63	93	78	9,0	109	14	10	7	M8 × 1	70	37,5	22500	54600	1,54
R40-10T4-DDB	40	10	63	93	78	9,0	150	14	16	7	M8 × 1	70	35,8	46800	82600	1,80
R40-20T2-DDB	40	20	63	93	78	9,0	150	14	16	7	M8 × 1	70	35,8	23800	36400	1,82
R50-05T5-DDB	50	5	75	110	93	11,0	112	16	10	8	M8 × 1	85	47,5	24900	69800	2,15
R50-10T4-DDB	50	10	75	110	93	11,0	164	16	16	8	M8 × 1	85	45,8	52800	106800	2,52
R50-20T3-DDB	50	20	75	110	93	11,0	196	16	16	8	M8 × 1	85	45,8	40000	76200	3,14
R63-10T6-DDB	63	10	90	125	108	11,0	205	18	16	9	M8 × 1	95	58,8	84700	210800	4,19
R63-20T4-DDB	63	20	95	135	115	13,5	270	20	25	10	M8 × 1	100	55,4	105000	250000	6,70
R80-10T6-DDB	80	10	105	145	125	13,5	205	20	16	10	M8 × 1	110	75,8	93400	269200	4,74
R80-20T4-DDB	80	20	125	165	145	13,5	280	25	25	12	M8 × 1	130	72,4	135000	322000	13,80

- Reduced axial play on request
- DIN nuts for peeled ballscrew shafts
- Connecting dimensions according to DIN 69051 Part 5
- Nuts with dirt wipers
- Precision ground ball tracks
- Left-handed nuts on request
- Nut-housing (page 115)

Order example: **R** **63** **10** **T6** **DDB** **3850** **3972** **0,052**

2.3.6 Cylindrical single nut ZE

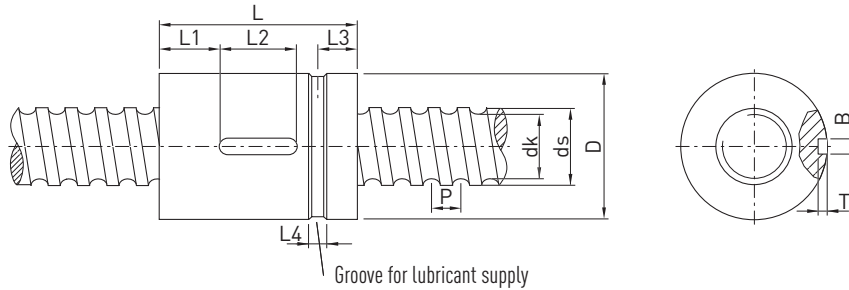

Table 2.11 Nut dimensions

Article number	ds h6	P	D g7	L ±0,2	L1	L2	L3	L4	T +0,1	B P9	dk	Dyn. Load C _{dyn} [N]	Stat. Load C ₀ [N]	Axial play max. [mm]	Mass [kg/pc.]
R16-05T3-ZE	16	5	28	40	12,0	16	9	4	2,4	4	13,5	9600	12700	0,02	0,10
R20-05T4-ZE	20	5	36	51	15,0	20	10	4	2,4	4	17,5	13900	21800	0,02	0,23
R25-05T4-ZE	25	5	40	60	20,0	20	12	5	2,4	4	22,5	15600	27900	0,02	0,29
R25-10T3-ZE	25	10	48	65	22,0	20	15	5	2,4	4	21,0	24100	36200	0,02	0,50
R32-05T5-ZE	32	5	48	60	20,0	20	12	5	2,4	4	29,5	20700	43900	0,02	0,38
R32-10T4-ZE	32	10	56	80	27,0	25	15	5	2,4	4	27,8	40900	63200	0,02	0,74
R32-20T2-ZE	32	20	56	80	27,0	25	15	5	2,4	4	27,8	20300	26800	0,02	0,70
R40-05T5-ZE	40	5	56	68	24,0	20	15	6	2,4	4	37,5	22500	54600	0,02	0,44
R40-10T4-ZE	40	10	62	88	31,0	25	15	6	2,4	4	35,8	46800	82600	0,02	0,85
R40-20T2-ZE	40	20	62	88	31,0	25	15	6	2,4	4	35,8	23800	36400	0,03	0,88
R50-05T5-ZE	50	5	68	69	24,0	20	15	6	2,4	4	47,5	24900	69800	0,02	0,72
R50-10T4-ZE	50	10	72	100	37,0	25	17	6	2,4	4	45,8	52800	106800	0,02	1,04
R50-20T3-ZE	50	20	72	114	44,0	25	17	6	2,4	4	45,8	40000	76200	0,03	1,10
R63-10T6-ZE	63	10	85	120	44,0	32	17	6	3,5	6	58,8	84700	210800	0,04	1,73
R63-20T4-ZE	63	20	95	135	52,0	32	17	6	3,5	6	55,4	105000	250000	0,04	3,80
R80-10T6-ZE	80	10	105	120	44,0	32	17	8	3,5	6	75,8	93400	269200	0,04	2,80
R80-20T4-ZE	80	20	125	150	52,0	45	17	8	3,5	6	72,4	135000	322000	0,05	7,80
R80-20T6-ZEH	78	20	130	182	68,5	45	19	8	4,0	0	68,2	200000	510000	0,05	11,05

- Reduced axial play on request
- Nuts with dirt wipers
- Precision ground ball tracks
- Left-handed nuts on request

Order example: **R** 16 **05** **T3** **ZE** 420 495 0,052

Ballscrews

Peeled Ballscrews

2.3.7 Cylindrical double nut ZD

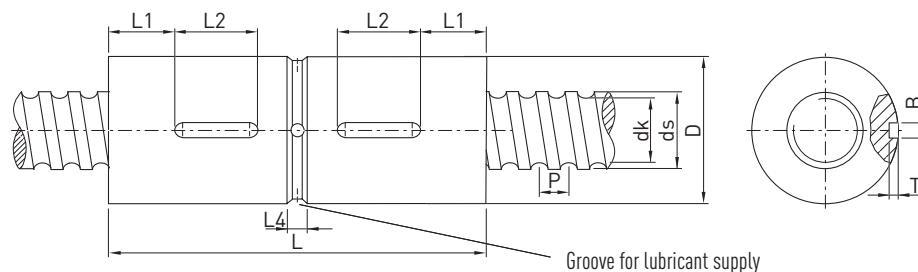

Table 2.12 Nut dimensions

Article number	ds h6	P	D g7	L	L1	L2	L4	T +0,1	B P9	dk	Dyn. Load C _{dyn} [N]	Stat. Load C ₀ [N]	Mass [kg/pc.]
R16-05T3-ZD	16	5	28	72	14	16	4	2,4	4	13,5	9600	12700	0,20
R20-05T4-ZD	20	5	36	86	15	20	4	2,4	4	17,5	13900	21800	0,39
R25-05T4-ZD	25	5	40	100	20	20	5	2,4	4	22,5	15600	27900	0,48
R25-10T3-ZD	25	10	48	115	20	20	5	2,4	4	21,0	24100	36200	0,80
R32-05T5-ZD	32	5	48	100	20	20	5	2,4	4	29,5	20700	43900	0,63
R32-10T3-ZD	32	10	56	136	25	25	6	2,4	4	27,8	32000	47500	1,30
R32-20T2-ZD	32	20	56	142	28	25	6	2,4	4	27,8	20300	26800	1,30
R40-05T5-ZD	40	5	56	108	20	20	6	2,4	4	37,5	22500	54600	0,78
R40-10T4-ZD	40	10	62	142	28	25	6	2,4	4	35,8	46500	82600	1,34
R40-20T2-ZD	40	20	62	146	30	25	6	2,4	4	35,8	23800	36400	1,51
R50-05T5-ZD	50	5	68	108	20	20	6	2,4	4	47,5	24900	69800	1,40
R50-10T4-ZD	50	10	72	168	35	25	8	2,4	4	45,8	52800	106800	1,72
R50-20T3-ZD	50	20	72	190	47	25	6	2,4	4	45,8	40000	76200	1,95
R63-10T6-ZD	63	10	85	208	44	32	6	3,5	6	58,8	84700	210800	2,81
R63-20T4-ZD	63	20	95	260	65	32	6	3,5	6	55,4	105000	250000	7,30
R80-10T6-ZD	80	10	105	208	44	32	6	3,5	6	75,8	93400	269200	5,50
R80-20T4-ZD	80	20	125	285	55	32	8	4,1	8	72,4	135000	322000	14,90

- Nuts with dirt wipers
- Precision ground ball tracks
- Left-handed nuts on request

Order example: **R** 16 **05** T3 **ZD** 420 **495** 0,052

2.3.8 Cylindrical single nut with screw-in thread SE

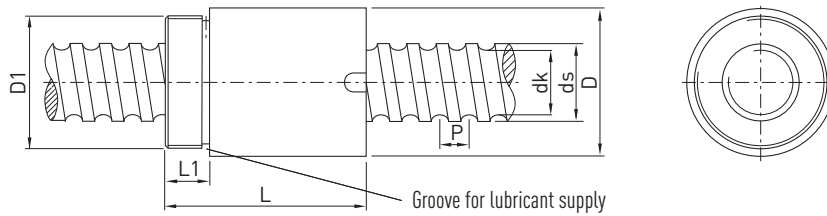

Table 2.13 Nut dimensions

Article number	ds h6	P	D -0,2	D1	L -0,5	L1	dk	Dyn. Load C _{dyn} [N]	Stat. Load C ₀ [N]	Axial play max. [mm]	Mass [kg/pc.]
R16-05T3-SE	16	5	36	M30 × 1,5	42	12	13,5	9600	12700	0,02	0,45
R20-05T4-SE	20	5	40	M35 × 1,5	52	12	17,5	13900	21800	0,02	0,53
R25-05T4-SE	25	5	45	M40 × 1,5	60	15	22,5	15600	27900	0,02	0,82
R25-10T3-SE	25	10	48	M45 × 1,5	70	15	21,0	24100	36200	0,02	1,00
R32-05T5-SE	32	5	52	M48 × 1,5	60	15	29,5	20700	43900	0,02	1,13
R32-10T3-SE	32	10	56	M52 × 1,5	80	15	27,8	34100	56100	0,02	1,13
R32-20T2-SE	32	20	56	M52 × 1,5	80	15	27,8	20300	26800	0,02	1,44
R40-05T5-SE	40	5	65	M60 × 1,5	68	18	37,5	22500	54600	0,02	1,63
R40-10T4-SE	40	10	65	M60 × 1,5	88	18	35,8	46800	82600	0,02	1,75
R40-20T2-SE	40	20	65	M60 × 1,5	88	18	35,8	23800	36400	0,03	1,75
R50-10T4-SE	50	10	80	M75 × 1,5	100	20	45,8	52800	106800	0,02	2,96
R50-20T3-SE	50	20	80	M75 × 1,5	114	20	45,8	40000	76200	0,03	3,15
R63-10T6-SE	63	10	95	M85 × 2	120	20	58,8	84700	210800	0,04	4,37
R63-20T3-SE	63	20	95	M85 × 2	138	20	55,4	96000	189000	0,04	4,40

- Reduced axial play on request
- Nuts with dirt wipers
- Precision ground ball tracks
- Left-handed nuts on request

Order example: **R** **20** **05** **T4** **SE** **600** **680** **0,052**

Ballscrews

Peeled Ballscrews

2.3.9 Safety nut SEM

The safety nut comprises a ball thread unit and safety unit. The safety nut basically works like a normal ballscrew nut. If the axial backlash is increased due to wear, ball failure or ball loss, the thread of the safety unit comes into contact with the ball thread. The nut cannot therefore break out. The normal function of the unit is guaranteed up to an axial backlash of 0.4 mm.

Areas of application:

- Lifting equipment
- Clamping fixtures
- Lifting platforms
- Elevators

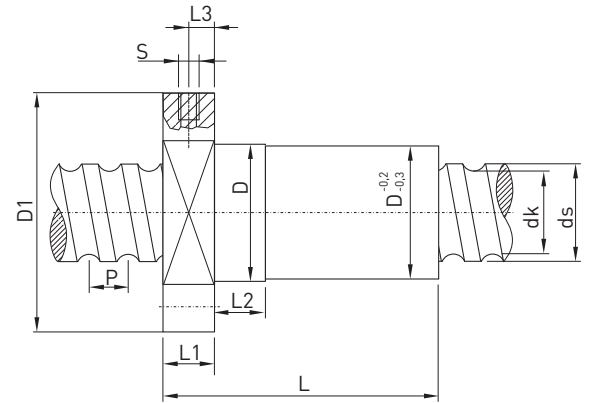
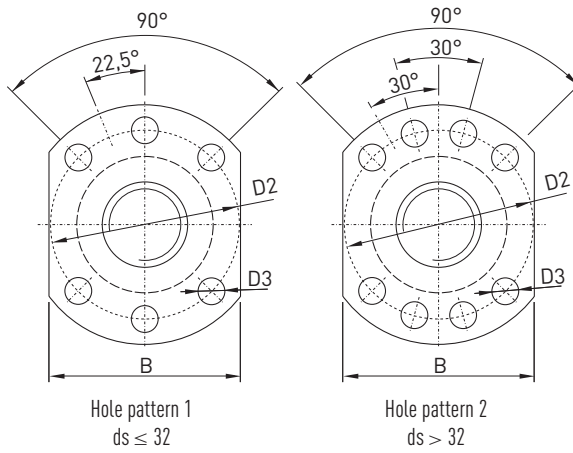
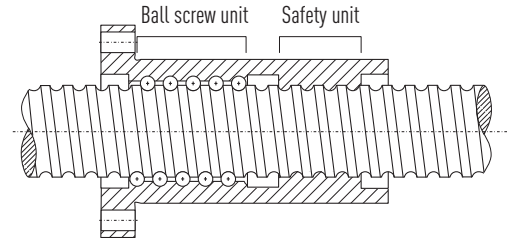

Table 2.14 Safety nut dimensions

Article number	ds h6	P	D g7	D1	D2	D3	Hole pattern	L	L1	L2	L3	S	B	dk	Dyn. Load C _{dyn} [N]	Stat. Load C ₀ [N]
R32-10T4-SEM	32	10	56	86	70	9	1	130	15	16	7,5	M6 × 1	66	27,8	40900	63200
R40-10T4-SEM	40	10	63	93	78	9	2	130	15	16	7,5	M8 × 1	70	35,8	46800	82500
R40-20T2-SEM	40	20	63	93	78	9	2	140	15	16	7,5	M8 × 1	70	35,8	23800	36400
R50-10T5-SEM	50	10	75	110	93	11	2	145	16	16	8,0	M8 × 1	85	45,8	63900	133300
R63-20T4-SEM	63	20	95	135	115	13,5	2	205	20	25	10,0	M8 × 1	100	55,4	105000	250000
R80-20T5-SEM	80	20	125	165	145	13,5	2	230	25	25	12,5	M8 × 1	130	72,4	161500	398000

Simply using a safety nut does not provide sufficient protection against a load being lowered unintentionally. The safety guidelines valid for the application must be observed. Other measures, such as monitoring the motor current and the driveline, should be in place.

- Reduced axial play on request
- Nuts with dirt wipers
- Precision ground ball tracks
- Left-handed nuts on request

Order example:

R	32	10	T4	SEM	1200	1350	0,052
---	----	----	----	-----	------	------	-------

2.3.10 Driven nut unit AME

The threaded nut is mounted in an axial angular ball bearing ZKLF...2Z. The less stringent PE version is preferred. The bearing has defined preload using a precision groove nut from the HIR series. The bearing achieves a good resistance to tilting thanks to the O arrangement of the two rows of balls. Any axial and radial forces which arise are absorbed with ease. The thick-walled, dimensionally-stable outer bearing race is screwed directly onto the bearing block.

There is no need for an extra bearing bush or bearing cover. Circulating oil lubrication supplies the bearing with lubricant. The ballscrew nut is lubricated via a radial bore in the shaft. The less stringent axial angular ball bearing can only be lubricated axially. We are happy to develop the right unit for any application, taking due account of different installation circumstances. A wide range of realised applications provides the ideal basis for finding a solution to your problem.

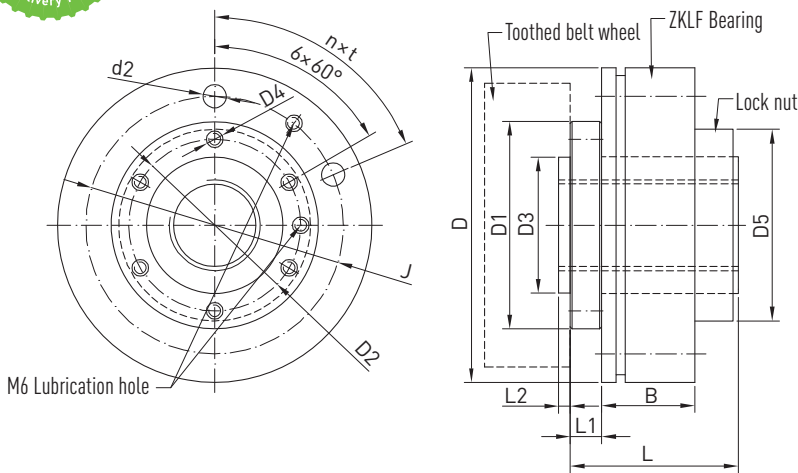

Table 2.15 Nut dimensions

Article number	Shaft dimensions			Nut dimensions								Bearing dimensions					Dyn. Load C_{dyn} [N]	Stat. Load C_0 [N]	n max. [rpm]
	ds h6	P	dk	D1	D2	D3 h8	D4	D5	L	L1	L2	D -0,01	J	n x t	d2	B			
R16-05T3-AME	16	5	13,5	50	40	30	M6	47	50	10	3	80	63	6 x (60°)	6,5	28	9600	12700	4000
R20-05T4-AME	20	5	17,5	63	52	40	M6	60	60	12	5	100	80	4 x (90°)	8,5	34	13900	21800	3300
R25-05T4-AME	25	5	22,5	76	60	50	M6	72	63	15	5	115	94	6 x (60°)	8,5	34	15600	27900	3000
R25-10T3-AME	25	10	21,0	76	60	50	M6	72	74	15	5	115	94	6 x (60°)	8,5	34	24100	36200	3000
R32-05T5-AME	32	5	29,5	76	62	50	M8	72	70	15	5	115	94	6 x (60°)	8,5	34	20700	43900	3000
R32-10T4-AME	32	10	27,8	76	62	50	M8	72	105	15	5	115	94	6 x (60°)	8,5	34	40900	63200	3000
R32-20T2-AME	32	20	27,8	76	62	50	M8	72	100	15	5	115	94	6 x (60°)	8,5	34	20300	26800	3000
R40-05T5-AME	40	5	37,5	90	70	60	M8	82	76	15	5	145	120	8 x (45°)	8,5	45	22500	54600	2400
R40-10T3-AME	40	10	35,8	90	70	60	M8	82	85	15	5	145	120	8 x (45°)	8,5	45	37100	61900	2400
R40-20T2-AME	40	20	35,8	90	70	60	M8	82	105	15	5	145	120	8 x (45°)	8,5	45	23800	36400	2400
R50-05T5-AME	50	5	47,5	100	84	70	M10	94	78	15	5	155	130	8 x (45°)	8,5	45	24900	69800	2200
R50-10T4-AME	50	10	45,8	100	84	70	M10	94	95	15	5	155	130	8 x (45°)	8,5	45	52800	106800	2200
R50-20T3-AME	50	20	45,8	100	84	70	M10	94	120	15	5	155	130	8 x (45°)	8,5	45	40000	76200	2200
R63-10T6-AME	63	10	58,8	130	110	90	M10	122	120	20	7	190	165	8 x (45°)	10,5	55	84700	210800	1800

- Reduced axial play on request
- Nuts with dirt wipers
- Precision ground ball tracks
- Left-handed nuts on request

Order example: **R** 40 **20** T2 **AME** 3800 **3900** 0,052

Ballscrews

Accessories

2.4 Accessories

2.4.1 Shaft ends and bearing configuration

To reduce the amount of design work required, we provide standardised end machining processes and bearing units. We recommend the "B", "E" and "F" bearing series for simple applications and low axial forces. They are suited to all tasks in applications where the ballscrew is not subject to stringent requirements. The SFA and SLA bearing units are suited to more challenging applications. The WBK series is available for heavy-duty applications.

When selecting the suitable bearing type, the permissible axial force of the fixed bearing must also be taken into account.

Types of assembly

The type of installation and mounting of the ballscrew shafts are decisive for rigidity, critical speed and buckling load. This must be given careful consideration when selecting the type of assembly.

Table 2.16 Overview of standard shaft ends for SFA, SLA bearing series

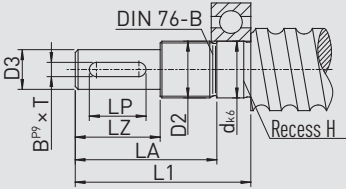
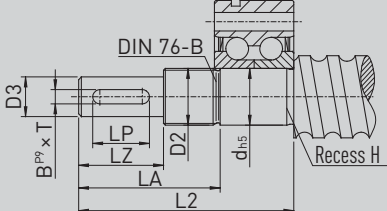
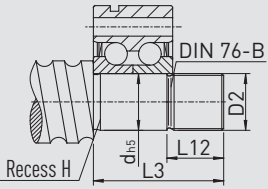
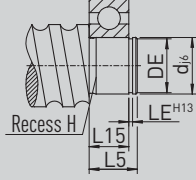
	
<p>Type S1 Bearing: Deep groove ball bearing 60.. or 62.. For SLA bearing unit</p>	<p>Type S2 Bearing: ZKLF.. or ZKLN.. For SFA bearing unit</p>
	
<p>Type S3 Bearing: ZKLF.. or ZKLN.. For SFA bearing unit</p>	<p>Type S5 Bearing: Deep groove ball bearing 62.. For SLA bearing unit</p>

Example:

Designation of shaft end, type S2, with the fit diameter $d = 20$: S2-20.

Table 2.17 Dimensions of standard shaft ends for SFA, SLA bearing series

Shaft end type	BS nominal \emptyset	d	D2	D3	L1	L2	L3	L5	L12	L15	DE	LE	LA	LP	LZ	$B^{P9} \times T$	Recess H
S_-06	12	6	M6 \times 0,5	5 j6	31	37	—	8	—	6	5,7 h10	0,8	26	—	16	—	10002475
S_-10	15, 16	10	M10 \times 0,75	8 j6	39	50	30	12	12	9	9,6 h10	1,1	32	14	20	2 \times 1,2	10002475
S_-12	20	12	M12 \times 1	10 j6	43	58	35	13	12	10	11,5 h11	1,1	35	16	23	3 \times 1,8	10002475
S_-17	25	17	M17 \times 1	14 j6	60	73	43	15	20	12	16,2 h11	1,1	50	20	30	5 \times 3	10002475
S_-20	25*, 32	20	M20 \times 1	14 j6	62	76	46	17	20	14	19 h12	1,3	50	20	30	5 \times 3	DIN509-E0,6 \times 0,3
S_-25	32**, 40	25	M25 \times 1,5	20 j6	83	96	46	19	20	15	23,9 h12	1,3	71	36	50	6 \times 3,5	DIN509-E0,6 \times 0,3
S_-30	40	30	M30 \times 1,5	25 j6	95	108	48	20	22	16	28,6 h12	1,6	82	45	60	8 \times 4	10002476
S_-40	50	40	M40 \times 1,5	32 k6	119	135	55	22	24	18	37,5 h12	1,85	104	56	80	10 \times 5	DIN509-E0,6 \times 0,3
S_-50	63	50	M50 \times 1,5	40 k6	142	155	55	25	24	20	47 h12	2,15	124	70	100	12 \times 5	10002476
S_-60	80	60	M60 \times 2	50 k6	155	177	67	28	25	22	57 h12	2,15	135	70	110	14 \times 5,5	10002476

Unit: mm

* depending on actual shaft outer diameter $d_{s \min} = 24.5$; ** depending on actual shaft outer diameter $d_{s \min} = 31.5$

It goes without saying that we also machine the shaft ends to your drawings and individual requirements.

Table 2.18 Overview of standard shaft ends for EK, BK, FK, EF, BF, FF bearing series

<p>Type E8 Bearing: 70.. For EK, FK bearing units</p>	<p>Type E9 Bearing: 72.. For BK bearing unit</p>
<p>Type E10 Bearing: Deep groove ball bearing 60.. or 62.. For EF, BF, FF bearing unit</p>	

Example:

Designation of shaft end, type S3, with the fit diameter $d = 10$: S3-10.

Table 2.19 Dimensions of standard shaft ends for EK, BK, FK, EF, BF, FF bearing series

Shaft end type	BS nominal \varnothing	d h6	D4 j6	D5	D10 j6	L8	L9	L10	L16	L17	DE -0,2	LB	LC	LP	B ^{p9} × T	C	Recess H
E_-08	12	8	6	M8 × 1	6	41	—	9	6	0,8	5,8	9	19	—	—	5,5	DIN509-E0,6 × 0,2
E_-10	15, 16	10	8	M10 × 1	8	56	—	10	7	0,9	7,7	20	31	14	2 × 1,2	5,5	DIN509-E0,6 × 0,2
E_10-12 E_08-12	16*	12	10	M12 × 1	10	59	—	11	8	1,15	9,6	23	34	16	3 × 1,8	5,5	10002475 DIN509-E0,6 × 0,2
E_-15	20	15	12	M15 × 1	15	70	—	13	9	1,15	14,3	23	36	16	4 × 2,5	10	DIN509-E0,6 × 0,2
E_-20	25	20	17	M20 × 1	20	92	—	19	14	1,35	19,0	30	47	20	5 × 3,0	11	DIN509-E0,6 × 0,3
E_-25	32	25	20	M25 × 1,5	25	126	115	20	15	1,35	23,9	50	70 (68) ²⁾	36	6 × 3,5	15 (9) ²⁾	DIN509-E0,8 × 0,3
E_-30	40	30	25	M30 × 1,5	30	132	132	21	16	1,75	28,6	60	85	45	8 × 4,0	9	10002476
E_-40	50	40	35 ¹⁾	M40 × 1,5	40	—	173	23	18	1,95	38,0	80	115	56	10 × 5	15	DIN509-E0,8 × 0,3

Unit: mm

* depending on actual shaft outer diameter $d_{s\min} = 15.5$

¹⁾ tolerance k6

²⁾ for BK 25

It goes without saying that we also machine the shaft ends to your drawings and individual requirements.

Ballscrews

Accessories

Table 2.20 Overview of standard shaft ends for WBK bearing series

<p>Type W1 Bearing: BSB.. For WBK_DF bearing units</p>	<p>Type W2 Bearing: BSB.. For WBK_DFD bearing units</p>
<p>Type W3 Bearing: BSB.. For WBK_DFF bearing units</p>	

Example:

Designation of shaft end, type W2, with the fit diameter $d = 20$: W2-20.

Table 2.21 Dimensions of standard shaft ends for WBK bearing series

Shaft end type	BS nominal \emptyset	d h6	D4 j6	D5	L11	L12	L13	LB	LC	LP	B ^{p9} × T	Recess H
W_-15	20	15	12	M15 × 1	104	—	—	23	46	16	4 × 2,5	DIN509-E0,6 × 0,2
W_-17	25	17	14	M17 × 1	111	—	—	30	53	20	5 × 3,0	10002475
W_-20*	25	20	17	M20 × 1	111	—	—	30	53	20	5 × 3,0	DIN509-E0,6 × 0,3
W_-25**	32	25	20	M25 × 1,5	139	154	—	50	76	36	6 × 3,5	DIN509-E0,8 × 0,3
W_-30	40	30	25	M30 × 1,5	149	164	—	60	86	45	8 × 4,0	10002476
W_-35	45	35	30	M35 × 1,5	152	167	182	60	90	45	8 × 4,0	DIN509-E0,8 × 0,3
W_-40	50	40	35 ¹⁾	M40 × 1,5	172	187	202	80	110	56	10 × 5,0	DIN509-E0,8 × 0,3

Unit: mm

* Depending on actual shaft outer diameter $d_{s\min} = 24.5$; ** depending on actual shaft outer diameter $d_{s\min} = 31.5$

¹⁾ tolerance k6

It goes without saying that we also machine the shaft ends to your drawings and individual requirements.

Table 2.22 HIWIN recesses

<p>HIWIN recess 10002475</p>	<p>HIWIN recess 10002476</p>

Table 2.23 Overview of bearing type and associated end machining for SLA, SFA bearing units

BS nominal Ø	Fixed bearing		Supported bearing	
	Pillow block	End machining	Pillow block	End machining
12	SFA-06	S2-06 / S3-06	SLA-06	S1-06 / S5-06
15, 16	SFA-10	S2-10 / S3-10	SLA-10	S1-10 / S5-10
20	SFA-12	S2-12 / S3-12	SLA-12	S1-12 / S5-12
25	SFA-17	S2-17 / S3-17	SLA-17	S1-17 / S5-17
32	SFA-20	S2-20 / S3-20	SLA-20	S1-20 / S5-20
40	SFA-30	S2-30 / S3-30	SLA-30	S1-30 / S5-30
50	SFA-40	S2-40 / S3-40	SLA-40	S1-40 / S5-40

Table 2.24 Overview of bearing type and associated end machining for EK, BK, FK, EF, BF, FF bearing series

BS nominal Ø	Fixed bearing				Supported bearing			
	Pillow block	End machining	Flange bearing	End machining	Pillow block	End machining	Flange bearing	End machining
12	EK08	E8-08	FK08	E8-08	EF08	E10-08	—	—
15, 16	EK10	E8-10	FK10	E8-10	EF10	E10-10	FF10	E10-10
16*	EK12	E8-12	FK12	E8-12	EF12	E10-12	FF12	E10-12
20	EK15	E8-15	FK15	E8-15	EF15	E10-15	FF15	E10-15
25	EK20	E8-20	FK20	E8-20	EF20	E10-20	FF20	E10-20
32	BK25	E9-25	FK25	E8-25	BF25	E10-25	FF25	E10-25
40	BK30	E9-30	FK30	E8-30	BF30	E10-30	FF30	E10-30
50	BK40	E9-40	—	—	BF40	E10-40	—	—

* depending on actual shaft outer diameter $d_{s \min} = 15.5$

Table 2.25 Overview of bearing type and associated end machining for WBK bearing unit

BS nominal Ø	Flange bearing	End machining
20	WBK 15 DF	W1-15
25	WBK 17 DF	W1-17
25	WBK 20 DF	W1-20
32	WBK 25 DF	W1-25
32	WBK 25 DFD	W2-25
40	WBK 30 DF	W1-30
40	WBK 30 DFD	W2-30
45	WBK 35 DF	W1-35
45	WBK 35 DFD	W2-35
45	WBK 35 DFF	W3-35
50	WBK 40 DF	W1-40
50	WBK 40 DFD	W2-40
50	WBK 40 DFF	W3-40

Ballscrews

Accessories

2.4.2 WBK bearing series

Thanks to their robust steel bearing housing, the flange bearing units of the WBK series are especially suited to use in heavy-duty ballscrews. Depending on the axial loads present, the WBK bearing units are available with the DF, DFD and DFF bearing arrangements. The end machining processes suited to the WBK fixed bearing are types W1, W2 and W3 (page 108).

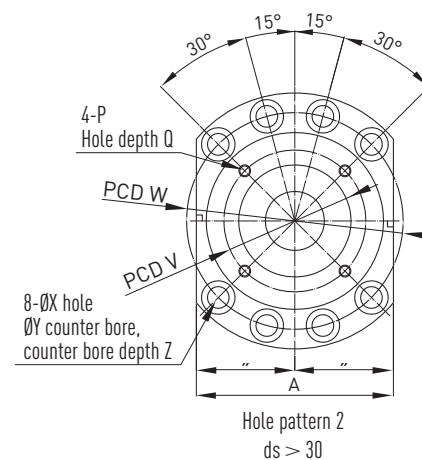
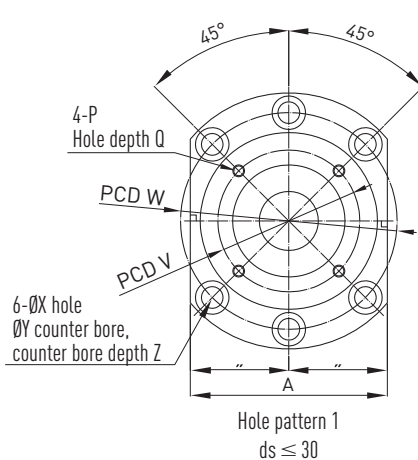
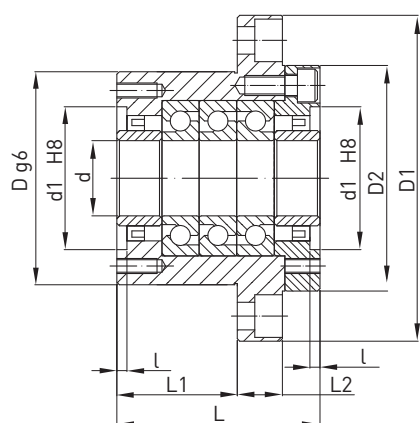
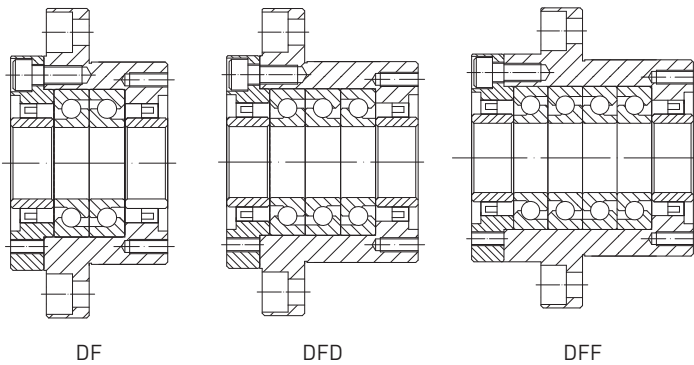

Table 2.26 Bearing unit dimensions

Article number	Shaft nominal \varnothing	d	D	D1	D2	L	L1	L2	A	W	X	Y	Z	d1	l	V	P	Q
WBK 15 DF	20	15	70	106	72	60	32	15	80	88	9	14,0	8,5	45	3	58	M5	10
WBK 17 DF	25	17	70	106	72	60	32	15	80	88	9	14,0	8,5	45	3	58	M5	10
WBK 20 DF	25	20	70	106	72	60	32	15	80	88	9	14,0	8,5	45	3	58	M5	10
WBK 25 DF	32	25	85	130	90	66	33	18	100	110	11	17,5	11,0	57	4	70	M6	12
WBK 25 DFD	32	25	85	130	90	81	48	18	100	110	11	17,5	11,0	57	4	70	M6	12
WBK 30 DF	40	30	85	130	90	66	33	18	100	110	11	17,5	11,0	57	4	70	M6	12
WBK 30 DFD	40	30	85	130	90	81	48	18	100	110	11	17,5	11,0	57	4	70	M6	12
WBK 35 DF	45	35	95	142	102	66	33	18	106	121	11	17,5	11,0	69	4	80	M6	12
WBK 35 DFD	45	35	95	142	102	81	48	18	106	121	11	17,5	11,0	69	4	80	M6	12
WBK 35 DFF	45	35	95	142	102	96	48	18	106	121	11	17,5	11,0	69	4	80	M6	12
WBK 40 DF	50	40	95	142	102	66	33	18	106	121	11	17,5	11,0	69	4	80	M6	12
WBK 40 DFD	50	40	95	142	102	81	48	18	106	121	11	17,5	11,0	69	4	80	M6	12
WBK 40 DFF	50	40	95	142	102	96	48	18	106	121	11	17,5	11,0	69	4	80	M6	12

Unit: mm

Bearing arrangements



Bearing setup

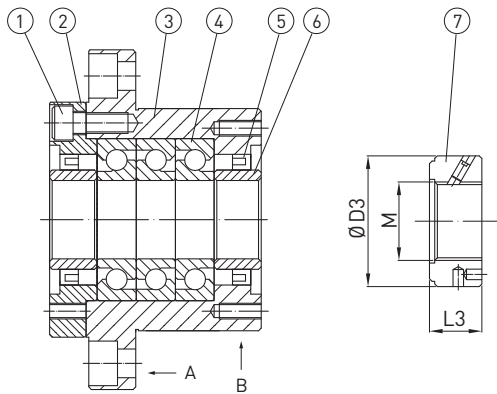

(1) Mounting bolt, (2) Bearing cover, (3) Bearing housing, (4) Bearing, (5) Seal, (6) Spacer, (7) Lock nut

Note:

1. Use reference planes A and B for alignment during assembly.
2. To ensure high accuracy, parts 1 – 6 must not be disassembled.

Table 2.27 **Technical data of bearing**

Article number	Dynamic load rating [kN]	Permissible axial load [kN]	Preload [kN]	Axial rigidity [N/μm]	Starting torque [Nm]	Lock nut [mm]			Weight [kg]
						M	D ₃	L ₃	
WBK 15 DF	21,9	26,6	2,15	750	0,19	M15 × 1	30	14	1,9
WBK 17 DF	21,9	26,6	2,15	750	0,19	M17 × 1	32	16	1,9
WBK 20 DF	21,9	26,6	2,15	750	0,19	M20 × 1	38	16	1,9
WBK 25 DF	28,5	40,5	3,15	1000	0,29	M25 × 1,5	38	18	3,1
WBK 25 DFD	46,5	81,5	4,30	1470	0,39	M25 × 1,5	38	18	3,4
WBK 30 DF	29,2	43,0	3,35	1030	0,30	M30 × 1,5	45	18	3,0
WBK 30 DFD	47,5	86,0	4,50	1520	0,40	M30 × 1,5	45	18	3,3
WBK 35 DF	31,0	50,0	3,80	1180	0,34	M35 × 1,5	52	18	3,4
WBK 35 DFD	50,5	100,0	5,20	1710	0,45	M35 × 1,5	52	18	4,3
WBK 35 DFF	50,5	100,0	7,65	2350	0,59	M35 × 1,5	52	18	5,0
WBK 40 DF	31,5	52,0	3,90	1230	0,36	M40 × 1,5	58	20	3,6
WBK 40 DFD	51,5	104,0	5,30	1810	0,47	M40 × 1,5	58	20	4,2
WBK 40 DFF	51,5	104,0	7,85	2400	0,61	M40 × 1,5	58	20	4,7

Ballscrews

Accessories

2.4.3 SFA/SLA bearing series

2.4.3.1 Fixed bearing SFA

The axis height of the fixed bearing is matched to supported bearing SLA (page 114) and nut housing GFD (page 115). The pillow block can be screwed on from above (S1) and below (S2).

The reference edge makes it easier to align the unit. The fixed bearing can be pinned with two tapered pins or cylindrical pins. The end machining suited to the fixed bearing is the S2-xx/S3-xx type (page 106).

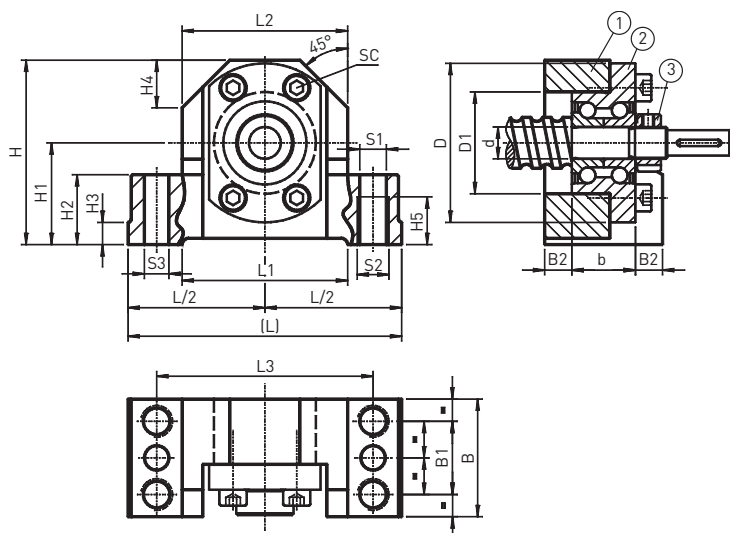

(1) Steel pillow block, (2) Bearing, (3) Lock nut

Table 2.28 Bearing unit dimensions

Article number	Shaft nominal \varnothing	L	L/2 js9	L1	L2	L3	H	H1 js9	H2	H3	H4	H5	d	D	D1	b
SFA06	12	62	31	34	38	50	41	22	13	5	11	9	6	30	19	12
SFA10	16	86	43	52	52	68	58	32	22	7	15	15	10	50	32	20

Unit: mm

Table 2.29 Bearing unit dimensions

Article number	Shaft nominal \varnothing	B	B1	B2	S1 H12	S2	S3	SC DIN 912 10.9
SFA06	12	32	16	10	5,3	M6	3,7	4 × M3 × 12
SFA10	16	37	23	8,5	8,4	M10	7,7	4 × M5 × 20

Unit: mm

Table 2.30 Technical data of bearing

Article number	Bearing type	C_0 axial [N]	C_{dyn} axial [N]	Max. speed [n/min]	Lock nut			
					Type	Nut tightening torque [Nm]	Screw size	Screw tightening torque [Nm]
SFA06	ZKLFA0630.2Z	6100	4900	14000	HIR 06	2	M4	1
SFA10	ZKLFA1050.2RS	8500	6900	6800	HIR 10	6	M4	1

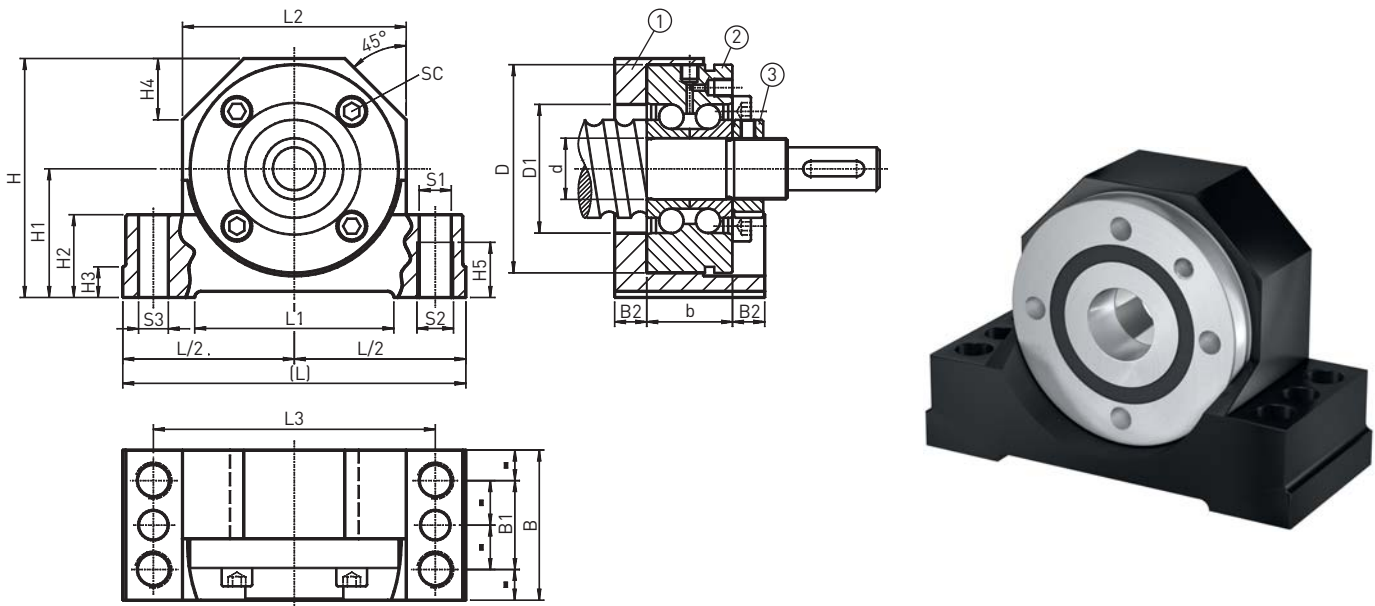

(1) Steel pillow block, (2) Bearing, (3) Lock nut

Table 2.31 Bearing unit dimensions

Article number	Shaft nominal \varnothing	L	L/2 js9	L1	L2	L3	H	H1 js9	H2	H3	H4	H5	d	D	D1	b
SFA12	20	94	47	52	60	77	64	34	22	7	17	15	12	55	32	25
SFA17	25	108	54	65	66	88	72	39	27	10	19	18	17	62	36	25
SFA20	32	112	56	65	73	92	78	42	27	10	20	18	20	68	42	28
SFA30	40	126	63	82	84	105	92	50	32	13	23	21	30	80	52	28
SFA40	50	146	73	82	104	125	112	60	32	13	30	21	40	100	66	34

Unit: mm

Table 2.32 Bearing unit dimensions

Article number	Shaft nominal \varnothing	B	B1	B2	S1 H12	S2	S3	SC DIN 912 10.9
SFA12	20	42	25	8,5	8,4	M10	7,7	3 × M6 × 35
SFA17	25	46	29	10,5	10,5	M12	9,7	3 × M6 × 35
SFA20	32	49	29	10,5	10,5	M12	9,7	4 × M6 × 40
SFA30	40	53	32	12,5	12,6	M14	9,7	6 × M6 × 40
SFA40	50	59	34	12,5	12,6	M14	9,7	4 × M8 × 50

Unit: mm

Table 2.33 Technical data of the bearing

Article number	Bearing type	C_0 axial [N]	C_{dyn} axial [N]	Max. speed [n/min]	Lock nut			
					Type	Nut tightening torque [Nm]	Screw size	Screw tightening torque [Nm]
SFA-12	ZKLF1255.2RS	24700	17000	3800	HIR 12	8	M4	1
SFA-17	ZKLF1762.2RS	31000	18800	3300	HIR 17	15	M5	3
SFA-20	ZKLF2068.2RS	47000	26000	3000	HIR 20 × 1	18	M5	3
SFA-30	ZKLF3080.2RS	64000	29000	2200	HIR 30	32	M6	5
SFA-40	ZKLF40100.2RS	101000	43000	1800	HIR 40	55	M6	5

Ballscrews

Accessories

2.4.3.2 Supported bearing SLA

The axis height of the supported bearing is matched to fixed bearing SFA (page 112) and nut housing GFD (page 115). The pillow block can be screwed on from above (S1) and below (S2).

The reference edge makes it easier to align the unit. The end machining suited to the supported bearing is the S1-xx/S5-xx type (page 106).

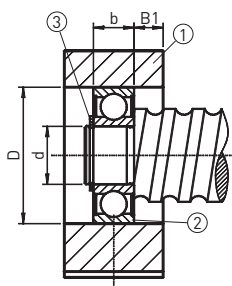
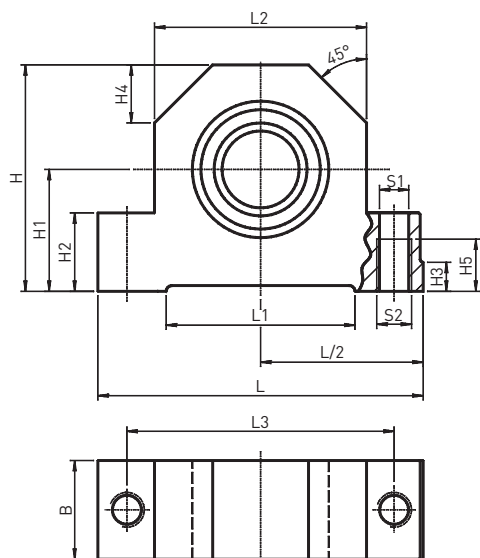

(1) Steel pillow block, (2) Bearing, (3) Lock nut

Table 2.34 Bearing unit dimensions

Article number	Shaft nominal \varnothing	L	L/2 js9	L1	L2	L3	H	H1 js9	H2	H3	H4	H5	b
SLA06	12	62	31	34	38	50	41	22	13	5	11	9	6
SLA10	16	86	86	52	52	68	58	32	22	7	15	15	9
SLA12	20	94	47	52	60	77	64	34	22	7	17	15	10
SLA17	25	108	54	65	66	88	72	39	27	10	19	18	12
SLA20	32	112	56	65	73	92	78	42	27	10	20	18	14
SLA30	40	126	63	82	84	105	92	50	32	13	23	21	16
SLA40	50	146	73	82	104	125	112	60	32	13	30	21	18

Unit: mm

Table 2.35 Bearing unit dimensions

Article number	Shaft nominal \varnothing	B	B1	S1 H12	S2	d	D H6	Circlip DIN 471	Deep-groove ball bearing DIN 625
SLA06	12	15	4,5	5,3	M6	6	19	6 × 0,7	626.2RS
SLA10	16	24	7,5	8,4	M10	10	30	10 × 1	6200.2RS
SLA12	20	26	8	8,4	M10	12	32	12 × 1	6201.2RS
SLA17	25	28	8	10,5	M12	17	40	17 × 1	6203.2RS
SLA20	32	34	10	10,5	M12	20	47	20 × 1,2	6204.2RS
SLA30	40	38	11	12,6	M14	30	62	30 × 1,5	6206.2RS
SLA40	50	44	13	12,6	M14	40	80	40 × 1,75	6208.2RS

Unit: mm

2.4.4 Housing for flange nuts (DIN 69051 Part 5)

The nut housing is suitable for assembling flange nuts DEB (page 99), DDB (page 100) and FSCDIN (page 96). The axis height of the housing is matched to fixed bearing SFA (page 112) and the supported bearing SLA (page 114).

The housing can be screwed on from above (S1) and below (S2). The housing can be pinned with two tapered pins or cylindrical pins. Screws of strength class 8.8 should be used for the fastening.

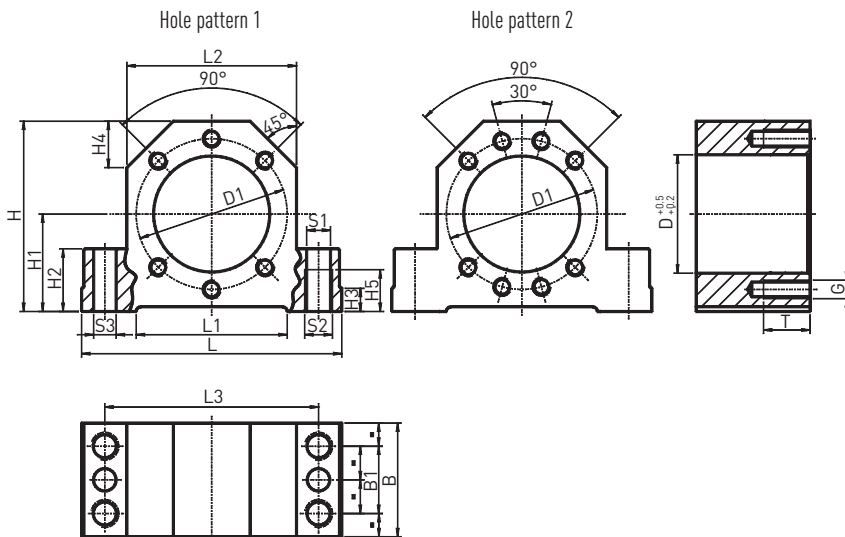

Table 2.36 Housing dimensions

Article number	Shaft nominal \varnothing	L	L1	L2	L3	H	H1 js9	H2	H3	H4	H5
GFD16	16	86	52	52	68	58	32	22	7	15	15
GFD20	20	94	52	60	77	64	34	22	7	17	15
GFD25	25	108	65	66	88	72	39	27	10	19	18
GFD32	32	112	65	72	92	82	42	27	10	19	18
GFD40	40	126	82	84	105	97	50	32	13	23	21
GFD50	50	146	82	104	125	115	60	32	13	30	21

Unit: mm

Table 2.37 Housing dimensions

Article number	Shaft nominal \varnothing	D	D1	B	B1	S1 H12	S2	S3	Hole pattern	G	T
GFD16	16	28	38	37	23	8,4	M10	7,7	1	M5	12
GFD20	20	36	47	42	25	8,4	M10	7,7	1	M6	15
GFD25	25	40	51	46	29	10,5	M12	9,7	1	M6	15
GFD32	32	50	65	49	29	10,5	M12	9,7	1	M8	20
GFD40	40	63	78	53	32	12,6	M14	9,7	2	M8	20
GFD50	50	75	93	59	34	12,6	M14	9,7	2	M10	25

Unit: mm

Ballscrews

Accessories

2.4.5 EK/EF bearing series

2.4.5.1 Fixed bearing EK

The axis height of the fixed bearing is matched to supported bearing EF (page 117). The end machining suited to fixed bearing EK is the E8-xx type (page 107).

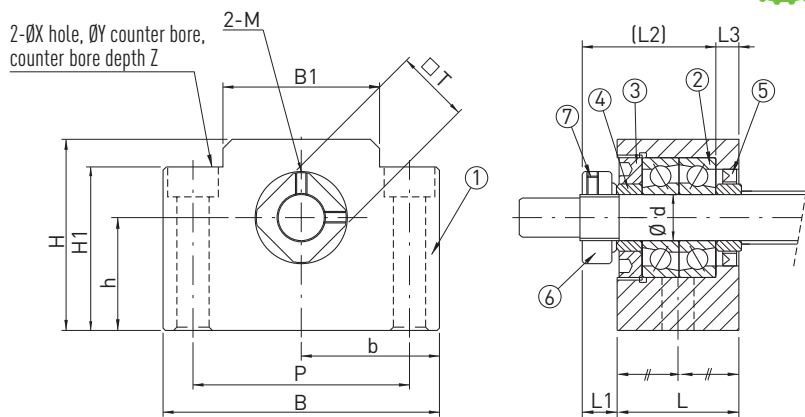

(1) Housing, (2) Bearing, (3) Retaining cover, (4) Support ring, (5) Seal, (6) Clamping nut, (7) Allen set screw

Table 2.38 Bearing unit dimensions

Article number	Shaft nominal \varnothing	d	L	L1	L2	L3	B	H	b $\pm 0,02$	h $\pm 0,02$	B1	H1	P	X	Y	Z	M	T
EK08	12	8	23	7	26	4	52	32	26	17	25	26	38	6,6	11	12	M3	14

Unit: mm

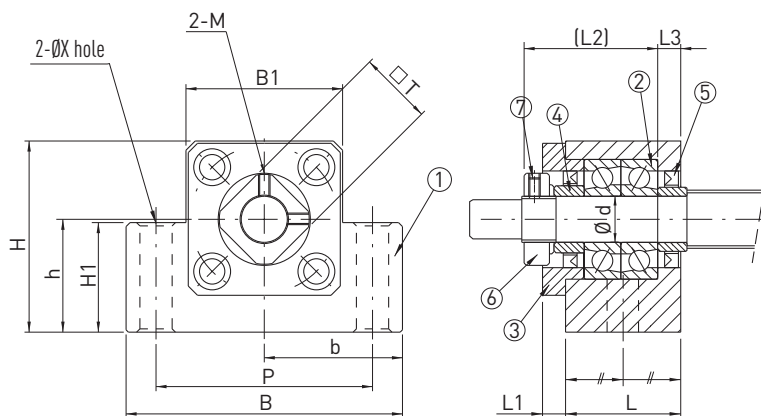

(1) Housing, (2) Bearing, (3) Retaining cover, (4) Support ring, (5) Seal, (6) Clamping nut, (7) Allen set screw

Table 2.39 Bearing unit dimensions

Article number	Shaft nominal \varnothing	d	L	L1	L2	L3	B	H	b $\pm 0,02$	h $\pm 0,02$	B1	H1	P	X	Y	Z	M	T
EK-10	16	10	24	6	29,5	6	70	43	35,0	25	36	24	52	9	—	—	M3	16
EK-12	16*	12	24	6	29,5	6	70	43	35,0	25	36	24	52	9	—	—	M4	19
EK-15	20	15	25	6	36,0	5	80	49	40,0	30	41	25	60	11	—	—	M4	22
EK-20	25	20	42	10	50,0	10	95	58	47,5	30	56	25	75	11	—	—	M4	30

Unit: mm

* depending on actual shaft outer diameter $d_{s\min} = 15,5$

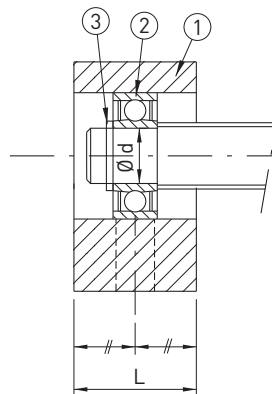
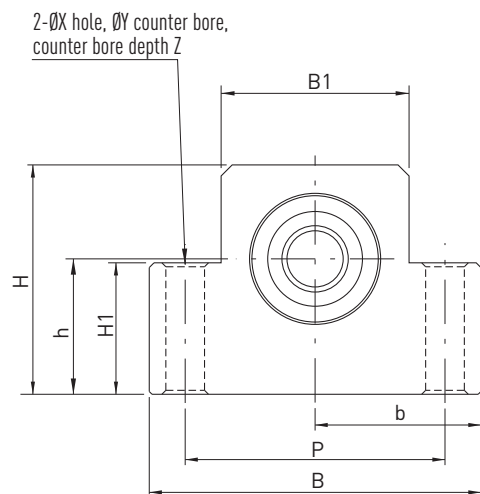

Table 2.40 **Technical data of bearing**

Article number	Bearing type	C ₀ axial [N]	C _{dyn} axial [N]	Max. permissible axial load [N]	Max. speed [n/min]	Lock nut			
						Type	Nut tightening torque [Nm]	Screw size	Screw tightening torque [Nm]
EK08	708	4800	2800	1100	40000	RN8	2,5	M3	0,6
EK10	7000A P0	8800	5200	2000	24000	RN10	2,9	M3	0,6
EK12	7001A P0	9400	6000	2200	22000	RN12	6,4	M4	1,5
EK15	7002A P0	10000	6900	2400	19000	RN15	7,9	M4	1,5
EK20	7204B P0	21600	15200	6800	9500	RN20	16,7	M4	1,5

2.4.5.2 Supported bearing EF

The axis height of the supported bearing is matched to fixed bearing EK (page 116). The end machining suited to supported bearing EF is the E10-xx type (page 107).



(1) Housing, (2) Bearing, (3) Circlip

Table 2.41 **Bearing unit dimensions**

Article number	Shaft nominal Ø	d	L	B	H	b ±0,02	h ±0,02	B1	H1	P	X	Y	Z	Bearing	Circlip
EF-08	12	6	14	52	32	26,0	17	25	26	38	6,6	11	12	606ZZ	S 06
EF-10	16	8	20	70	43	35,0	25	36	24	52	9,0	—	—	608ZZ	S 08
EF-12	16*	10	20	70	43	35,0	25	36	24	52	9,0	—	—	6000ZZ	S 10
EF-15	20	15	20	80	49	40,0	30	41	25	60	9,0	—	—	6002ZZ	S 15
EF-20	25	20	26	95	58	47,5	30	56	25	75	11,0	—	—	6204ZZ	S 20

Unit: mm

* depending on actual shaft outer diameter $d_{s\min} = 15,5$

Ballscrews

Accessories

2.4.6 BK/BF bearing series

2.4.6.1 Fixed bearing BK

The axis height of the fixed bearing is matched to supported bearing BF (page 119). The end machining suited to fixed bearing BK is the E9-xx type (page 107).

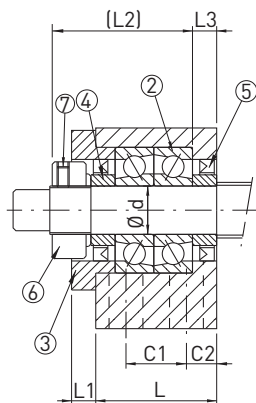
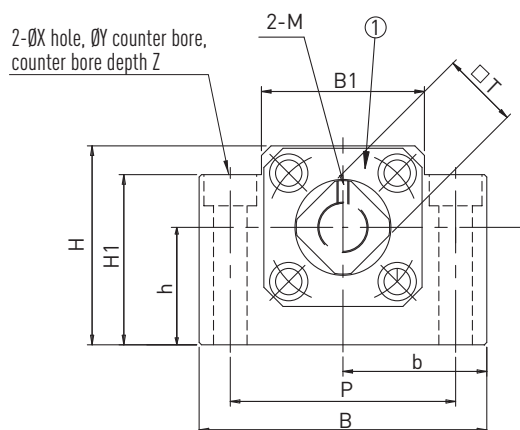

(1) Housing, (2) Bearing, (3) Retaining cover, (4) Support ring, (5) Seal, (6) Clamping nut, (7) Allen set screw

Table 2.42 Bearing unit dimensions

Article number	Shaft nominal \varnothing	d	L	L1	L2	L3	B	H	b $\pm 0,02$	h $\pm 0,02$
BK25	32	25	42	12	54	9	106	80	53	48
BK30	40	30	45	14	61	9	128	89	64	51
BK40	50	40	61	18	76	15	160	110	80	60

Unit: mm

Table 2.43 Bearing unit dimensions

Article number	Shaft nominal \varnothing	B1	H1	P	C1	C2	X	Y	Z	M	T
BK25	32	64	70	85	22	10	11	17	11,0	M5	35
BK30	40	76	78	102	23	11	14	20	13,0	M6	40
BK40	50	100	90	130	33	14	18	26	17,5	M8	50

Unit: mm

Table 2.44 Technical data of bearing

Article number	Bearing type	C_0 axial [N]	C_{dyn} axial [N]	Max. permissible axial load [N]	Max. speed [n/min]	Lock nut			
						Type	Nut tightening torque [Nm]	Screw size	Screw tightening torque [Nm]
BK25	7205A P0	26300	20500	7000	12000	RN25	21	M6	5
BK30	7206B P0	33500	27000	10600	7100	RN30	31	M6	5
BK40	7208B P0	52000	46100	18000	5300	RN40	71	M6	5

Note: BK25, BK30, BK40 with optional lubrication connection

2.4.6.2 Supported bearing BF

The axis height of the supported bearing is matched to fixed bearing BK (page 118).
The end machining suited to supported bearing BF is the E10-xx type (page 107).

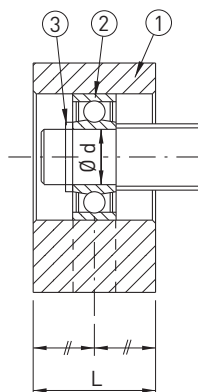
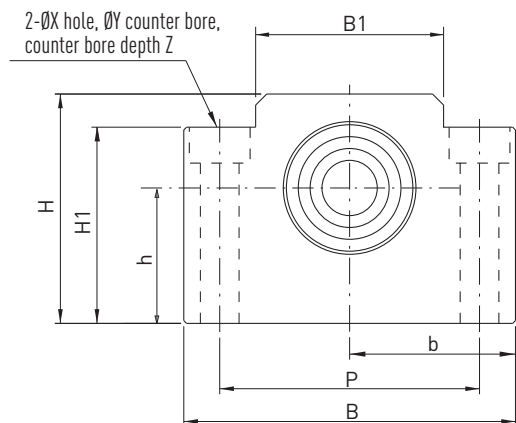

(1) Housing, (2) Bearing, (3) Circlip

Table 2.45 Bearing unit dimensions

Article number	Shaft nominal \varnothing	d	L	B	H	b $\pm 0,02$	h $\pm 0,02$	B1	H1	P	X	Y	Z	Bearing	Circlip
BF25	32	25	30	106	80	53	48	64	70	85	11	17	11,0	6205ZZ	S 25
BF30	40	30	32	128	89	64	51	76	78	102	14	20	12,0	6206ZZ	S 30
BF40	50	40	37	160	110	80	60	100	90	130	18	26	17,5	6208ZZ	S 40

Unit: mm

Ballscrews

Accessories

2.4.7 FK/FF bearing series

2.4.7.1 Fixed bearing FK

The associated supporting bearing unit is the FF bearing series (page 121). The end machining suited to fixed bearing FK is the E8-xx type (page 107).

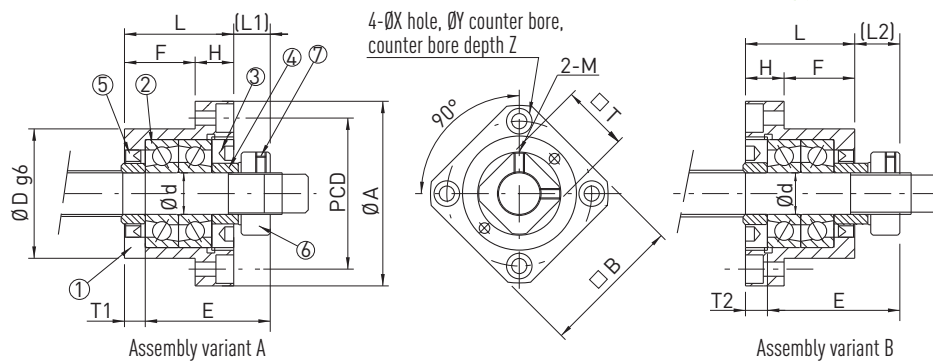

(1) Housing, (2) Bearing, (3) Retaining cover, (4) Support ring, (5) Seal, (6) Clamping nut, (7) Allen set screw

Table 2.46 Bearing unit dimensions

Article number	Shaft nominal \varnothing	d	L	H	F	E	D g6	A	PCD	B	Assembly variant A		Assembly variant B		X	Y	Z	M	T
											L1	T1	L2	T2					
FK08	12	8	23	9	14	26	28	43	35	35	7	4	8	5	3,4	6,5	4	M3	14

Unit: mm

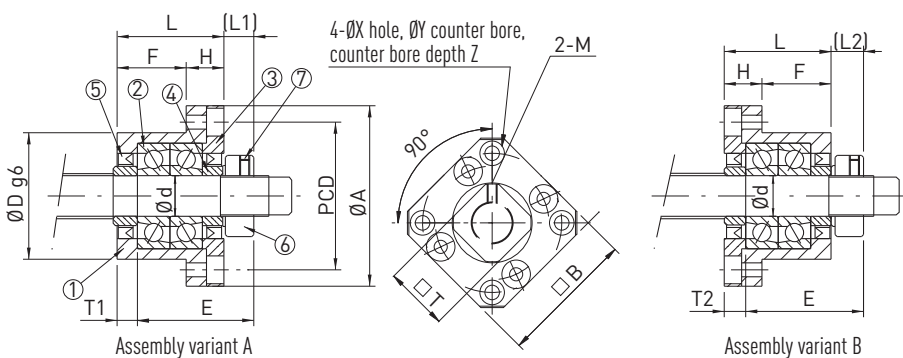

(1) Housing, (2) Bearing, (3) Retaining cover, (4) Support ring, (5) Seal, (6) Clamping nut, (7) Allen set screw



Table 2.47 Bearing unit dimensions

Article number	Shaft nominal \varnothing	d	L	H	F	E	D g6	A	PCD	B	Assembly variant A		Assembly variant B		X	Y	Z	M	T
											L1	T1	L2	T2					
FK10	16	10	27	10	17	29,5	34	52	42	42	7,5	5	8,5	6	4,5	8,0	4	M3	16
FK12	16*	12	27	10	17	29,5	36	54	44	44	7,5	5	8,5	6	4,5	8,0	4	M4	19
FK15	20	15	32	15	17	36,0	40	63	50	52	10,0	6	12,0	8	5,5	9,5	6	M4	22
FK20	25	20	52	22	30	50,0	57	85	70	68	8,0	10	12,0	14	6,6	11,0	10	M4	30
FK25	32	25	57	27	30	59,0	63	98	80	79	13,0	10	20,0	17	9,0	15,0	13	M5	35
FK30	40	30	62	30	32	61,0	75	117	95	93	11,0	12	17,0	18	11,0	17,5	15	M6	40

Unit: mm

* depending on actual shaft outer diameter $d_{s \min} = 15,5$

Note: FK10, FK12, FK15, FK20, FK25, FK30 optional with lubrication connection

Table 2.48 **Technical data of bearing**

Article number	Bearing type	C ₀ axial [N]	C _{dyn} axial [N]	Max. permissible axial load [N]	Max. speed [n/min]	Lock nut			
						Type	Nut tightening torque [Nm]	Screw size	Screw tightening torque [Nm]
FK08	708	4800	2800	1000	40000	RN8	2,5	M3	0,6
FK10	7000A P0	8800	5200	1900	24000	RN10	2,9	M3	0,6
FK12	7001A P0	9400	6000	2200	22000	RN12	6,4	M4	1,5
FK15	7002A P0	10000	6900	2400	19000	RN15	7,9	M4	1,5
FK20	7204B P0	21600	15300	6800	9500	RN20	16,7	M4	1,5
FK25	7205B P0	24000	19000	8100	8500	RN25	20,6	M6	4,9
FK30	7206B P0	33500	27000	10600	7100	RN30	31,4	M6	4,9

2.4.7.2 Supported bearing FF

The associated fixed bearing unit is the FK bearing series (page 120). The end machining suited to supported bearing FF is the E10-xx type (page 107).

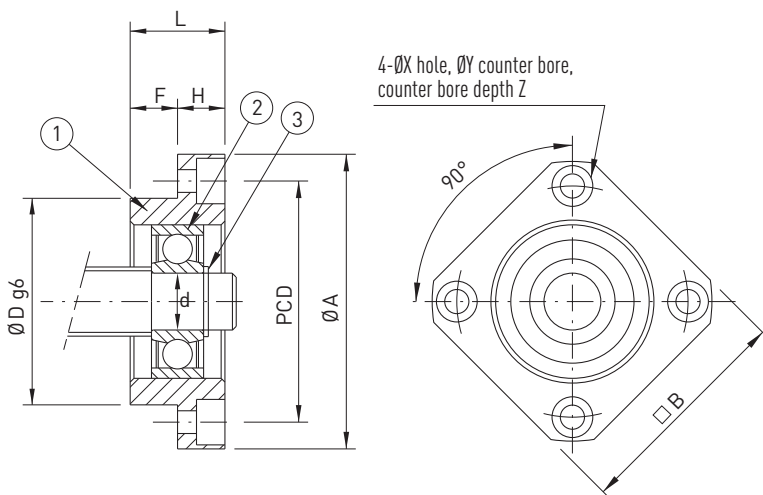

(1) Housing, (2) Bearing, (3) Circlip

Table 2.49 **Bearing unit dimensions**

Article number	Shaft nominal Ø	d	L	H	F	D g6	A	PCD	B	X	Y	Z	Bearing	Circlip
FF10	16	8	12	7	5	28	43	35	35	3,4	6,5	4,0	608ZZ	S 08
FF12	16*	10	15	7	8	34	52	42	42	4,5	8,0	4,0	6000ZZ	S 10
FF15	20	15	17	9	8	40	63	50	52	5,5	9,5	5,5	6002ZZ	S 15
FF20	25	20	20	11	9	57	85	70	68	6,6	11,0	6,5	6204ZZ	S 20
FF25	32	25	24	14	10	63	98	80	79	9,0	14,0	8,5	6205ZZ	S 25
FF30	40	30	27	18	9	75	117	95	93	11,0	17,0	11,0	6206ZZ	S 30

Unit: mm* depending on actual shaft outer diameter $d_{s \min} = 15,5$

Positioning Systems

KK Linear axes

3. Positioning Systems

3.1 KK Linear axes

3.1.1 Product overview KK linear axes

The HIWIN KK linear axes are compact positioning axes, which are supplied fully mounted with HIWIN servo motor and HIWIN servo drive. Alternatively, the KK linear axis can also be supplied with "motor-ready" mountings for connecting to customer-specific motors. High levels of accuracy and rigidity are achieved through a linear guideway in the steel profile with integrated ballscrew. The axis is available in different sizes and lengths and can be adapted to the relevant application requirements through additional options such as aluminium covers, bellow covers, limit switches and additional blocks.



3.1.2 Advantages of KK linear axes

- Ready-to-install complete axis with HIWIN servo motor and HIWIN drive
- Universal use
- Compact design
- Adaptable and robust
- High precision and rigidity

3.1.3 Construction of the linear axes KK

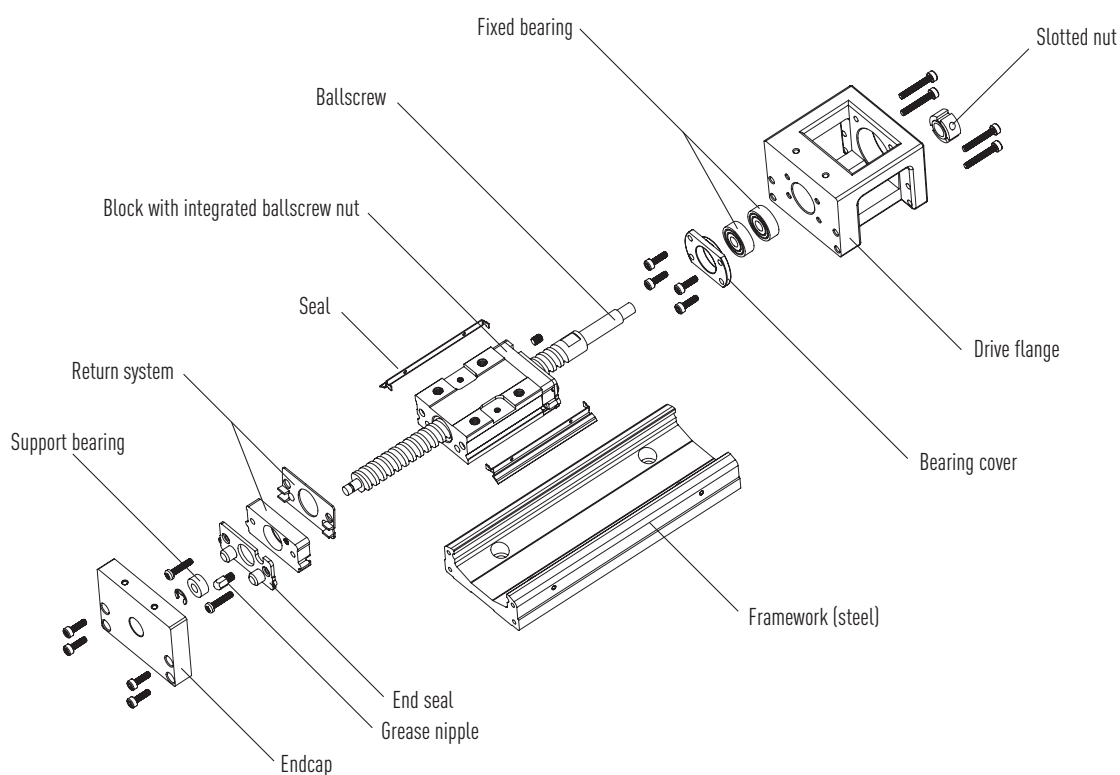

3.1.4 Order key for linear axes KK

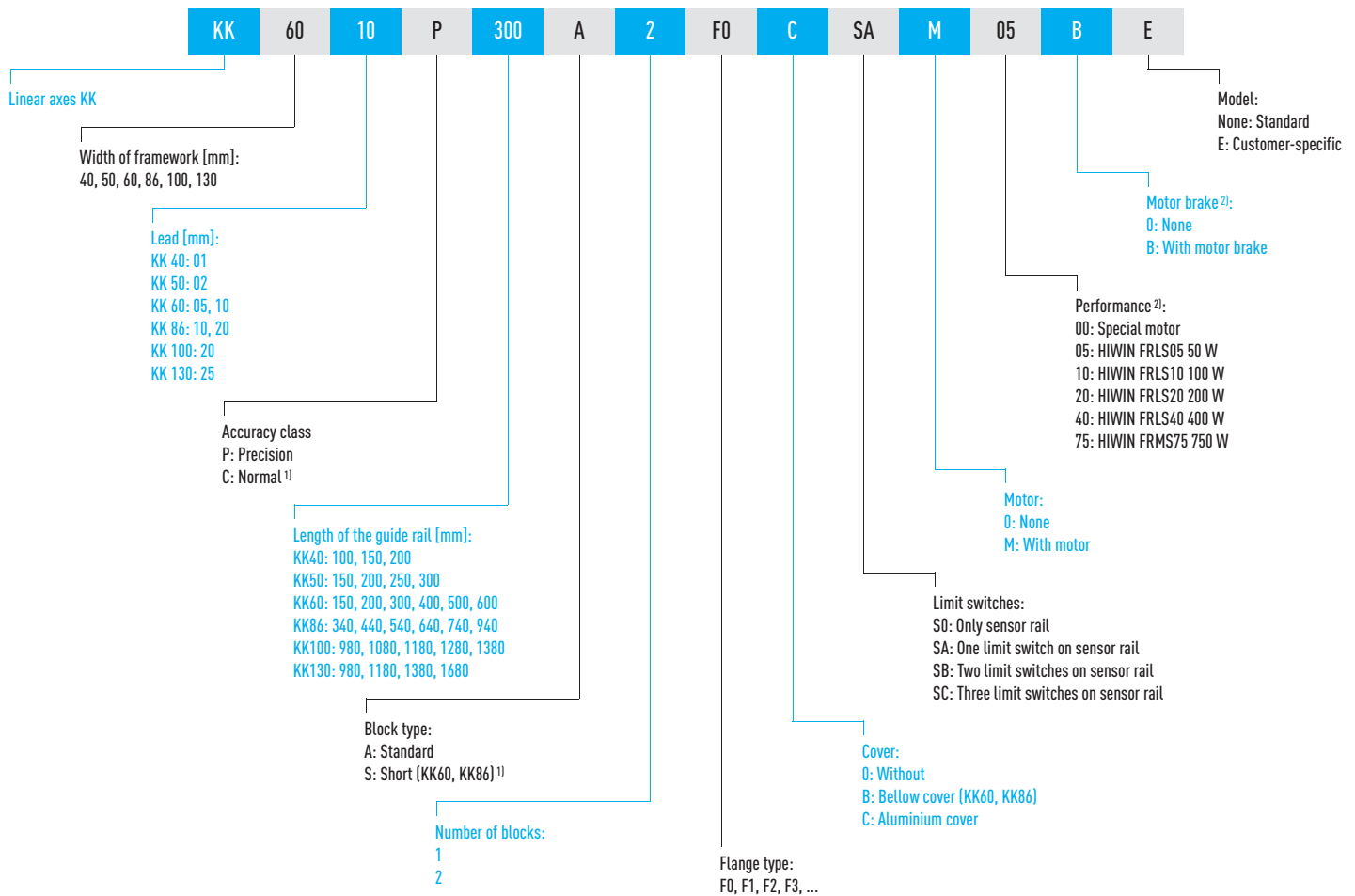

¹⁾ On request

²⁾ Not applicable for version without motor

The item numbers of the associated HIWIN servo motors and HIWIN drives and extension cables can be found in tables 3.73 and 3.74.

Table 3.50 Assignment of flange type to motor type

Motor output	Motor type	Flange type					
		KK40	KK50	KK60	KK86	KK100	KK130
50 W	FRLS05	F2	F2	F2	—	—	—
100 W	FRLS10	F2	F2	F2	—	—	—
200 W	FRLS20	—	—	—	F0	F0	F1
400 W	FRLS40	—	—	—	F0	F0	F1
750 W	FRMS75	—	—	—	—	F1	F0

Positioning Systems

KK Linear axes

3.1.5 Technical data of KK linear axes

Table 3.51 Technical data of KK linear axes

Model	Lead [mm]	L1 [mm]	v _{max} [mm/s]		a _{max} [m/s ²]	Accuracy [mm]	Repeatability [mm]	Guideway parallelism [mm]	Starting torque [Nmm]
			Without Motor	With motor					
KK4001P0100	1	159	190	75	5	0,020	± 0,003	0,010	12
KK4001P0150	1	209	190	75	5	0,020	± 0,003	0,010	12
KK4001P0200	1	259	190	75	5	0,020	± 0,003	0,010	12
KK5002P0150	2	220	270	150	5	0,020	± 0,003	0,010	40
KK5002P0200	2	270	270	150	5	0,020	± 0,003	0,010	40
KK5002P0250	2	320	270	150	5	0,020	± 0,003	0,010	40
KK5002P0300	2	370	270	150	5	0,020	± 0,003	0,010	150
KK6005P0150	5	220	550	375	15	0,020	± 0,003	0,010	150
KK6005P0200	5	270	550	375	15	0,020	± 0,003	0,010	150
KK6005P0300	5	370	550	375	15	0,020	± 0,003	0,010	150
KK6005P0400	5	470	550	375	15	0,020	± 0,003	0,010	150
KK6005P0500	5	570	550	375	15	0,020	± 0,003	0,010	150
KK6005P0600	5	670	340	340	15	0,025	± 0,003	0,015	150
KK6010P0150	10	220	1100	750	15	0,020	± 0,003	0,010	150
KK6010P0200	10	270	1100	750	15	0,020	± 0,003	0,010	150
KK6010P0300	10	370	1100	750	15	0,020	± 0,003	0,010	150
KK6010P0400	10	470	1100	750	15	0,020	± 0,003	0,010	150
KK6010P0500	10	570	1100	750	15	0,020	± 0,003	0,010	150
KK6010P0600	10	670	670	670	15	0,025	± 0,003	0,015	150
KK8610P0340	10	440	740	740	15	0,025	± 0,003	0,015	150
KK8610P0440	10	540	740	740	15	0,025	± 0,003	0,015	150
KK8610P0540	10	640	740	740	15	0,025	± 0,003	0,015	150
KK8610P0640	10	740	740	740	15	0,025	± 0,003	0,015	150
KK8610P0740	10	840	740	740	15	0,030	± 0,003	0,020	170
KK8610P0940	10	1040	610	610	15	0,040	± 0,003	0,030	250
KK8620P0340	20	440	1480	1480	15	0,025	± 0,003	0,015	150
KK8620P0440	20	540	1480	1480	15	0,025	± 0,003	0,015	150
KK8620P0540	20	640	1480	1480	15	0,025	± 0,003	0,015	150
KK8620P0640	20	740	1480	1480	15	0,025	± 0,003	0,015	150
KK8620P0740	20	840	1480	1480	15	0,030	± 0,003	0,020	170
KK8620P0940	20	1040	1220	1220	15	0,040	± 0,003	0,030	250
KK10020P0980	20	1089	1120	1120	15	0,035	± 0,005	0,025	170
KK10020P1080	20	1189	980	980	15	0,035	± 0,005	0,025	170
KK10020P1180	20	1289	750	750	15	0,040	± 0,005	0,030	200
KK10020P1280	20	1389	630	630	15	0,045	± 0,005	0,035	230
KK10020P1380	20	1489	530	530	15	0,050	± 0,005	0,040	250
KK13025P0980	25	1098	1120	1120	15	0,035	± 0,005	0,025	250
KK13025P1180	25	1298	1120	1120	15	0,040	± 0,005	0,030	250
KK13025P1380	25	1498	830	830	15	0,040	± 0,005	0,030	250
KK13025P1680	25	1798	550	550	15	0,050	± 0,007	0,040	270

Reference Side

When observed from the motor flange, the reference side is located on the left side of the linear module.

3.1.6 Load capacities of KK linear axes

Display of static moments affecting the KK linear axes.

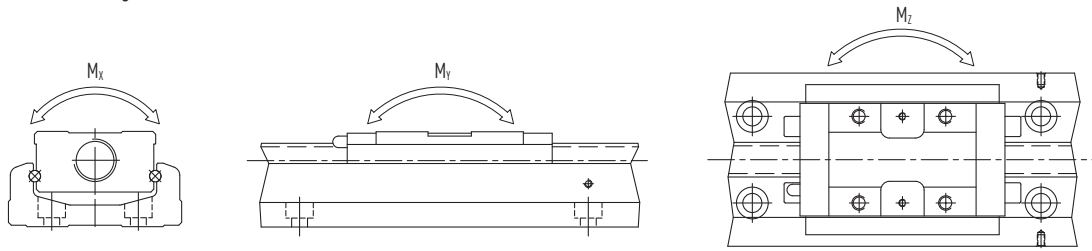

Table 3.52 Load capacity of KK linear axes: Guideway, standard block

Model	C_{dyn} [N]	C_0 [N]	Block A1			Block A2		
			M_x [Nm]	M_y [Nm]	M_z [Nm]	M_x [Nm]	M_y [Nm]	M_z [Nm]
KK40	3920	6468	81	33	33	162	182	182
KK50	8007	12916	222	116	116	444	545	545
KK60	13230	21462	419	152	152	838	760	760
KK86	31458	50764	1507	622	622	3014	3050	3050
KK100	39200	63406	2205	960	960	4410	4763	4763
KK130	48101	84829	3885	1536	1536	7770	7350	7350

Table 3.53 Load capacity of KK linear axes: Guideway, short block

Model	C_{dyn} [N]	C_0 [N]	Block S1			Block S2		
			M_x [Nm]	M_y [Nm]	M_z [Nm]	M_x [Nm]	M_y [Nm]	M_z [Nm]
KK60	7173	11574	241	72	72	482	367	367

Table 3.54 Load capacity of KK linear axes: Ballscrew and fixed bearing

Model	Shaft			Fixed side	
	\varnothing [mm]	C_{dyn} [N]	C_0 [N]	$C_{0 axial}$ [N]	$F_{max axial}$ [N]
KK4001Pxxxx	8	735	1538	1910	750
KK5002Pxxxx	8	2136	3489	1910	1500
KK6005Pxxxx	12	3744	6243	4480	3120
KK6010Pxxxx	12	2410	3743	4480	1870
KK8610Pxxxx	15	7144	12642	9240	6320
KK8620Pxxxx	15	4645	7655	9240	3825
KK10020Pxxxx	20	7046	12544	10600	6270
KK13025Pxxxx	25	7897	15931	18485	7950

Table 3.55 Area moment of inertia of KK linear axes

Model	Area moment of inertia [mm ⁴]	
	I_y	I_z
KK40	$3,533 \times 10^3$	$5,317 \times 10^4$
KK50	$9,600 \times 10^3$	$1,340 \times 10^5$
KK60	$2,056 \times 10^4$	$2,802 \times 10^5$
KK86	$7,445 \times 10^4$	$1,134 \times 10^6$
KK100	$1,296 \times 10^5$	$2,035 \times 10^6$
KK130	$2,546 \times 10^5$	$5,073 \times 10^6$

Positioning Systems

KK Linear axes

3.1.7 Linear axes KK40 without cover

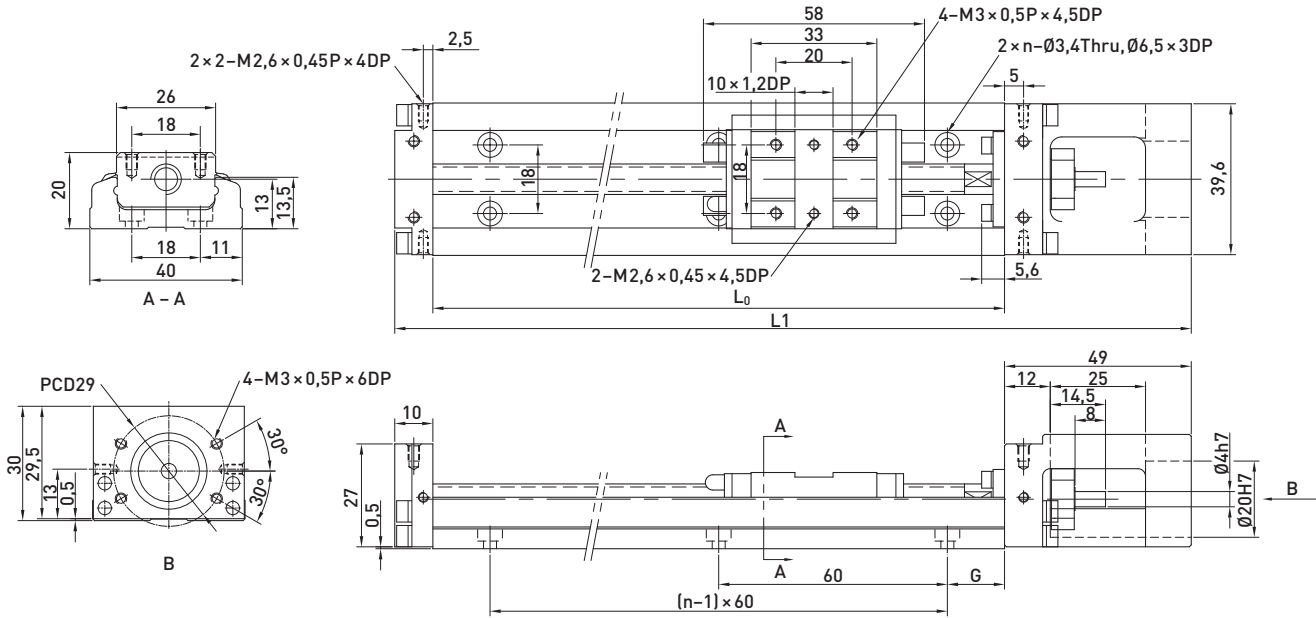

Table 3.56 Dimensions and mass of linear axes KK40 without cover

Model	Lead [mm]	L0 [mm]	L1 [mm]	Maximum stroke [mm]		G [mm]	K [mm]	n	m	Weight [kg]	
				Block A1	Block A2					Block A1	Block A2
KK4001P0100	1	100	159	36	—	20	—	2	—	0,48	—
KK4001P0150	1	150	209	86	34	15	—	3	—	0,6	0,67
KK4001P0200	1	200	259	136	84	40	—	3	—	0,72	0,79

Reference Side

When observed from the motor flange, the reference side is located on the left side of the linear module.

3.1.8 Linear axes KK40 with aluminium cover

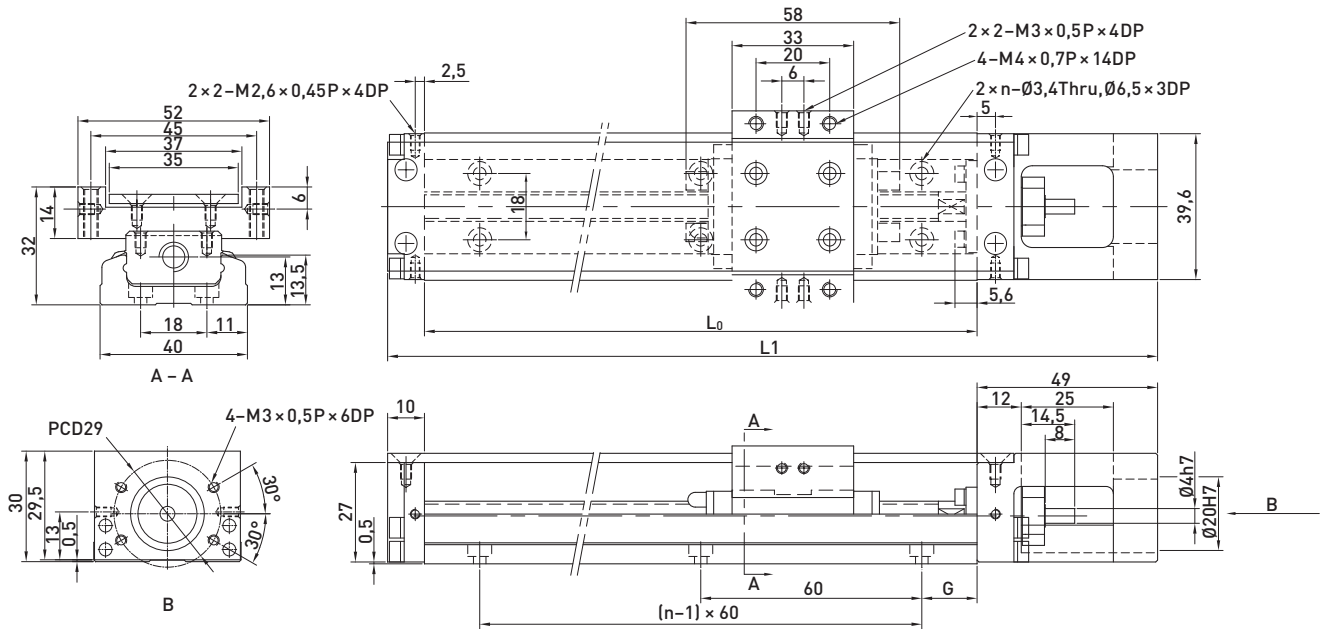

Table 3.57 Dimensions and mass of linear axes KK40 with aluminium cover

Model	Lead [mm]	L0 [mm]	L1 [mm]	Maximum stroke [mm]		G [mm]	K [mm]	n	m	Weight [kg]	
				Block A1	Block A2					Block A1	Block A2
KK4001P0100	1	100	159	36	—	20	—	2	—	0,55	—
KK4001P0150	1	150	209	86	34	15	—	3	—	0,68	0,76
KK4001P0200	1	200	259	136	84	40	—	3	—	0,82	0,89

Reference Side

When observed from the motor flange, the reference side is located on the left side of the linear module.

Positioning Systems

KK Linear axes

3.1.9 KK40 adapter flanges

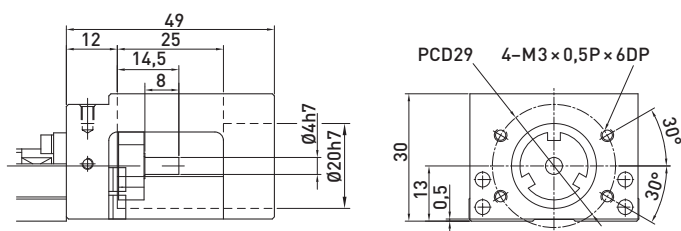

Adapter flange F0

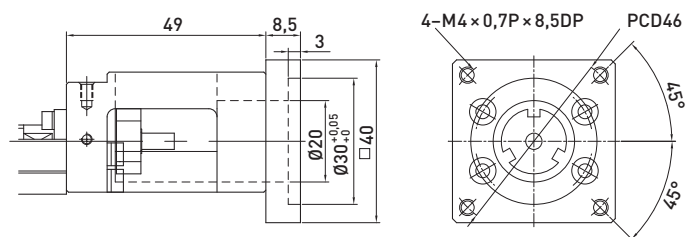

Adapter flange F1

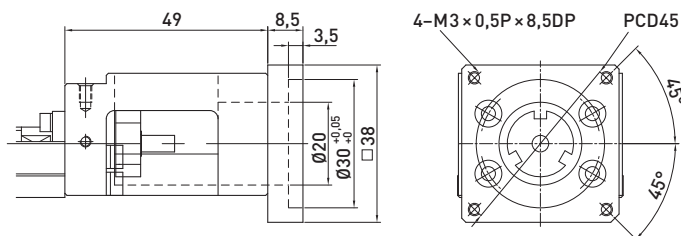

Adapter flange F2

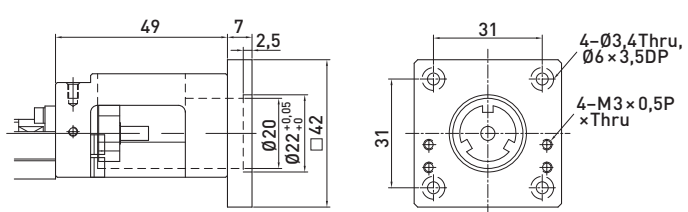

Adapter flange F3

3.1.10 Linear axes KK50 without cover

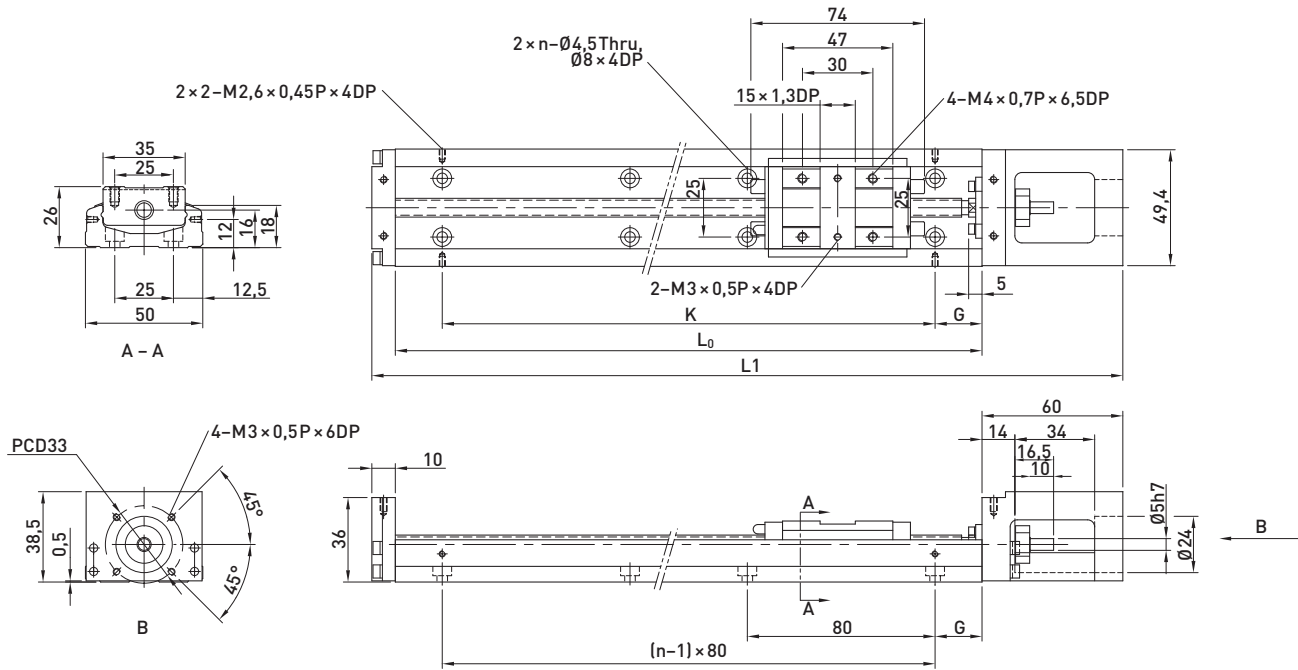

Table 3.58 Dimensions and mass of linear axes KK50 without cover

Model	Lead [mm]	L0 [mm]	L1 [mm]	Maximum stroke [mm]		G [mm]	K [mm]	n	m	Weight [kg]	
				Block A1	Block A2					Block A1	Block A2
KK5002P0150	2	150	220	70	—	35	80	2	—	1,0	—
KK5002P0200	2	200	270	120	55	20	160	3	—	1,2	1,4
KK5002P0250	2	250	320	170	105	45	160	3	—	1,4	1,6
KK5002P0300	2	300	370	220	155	30	240	4	—	1,6	1,8

Reference Side

When observed from the motor flange, the reference side is located on the left side of the linear module.

Positioning Systems

KK Linear axes

3.1.11 Linear axes KK50 with aluminium cover

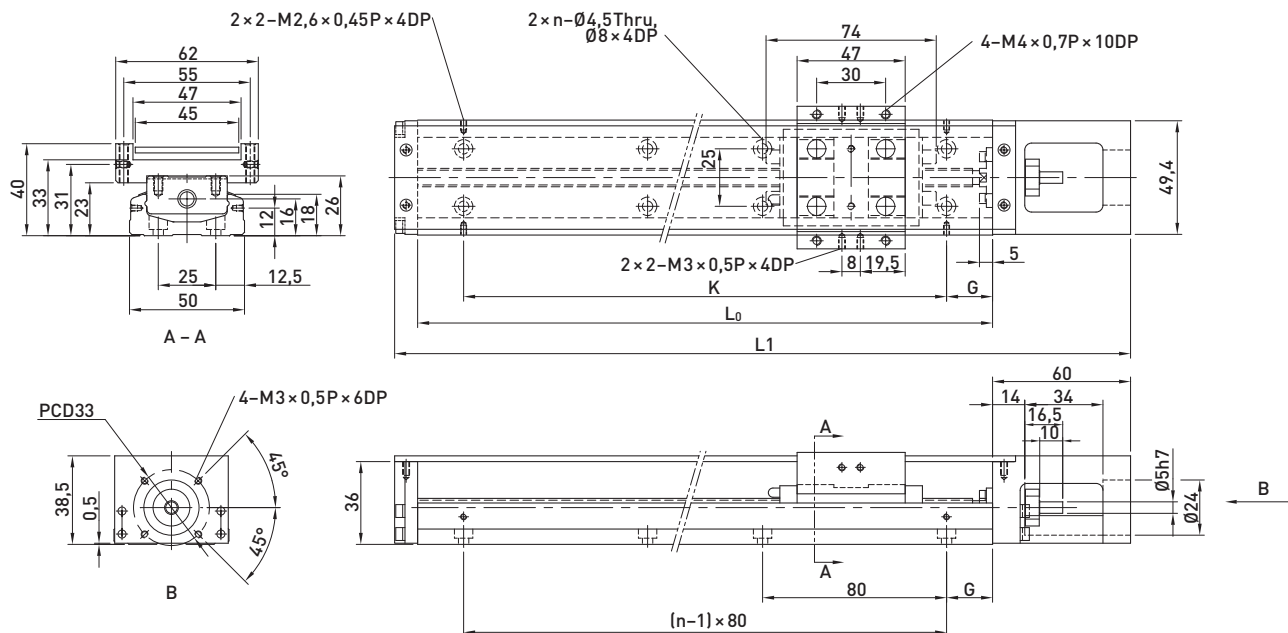

Table 3.59 Dimensions and mass of linear axes KK50 with aluminium cover

Model	Lead [mm]	L0 [mm]	L1 [mm]	Maximum stroke [mm]		G [mm]	K [mm]	n	m	Weight [kg]	
				Block A1	Block A2					Block A1	Block A2
KK5002P0150	2	150	220	70	—	35	80	2	—	1,1	—
KK5002P0200	2	200	270	120	55	20	160	3	—	1,3	1,5
KK5002P0250	2	250	320	170	105	45	160	3	—	1,6	1,8
KK5002P0300	2	300	370	220	155	30	240	4	—	1,8	2,0

Reference Side

When observed from the motor flange, the reference side is located on the left side of the linear module.

3.1.12 KK50 adapter flanges

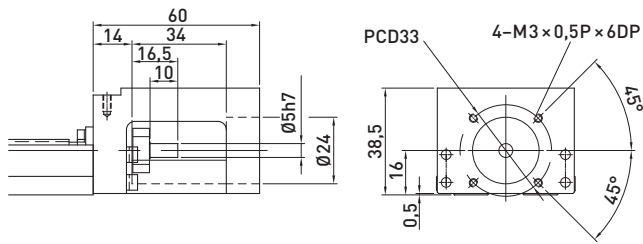

Adapter flange F0

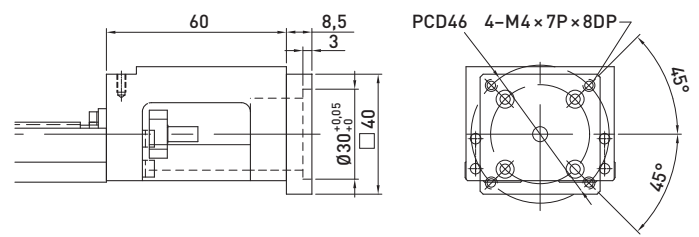

Adapter flange F1

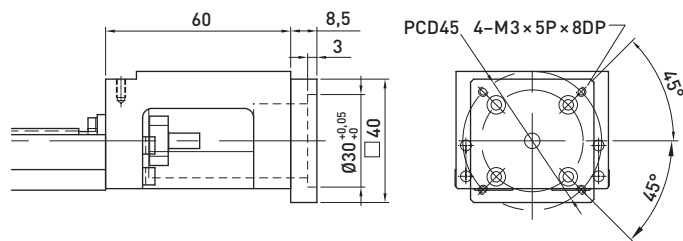

Adapter flange F2

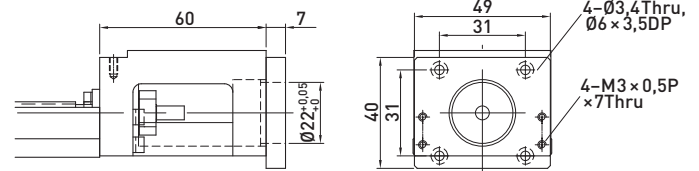

Adapter flange F3

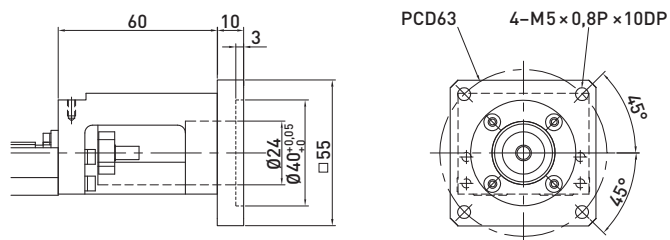

Adapter flange F4

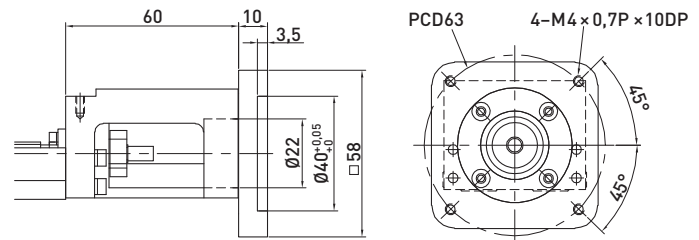

Adapter flange F5

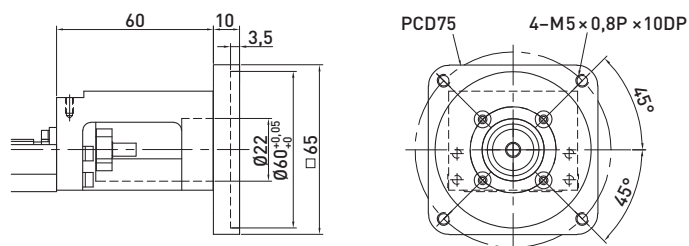

Adapter flange F6

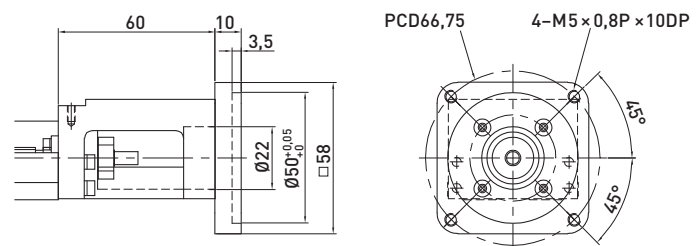

Adapter flange F7

Positioning Systems

KK Linear axes

3.1.13 Linear axes KK60 without cover, standard block

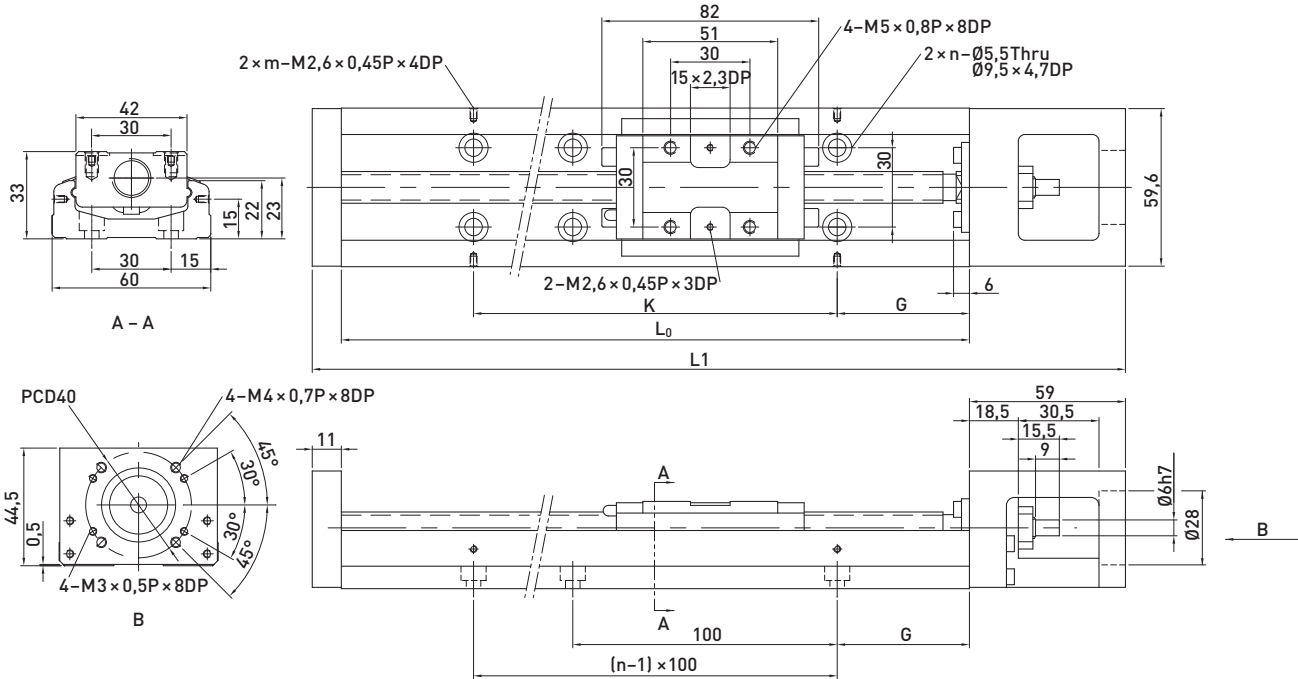

Table 3.60 Dimensions and mass of linear axes KK60 without cover, standard block

Model	Lead [mm]	L0 [mm]	L1 [mm]	Maximum stroke [mm]		G [mm]	K [mm]	n	m	Weight [kg]	
				Block A1	Block A2					Block A1	Block A2
KK6005P0150	5	150	220	60	—	25	100	2	2	1,5	—
KK6005P0200	5	200	270	110	—	50	100	2	2	1,8	—
KK6005P0300	5	300	370	210	135	50	200	3	2	2,4	2,7
KK6005P0400	5	400	470	310	235	50	100	4	4	3,0	3,3
KK6005P0500	5	500	570	410	335	50	200	5	3	3,6	3,9
KK6005P0600	5	600	670	510	435	50	100	6	6	4,2	4,6
KK6010P0150	10	150	220	60	—	25	100	2	2	1,5	—
KK6010P0200	10	200	270	110	—	50	100	2	2	1,8	—
KK6010P0300	10	300	370	210	135	50	200	3	2	2,4	2,7
KK6010P0400	10	400	470	310	235	50	100	4	4	3,0	3,3
KK6010P0500	10	500	570	410	335	50	200	5	3	3,6	3,9
KK6010P0600	10	600	670	510	435	50	100	6	6	4,2	4,6

Reference Side

When observed from the motor flange, the reference side is located on the left side of the linear module.

3.1.14 Linear axes KK60 without cover, short block

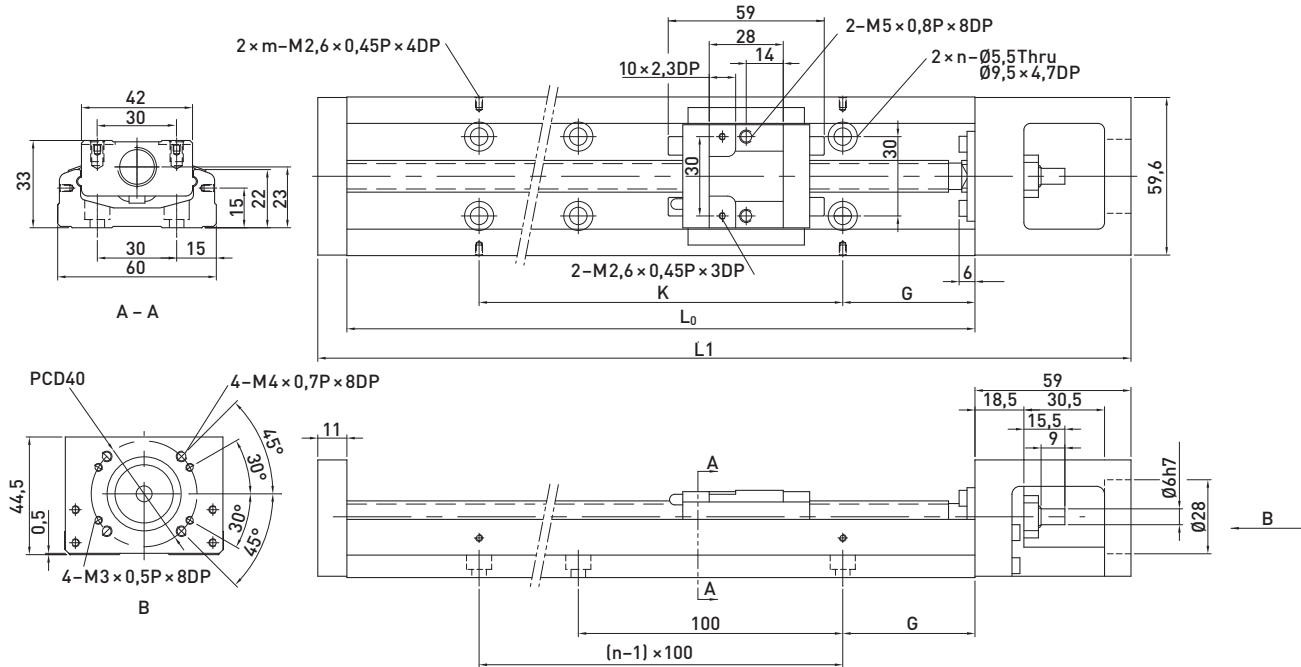

Table 3.61 Dimensions and mass of linear axes KK60 without cover, short block

Model	Lead [mm]	L0 [mm]	L1 [mm]	Maximum stroke [mm]		G [mm]	K [mm]	n	m	Weight [kg]	
				Block A1	Block A2					Block A1	Block A2
KK6005P0150	5	150	220	85	34	25	100	2	2	1,4	1,6
KK6005P0200	5	200	270	135	84	50	100	2	2	1,7	1,9
KK6005P0300	5	300	370	235	184	50	200	3	2	2,3	2,5
KK6005P0400	5	400	470	335	284	50	100	4	4	2,9	3,1
KK6005P0500	5	500	570	435	384	50	200	5	3	3,5	3,7
KK6005P0600	5	600	670	535	484	50	100	6	6	4,1	4,3
KK6010P0150	10	150	220	85	34	25	100	2	2	1,4	1,6
KK6010P0200	10	200	270	135	84	50	100	2	2	1,7	1,9
KK6010P0300	10	300	370	235	184	50	200	3	2	2,3	2,5
KK6010P0400	10	400	470	335	284	50	100	4	4	2,9	3,1
KK6010P0500	10	500	570	435	384	50	200	5	3	3,5	3,7
KK6010P0600	10	600	670	535	484	50	100	6	6	4,1	4,3

Reference Side

When observed from the motor flange, the reference side is located on the left side of the linear module.

Positioning Systems

KK Linear axes

3.1.15 Linear axes KK60 with aluminium cover, standard block

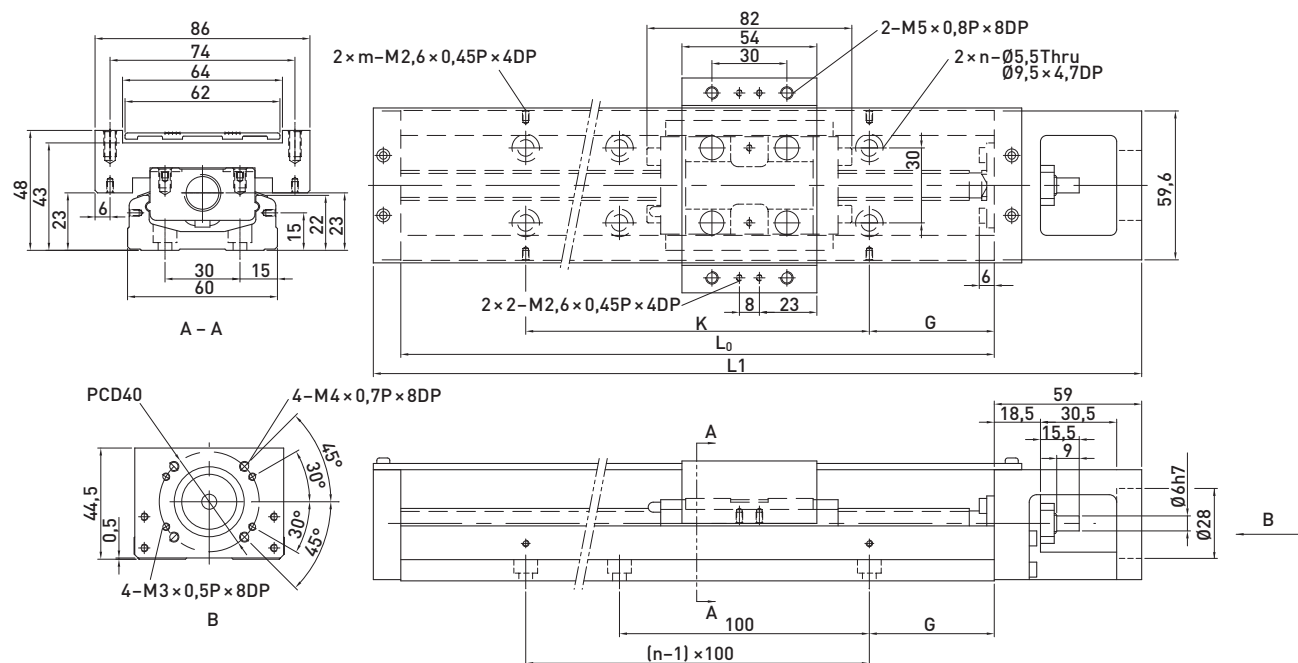

Table 3.62 Dimensions and mass of linear axes KK60 with cover, standard block

Model	Lead [mm]	L0 [mm]	L1 [mm]	Maximum stroke [mm]		G [mm]	K [mm]	n	m	Weight [kg]	
				Block A1	Block A2					Block A1	Block A2
				KK6005P0150	5					150	220
KK6005P0200	5	200	270	110	—	50	100	2	2	2,1	—
KK6005P0300	5	300	370	210	135	50	200	3	2	2,7	3,0
KK6005P0400	5	400	470	310	235	50	100	4	4	3,3	3,6
KK6005P0500	5	500	570	410	335	50	200	5	3	3,9	4,2
KK6005P0600	5	600	670	510	435	50	100	6	6	4,4	5,0
KK6010P0150	10	150	220	60	—	25	100	2	2	1,7	—
KK6010P0200	10	200	270	110	—	50	100	2	2	2,1	—
KK6010P0300	10	300	370	210	135	50	200	3	2	2,7	3,0
KK6010P0400	10	400	470	310	235	50	100	4	4	3,3	3,6
KK6010P0500	10	500	570	410	335	50	200	5	3	3,9	4,2
KK6010P0600	10	600	670	510	435	50	100	6	6	4,4	5,0

Reference Side

When observed from the motor flange, the reference side is located on the left side of the linear module.

3.1.16 Linear axes KK60 with aluminium cover, short block

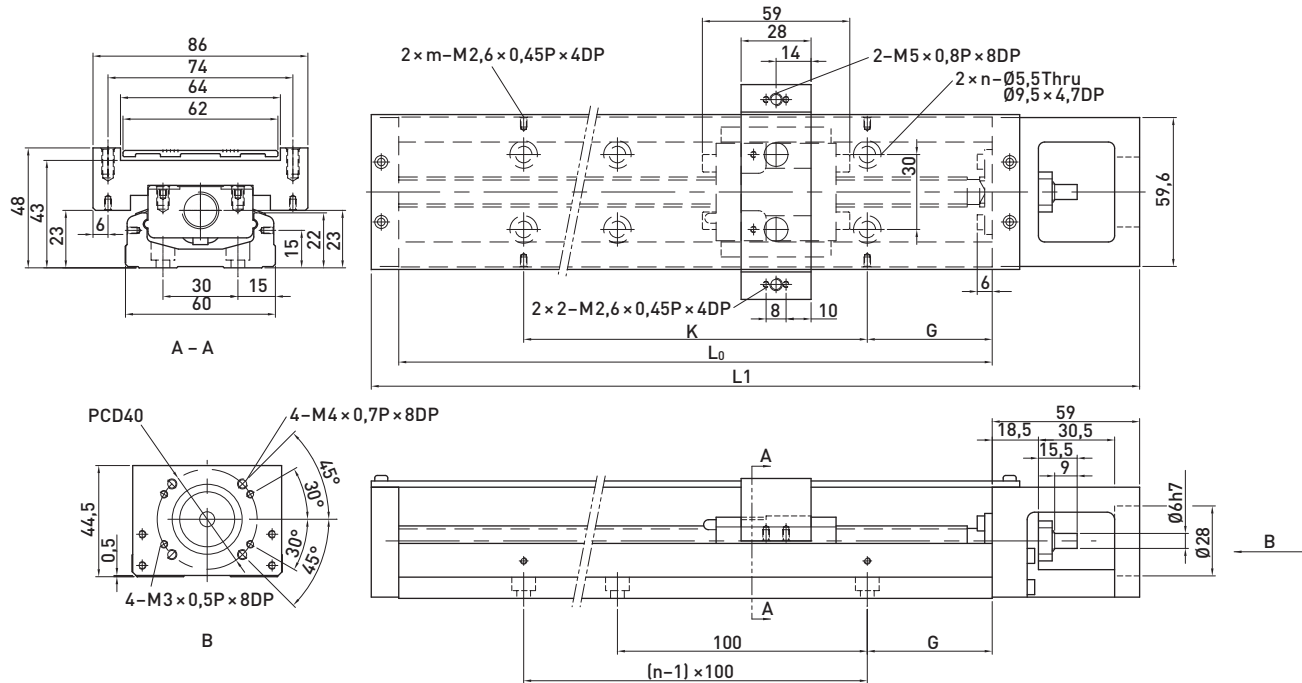

Table 3.63 Dimensions and mass of linear axes KK60 with cover, short block

Model	Lead [mm]	L0 [mm]	L1 [mm]	Maximum stroke [mm]		G [mm]	K [mm]	n	m	Weight [kg]	
				Block A1	Block A2					Block A2	Block A1
KK6005P0150	5	150	220	85	34	25	100	2	2	1,8	1,6
KK6005P0200	5	200	270	135	84	50	100	2	2	2,1	1,9
KK6005P0300	5	300	370	235	184	50	200	3	2	2,7	2,5
KK6005P0400	5	400	470	335	284	50	100	4	4	3,3	3,1
KK6005P0500	5	500	570	435	384	50	200	5	3	3,9	3,7
KK6005P0600	5	600	670	535	484	50	100	6	6	4,6	4,4
KK6010P0150	10	150	220	85	34	25	100	2	2	1,8	1,6
KK6010P0200	10	200	270	135	84	50	100	2	2	2,1	1,9
KK6010P0300	10	300	370	235	184	50	200	3	2	2,7	2,5
KK6010P0400	10	400	470	335	284	50	100	4	4	3,3	3,1
KK6010P0500	10	500	570	435	384	50	200	5	3	3,9	3,7
KK6010P0600	10	600	670	535	484	50	100	6	6	4,6	4,4

Reference Side

When observed from the motor flange, the reference side is located on the left side of the linear module.

Positioning Systems

KK Linear axes

3.1.17 Linear axes KK60 with bellow cover

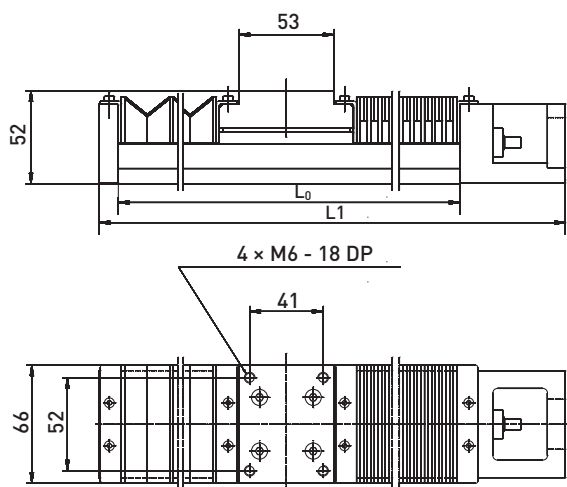
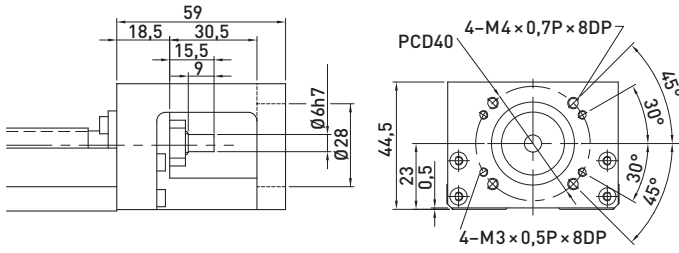

Table 3.64 Dimensions and mass of linear axes KK60 with bellow cover

Model	Lead [mm]	L0 [mm]	L1 [mm]	Maximum stroke [mm]	Weight [kg]
KK6005P0150	5	150	220	45	1,7
KK6005P0200	5	200	270	77	2,1
KK6005P0300	5	300	370	151	2,7
KK6005P0400	5	400	470	230	3,3
KK6005P0500	5	500	570	300	3,9
KK6005P0600	5	600	670	376	4,6
KK6010P0150	10	150	220	45	1,7
KK6010P0200	10	200	270	77	2,1
KK6010P0300	10	300	370	151	2,7
KK6010P0400	10	400	470	230	3,3
KK6010P0500	10	500	570	300	3,9
KK6010P0600	10	600	670	376	4,6

3.1.18 KK60 adapter flanges



Adapter flange F0

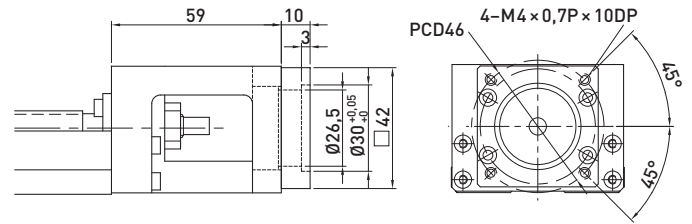

Adapter flange F1

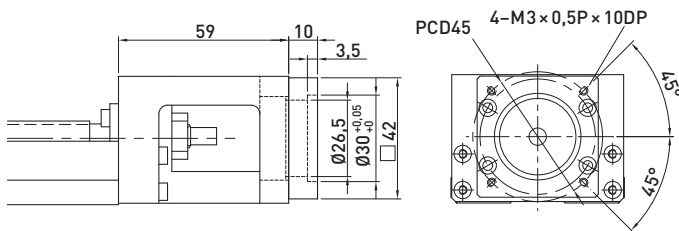

Adapter flange F2

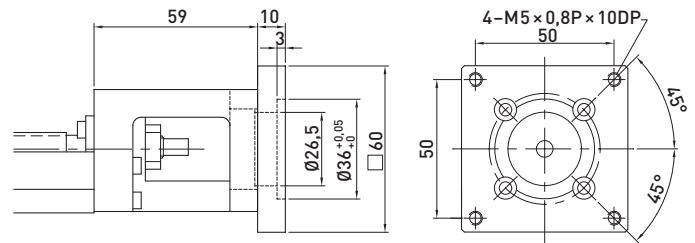

Adapter flange F3

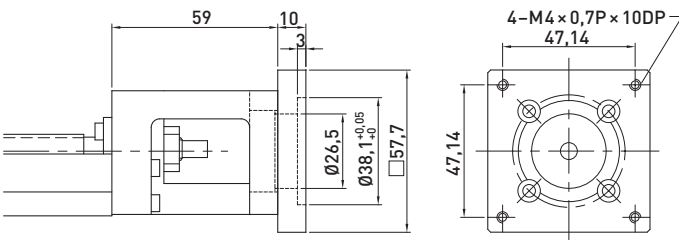

Adapter flange F4

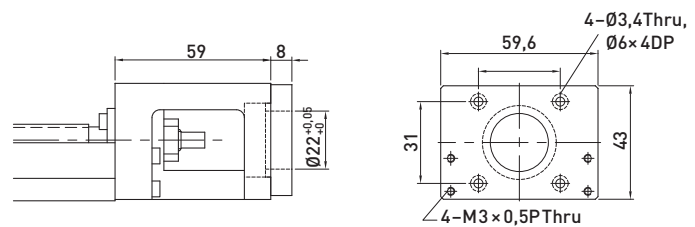

Adapter flange F5

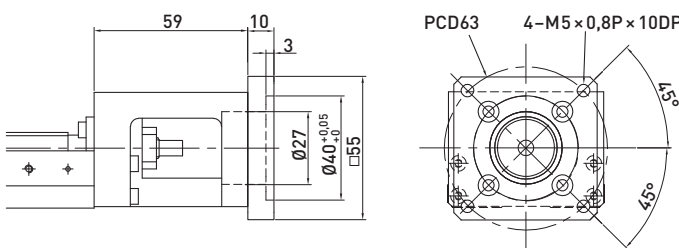

Adapter flange F6

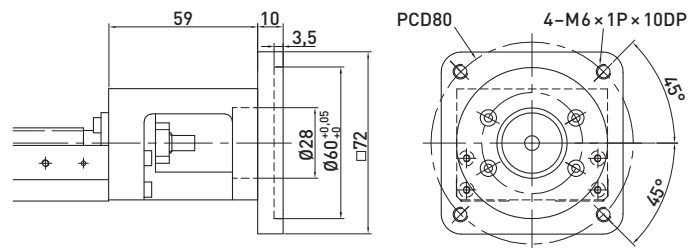

Adapter flange F7

Positioning Systems

KK Linear axes

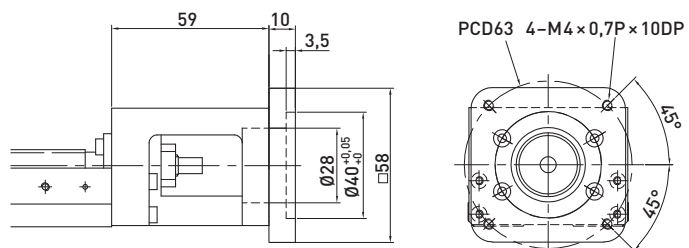

Adapter flange F8

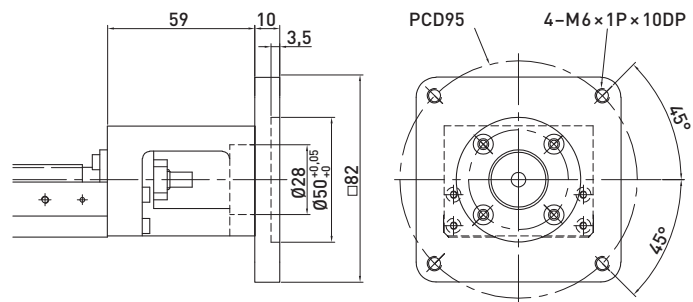

Adapter flange F9

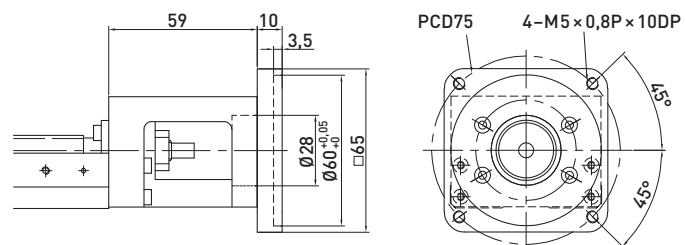

Adapter flange F10

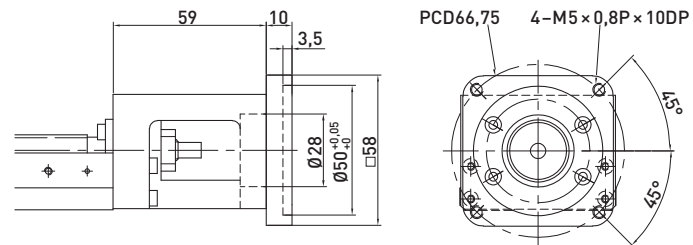

Adapter flange F11

3.1.19 Linear axes KK86 without cover

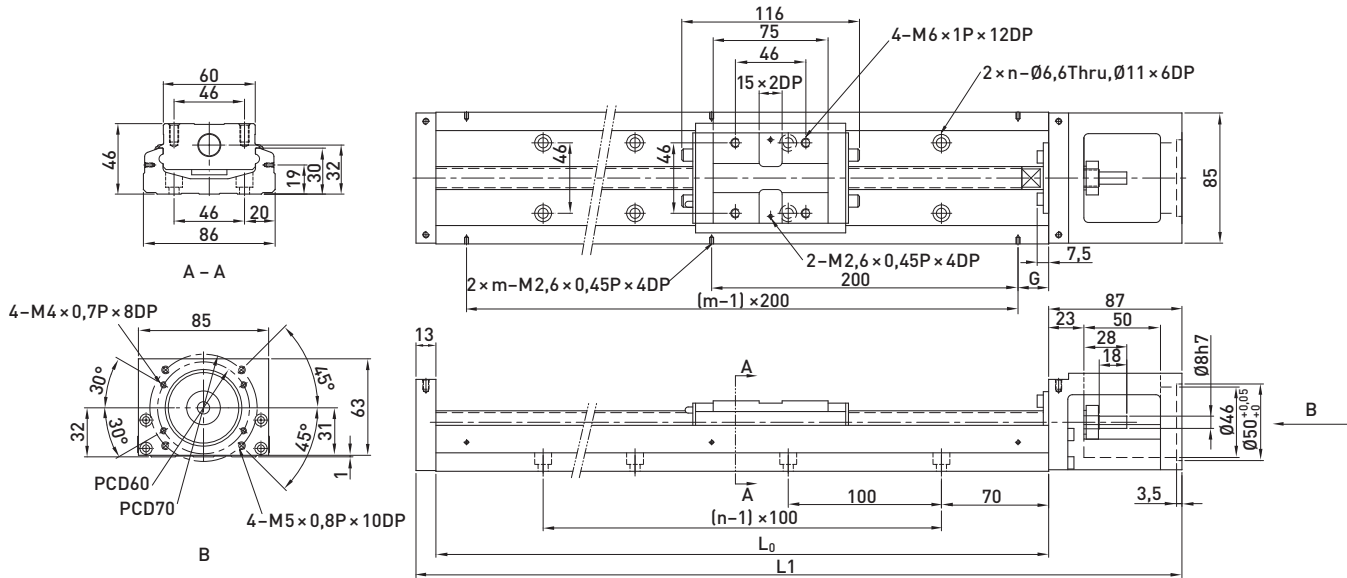

Table 3.65 Dimensions and mass of linear axes KK86 without cover

Model	Lead [mm]	L0 [mm]	L1 [mm]	Maximum stroke [mm]		G [mm]	K [mm]	n	m	Weight [kg]	
				Block A1	Block A2					Block A1	Block A2
KK8610P0340	10	340	440	210	100	70	—	3	2	5,7	6,5
KK8610P0440	10	440	540	310	200	20	—	4	3	6,9	7,7
KK8610P0540	10	540	640	410	300	70	—	5	3	8,0	8,8
KK8610P0640	10	640	740	510	400	20	—	6	4	9,2	10,0
KK8610P0740	10	740	840	610	500	70	—	7	4	10,4	11,2
KK8610P0940	10	940	1040	810	700	70	—	9	5	11,6	12,4
KK8620P0340	20	340	440	210	100	70	—	3	2	5,7	6,5
KK8620P0440	20	440	540	310	200	20	—	4	3	6,9	7,7
KK8620P0540	20	540	640	410	300	70	—	5	3	8,0	8,8
KK8620P0640	20	640	740	510	400	20	—	6	4	9,2	10,0
KK8620P0740	20	740	840	610	500	70	—	7	4	10,4	11,2
KK8620P0940	20	940	1040	810	700	70	—	9	5	11,6	12,4

Reference Side

When observed from the motor flange, the reference side is located on the left side of the linear module.

Positioning Systems

KK Linear axes

3.1.20 Linear axes KK86 with aluminium cover

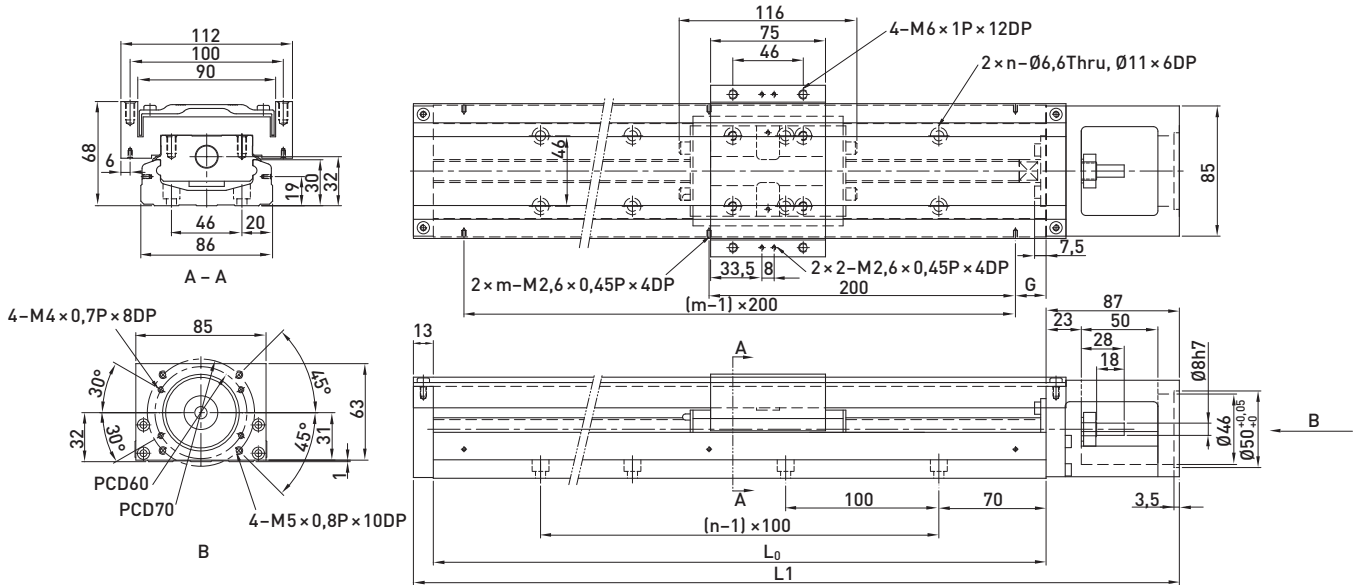

Table 3.66 Dimensions and mass of linear axes KK86 with aluminium cover

Model	Lead [mm]	L0 [mm]	L1 [mm]	Maximum stroke [mm]		G [mm]	K [mm]	n	m	Weight [kg]	
				Block A1	Block A2					Block A1	Block A2
KK8610P0340	10	340	440	210	100	70	—	3	2	6,5	7,3
KK8610P0440	10	440	540	310	200	20	—	4	3	7,8	8,6
KK8610P0540	10	540	640	410	300	70	—	5	3	9,0	9,8
KK8610P0640	10	640	740	510	400	20	—	6	4	10,3	11,3
KK8610P0740	10	740	840	610	500	70	—	7	4	11,6	12,4
KK8610P0940	10	940	1040	810	700	70	—	9	5	13,0	13,8
KK8620P0340	20	340	440	210	100	70	—	3	2	6,5	7,3
KK8620P0440	20	440	540	310	200	20	—	4	3	7,8	8,6
KK8620P0540	20	540	640	410	300	70	—	5	3	9,0	9,8
KK8620P0640	20	640	740	510	400	20	—	6	4	10,3	11,3
KK8620P0740	20	740	840	610	500	70	—	7	4	11,6	12,4
KK8620P0940	20	940	1040	810	700	70	—	9	5	13,0	13,8

Reference Side

When observed from the motor flange, the reference side is located on the left side of the linear module.

3.1.21 Linear axes KK86 with bellow cover

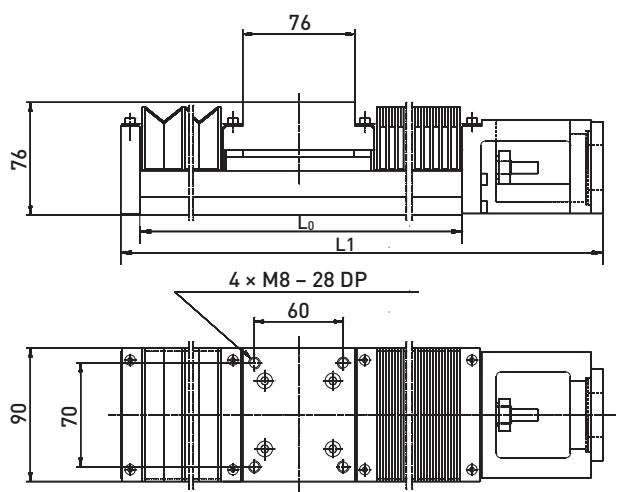

Table 3.67 Dimensions and mass of linear axes KK86 with bellow cover

Model	Lead [mm]	L0 [mm]	L1 [mm]	Maximum stroke [mm]	Weight [kg]
KK8610P0340	10	340	440	174	6,3
KK8610P0440	10	440	540	248	7,6
KK8610P0540	10	540	640	327	8,8
KK8610P0640	10	640	740	410	10,0
KK8610P0740	10	740	840	491	11,3
KK8610P0940	10	940	1040	654	12,7
KK8620P0340	20	340	440	174	6,3
KK8620P0440	20	440	540	248	7,6
KK8620P0540	20	540	640	327	8,8
KK8620P0640	20	640	740	410	10,0
KK8620P0740	20	740	840	491	11,3
KK8620P0940	20	940	1040	654	12,7

Positioning Systems

KK Linear axes

3.1.22 KK86 adapter flanges

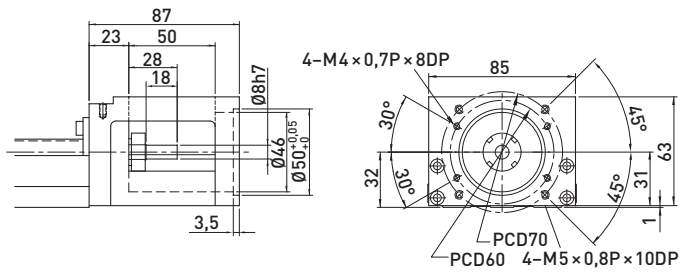

Adapter flange F0

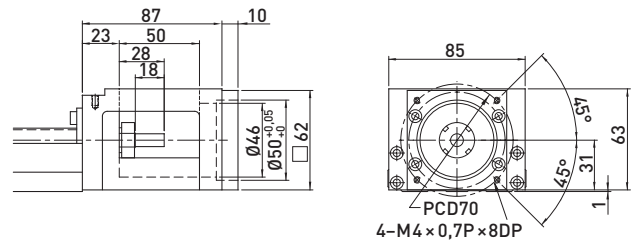

Adapter flange F1

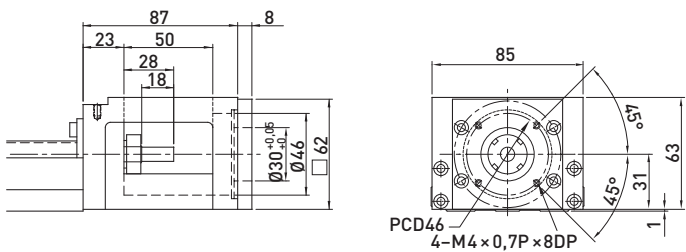

Adapter flange F2

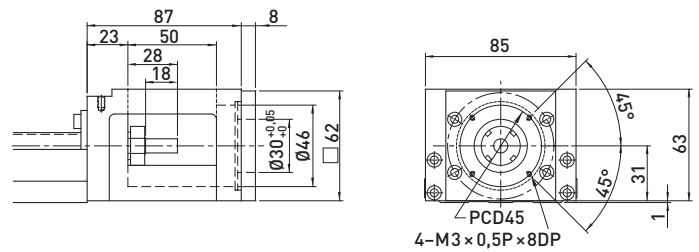

Adapter flange F3

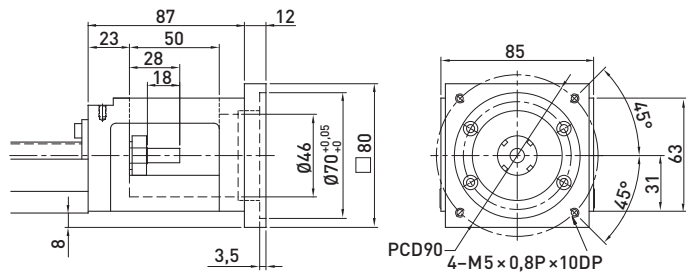

Adapter flange F4

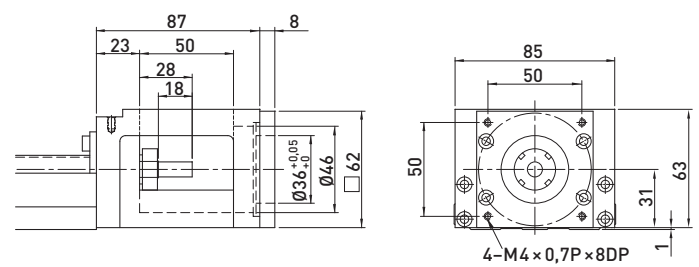

Adapter flange F5

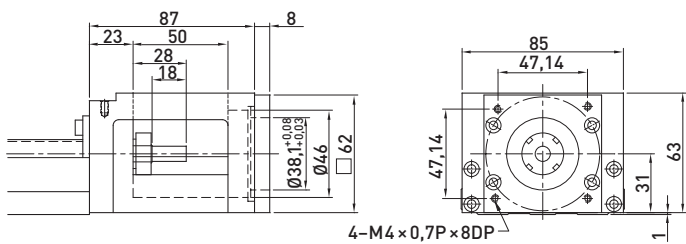

Adapter flange F6

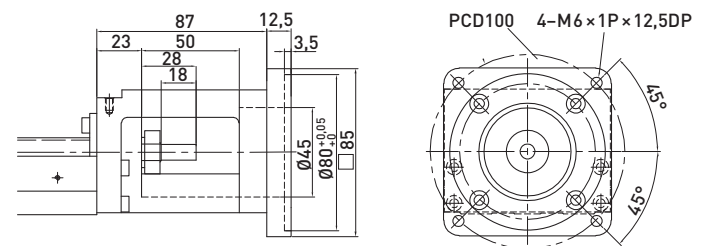

Adapter flange F7

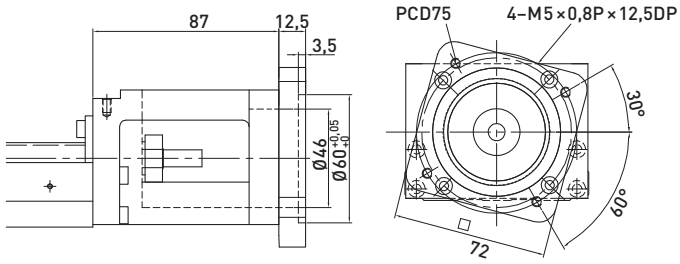

Adapter flange F8

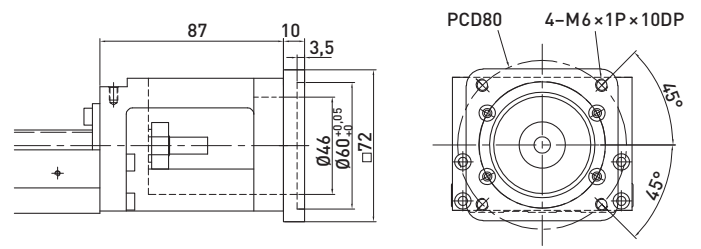

Adapter flange F9

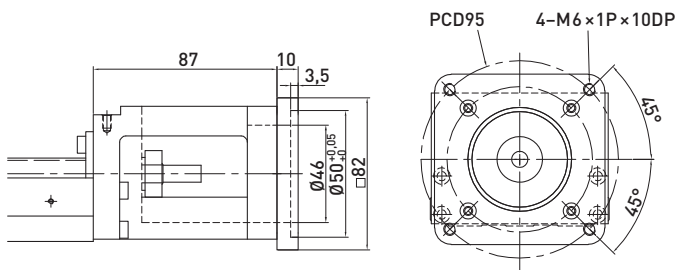

Adapter flange F10

Positioning Systems

KK Linear axes

3.1.23 Linear axes KK100 without cover

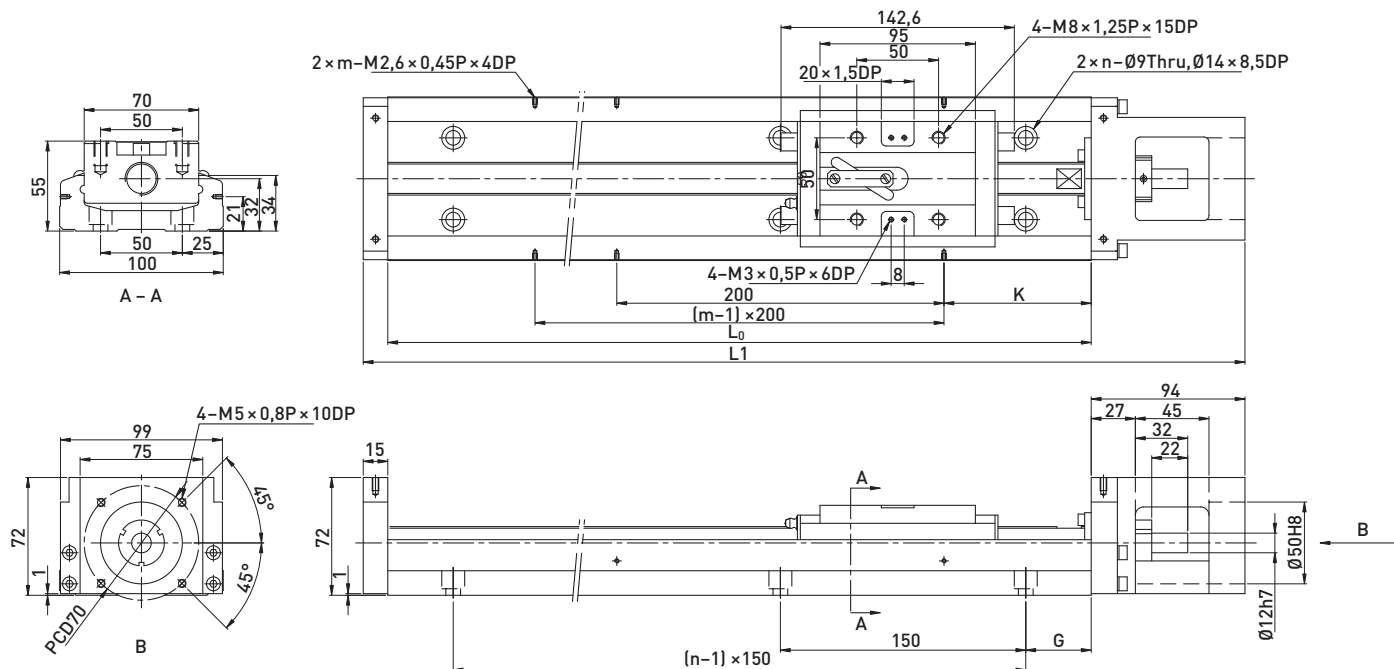

Table 3.68 Dimensions and mass of linear axes KK100 without cover

Model	Lead [mm]	L0 [mm]	L1 [mm]	Maximum stroke [mm]		G [mm]	K [mm]	n	m	Weight [kg]	
				Block A1	Block A2					Block A1	Block A2
KK10020P0980	20	980	1089	828	700	40	90	7	5	18,6	20,3
KK10020P1080	20	1080	1189	928	800	15	40	8	6	20,3	22,0
KK10020P1180	20	1180	1289	1028	900	65	90	8	6	22,0	23,7
KK10020P1280	20	1280	1389	1128	1000	40	40	9	7	23,6	25,3
KK10020P1380	20	1380	1489	1228	1100	15	90	10	7	25,3	27,0

Reference Side

When observed from the motor flange, the reference side is located on the left side of the linear module.

3.1.24 Linear axes KK100 with aluminium cover

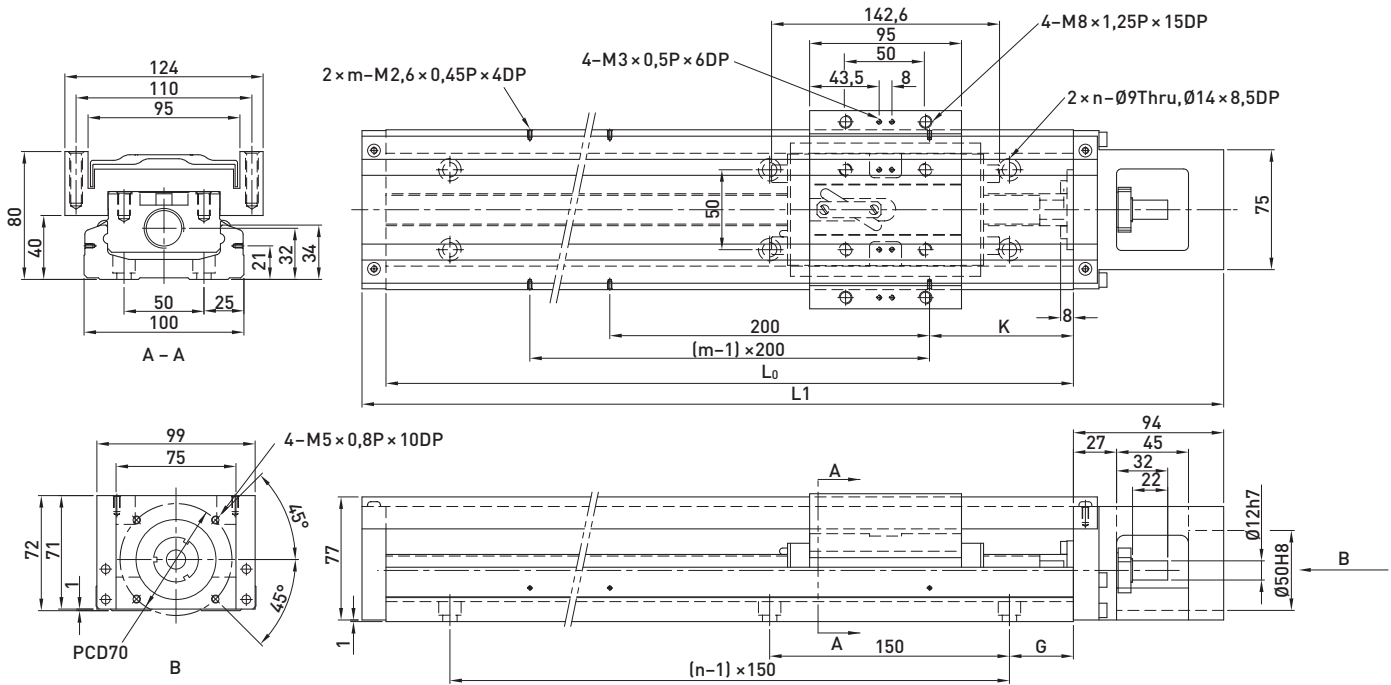

Table 3.69 Dimensions and mass of linear axes KK100 with aluminium cover

Model	Lead [mm]	L0 [mm]	L1 [mm]	Maximum stroke [mm]		G [mm]	K [mm]	n	m	Weight [kg]	
				Block A1	Block A2					Block A1	Block A2
KK10020P0980	20	980	1089	828	700	40	90	7	5	20,4	22,1
KK10020P1080	20	1080	1189	928	800	15	40	8	6	22,2	23,9
KK10020P1180	20	1180	1289	1028	900	65	90	8	6	24,0	25,7
KK10020P1280	20	1280	1389	1128	1000	40	40	9	7	25,7	27,4
KK10020P1380	20	1380	1489	1228	1100	15	90	10	7	27,5	29,2

Reference Side

When observed from the motor flange, the reference side is located on the left side of the linear module.

Positioning Systems

KK Linear axes

3.1.25 KK100 adapter flanges

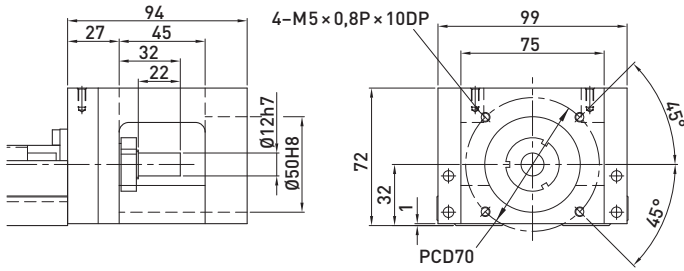

Adapter flange F0

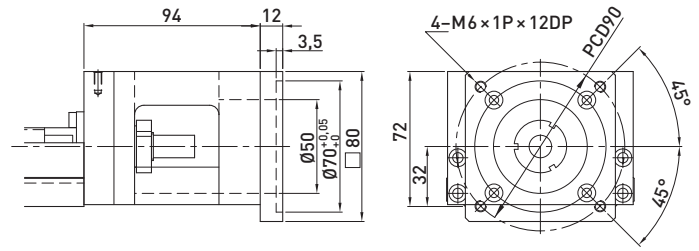

Adapter flange F1

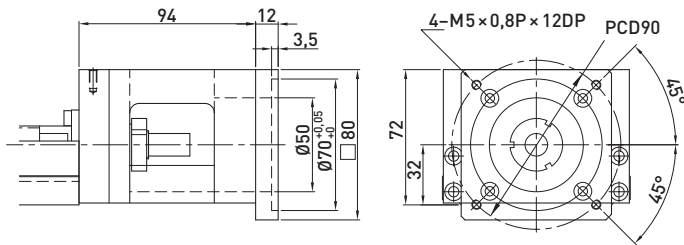

Adapter flange F2

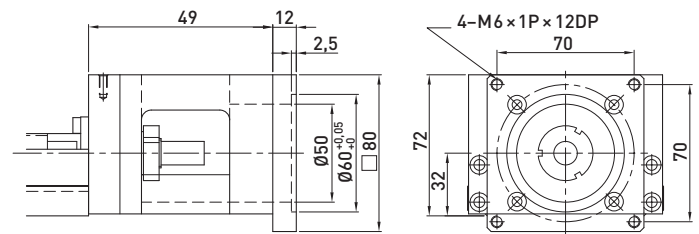

Adapter flange F3

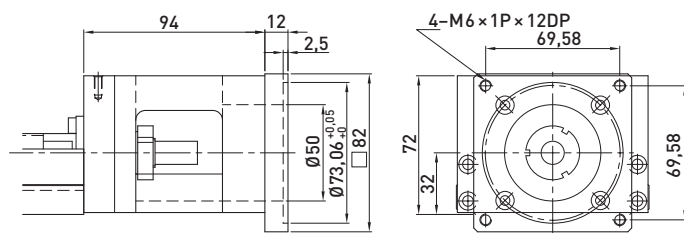

Adapter flange F4

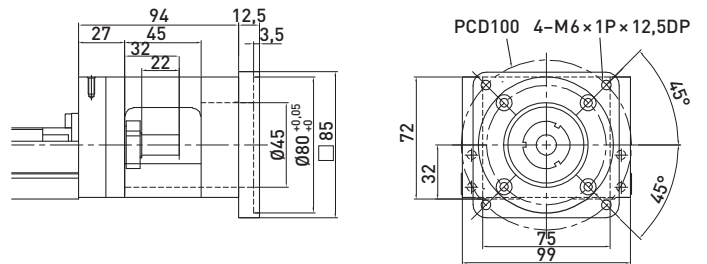

Adapter flange F5

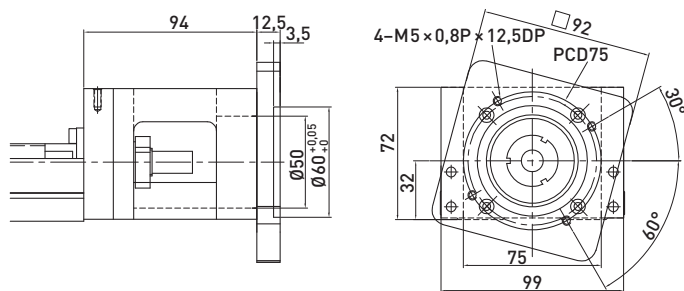

Adapter flange F6

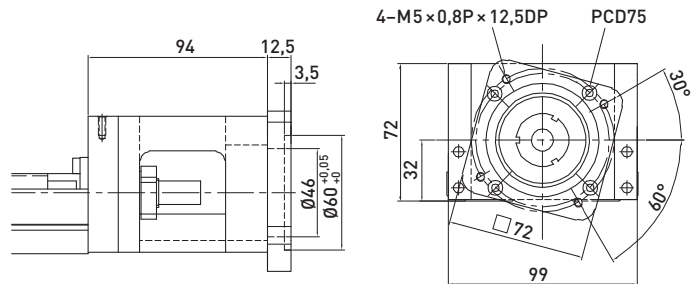

Adapter flange F7

3.1.26 Linear axes KK130 without cover

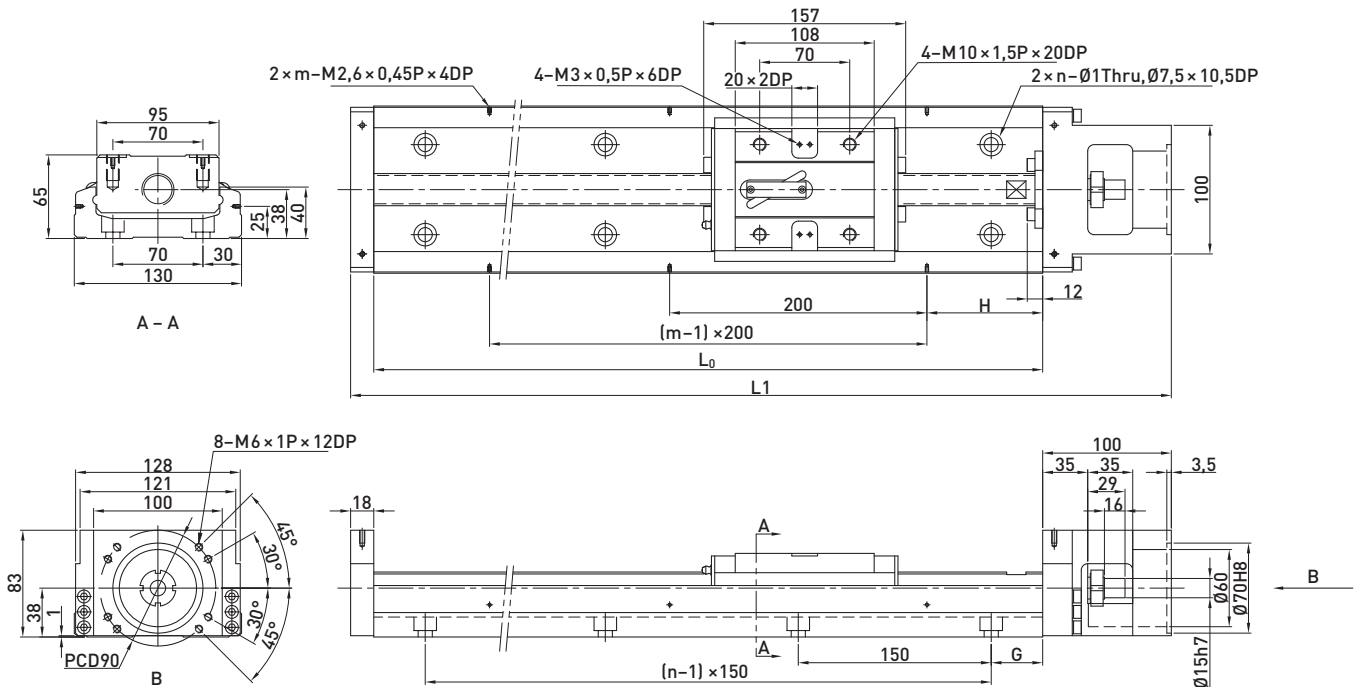

Table 3.70 Dimensions and mass of linear axes KK130 without cover

Model	Lead [mm]	L0 [mm]	L1 [mm]	Maximum stroke [mm]		G [mm]	K [mm]	n	m	Weight [kg]	
				Block A1	Block A2					Block A1	Block A2
KK13025P0980	25	980	1098	811	659	40	90	7	5	29,4	32,3
KK13025P1180	25	1180	1298	1011	859	65	90	8	6	34,3	37,2
KK13025P1380	25	1380	1498	1211	1059	90	90	9	7	39,2	42,1
KK13025P1680	25	1680	1798	1511	1359	90	40	11	9	46,5	49,4

Reference Side

When observed from the motor flange, the reference side is located on the left side of the linear module.

Positioning Systems

KK Linear axes

3.1.27 Linear axes KK130 with aluminium cover

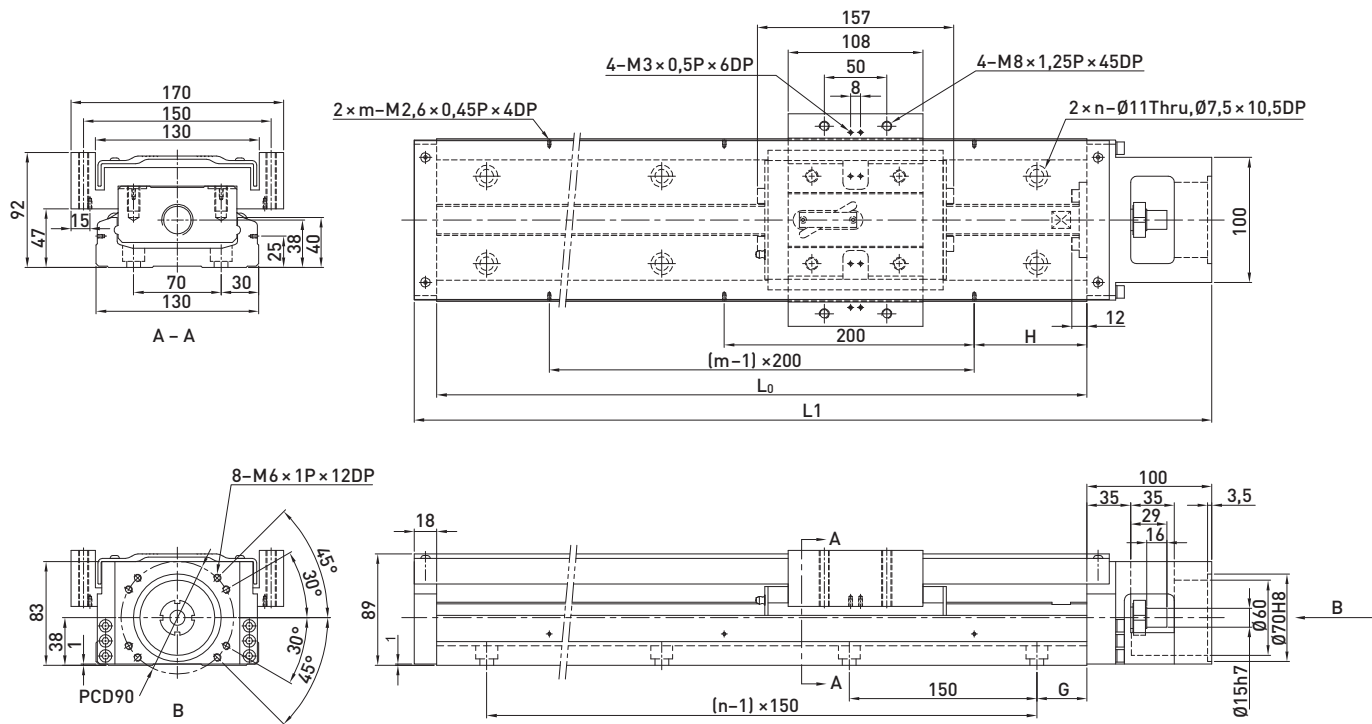

Table 3.71 Dimensions and mass of linear axes KK130 with aluminium cover

Model	Lead [mm]	L0 [mm]	L1 [mm]	Maximum stroke [mm]		G [mm]	K [mm]	n	m	Weight [kg]	
				Block A1	Block A2					Block A1	Block A2
KK13025P0980	25	980	1098	811	659	40	90	7	5	31,9	35,9
KK13025P1180	25	1180	1298	1011	859	65	90	8	6	37,1	41,1
KK13025P1380	25	1380	1498	1211	1059	90	90	9	7	42,2	46,2
KK13025P1680	25	1680	1798	1511	1359	90	40	11	9	49,9	53,9

Reference Side

When observed from the motor flange, the reference side is located on the left side of the linear module.

3.1.28 KK130 adapter flanges

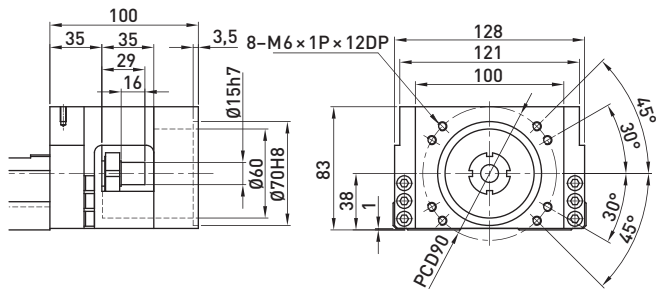

Adapter flange F0

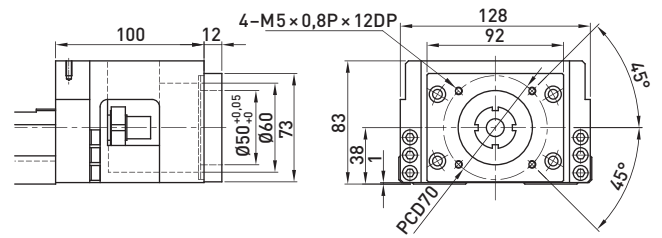

Adapter flange F1

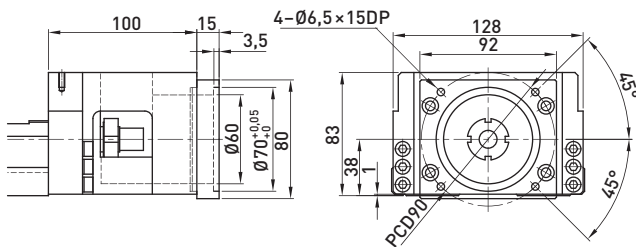

Adapter flange F2

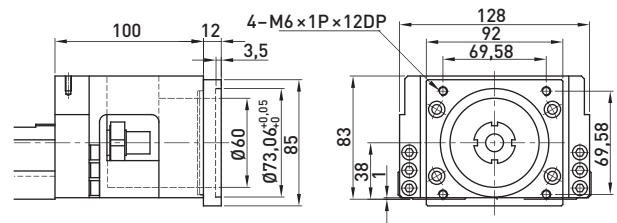

Adapter flange F3

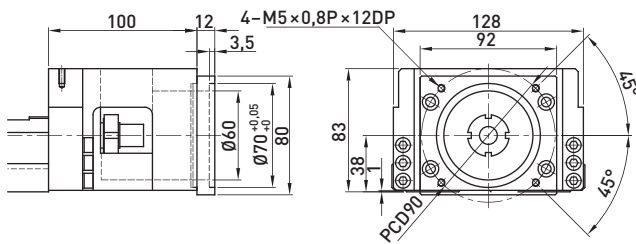

Adapter flange F4

Positioning Systems

KK Linear axes

3.1.29 Accessories for linear axes KK

3.1.29.1 HIWIN servo motor

The HIWIN synchronous AC servo motors are available with outputs of 50 W, 100 W, 200 W, 400 W and 750 W. The standard motors are equipped with a 13-bit encoder with 10 000 increments per revolution, and are available with or without a motor brake as an option.



Table 3.72 Assignment of motor type to KK linear axis

Motor type	Motor performance [W]	Motor torque		KK40	KK50	KK60	KK86	KK100	KK130
		Nominal torque	Peak torque						
FRLS05	50	0,16	0,48	●	●	●			
FRLS10	100	0,32	0,96	●	●	●			
FRLS20	200	0,64	1,92				●	●	●
FRLS40	400	1,27	3,81				●	●	●
FRMS75	750	2,40	7,20					●	●

The motor and encoder cable connections are provided with a connector for the quick and easy connection of extension cables.

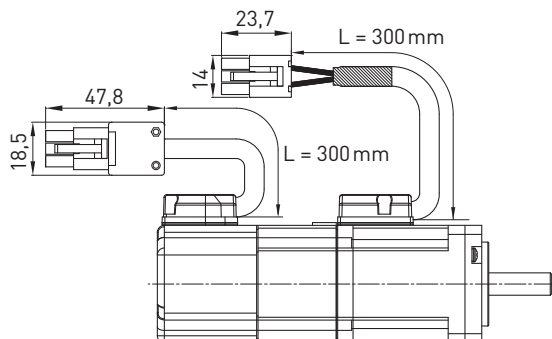

Table 3.73 Motor and encoder cable extension

Length	Motor cable length		Encoder cable
	Without brake	With brake	
3 m	8-10-0627	8-10-0623	8-10-0751
5 m	8-10-0628	8-10-0624	8-10-0752
7 m	8-10-0629	8-10-0625	8-10-0753
10 m	8-10-0630	8-10-0626	8-10-0754

For more information about the HIWIN servo motors, please consult the "Electrical drive technology" catalogue or visit www.hiwin.de

3.1.29.2 HIWIN D2 servo drive

The compact HIWIN D2 servo drive is specially optimised for HIWIN servo motors and is available in the performance classes 100 W, 400 W and 1000 W. The D2 drive offers the following properties:

- Fully digital, vector-controlled drive
- Autotuning function
- Vibration suppression
- Error compensation
- Integrated SPS function
- All connections feature connectors for quick exchange
- 2-line alphanumeric display with 4 control keys on the drive
- Digital pulse-direction interface and analogue +/-10 V interface
- Position control, speed control and torque control
- Inputs/outputs which can be parameterised
- Optional Ethercat interface with CoE (CAN over Ethercat) protocol and DS402 drive profile
- Optional mega-ulink interface
- Efficient and freely available "Lightening" commissioning software



Table 3.74 Assignment of D2 servo drive to motor type

Motor		Servo drive				Linear axis KK
Type	Nominal output	Performance class	D2 _{Standard}	D2 _{EtherCAT}	D2 _{mega-ulink}	
FRLS05	50 W	100 W	8-09-0423	8-09-0441	8-09-0445	KK40, KK50, KK60
FRLS10	100 W	100 W	8-09-0423	8-09-0441	8-09-0445	KK40, KK50, KK60
FRLS20	200 W	400 W	8-09-0422	8-09-0442	8-09-0444	KK86, KK100, KK130
FRLS40	400 W	400 W	8-09-0422	8-09-0442	8-09-0444	KK86, KK100, KK130
FRMS75	750 W	1000 W	8-09-0424	8-09-0443	8-09-0446	KK100, KK130

For more information, please consult the assembly and commissioning instructions available at www.hiwin.de. The "Lightening" commissioning software can also be downloaded for free from our website.

3.1.29.3 Sensor rail with limit switch

The KK linear axis can be ordered with up to three limit switches (inductive PNP proximity switches). The limit switches are mounted on the sensor rail where they can be placed in any position. The limit switches are supplied mounted on the sensor rail attached to the linear axis with open cable ends (cable length 4 m). More details of the limit switches can be found in the "KK linear axes assembly instructions" available at www.hiwin.de.

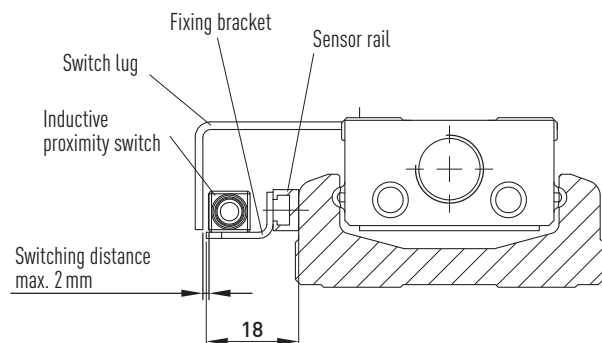

Positioning Systems

KK Linear axes

3.1.29.4 Covers

To protect the linear axes, they can be fitted with aluminium or bellows covers. You will find the dimensions of the KK linear axes with covers in the chapters for the relevant sizes.

Table 3.75 Availability of covers

Model	Aluminium cover	Bellow cover
KK40	●	
KK50	●	
KK60	●	●
KK86	●	●
KK100	●	
KK130	●	

3.1.29.5 Grease nipples

Table 3.76 Grease nipples for grease lubrication

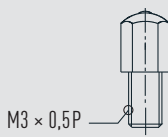
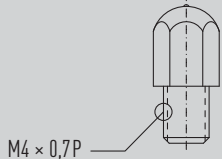
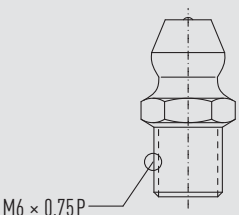
 <p>M3 × 0,5P</p>	 <p>M4 × 0,7P</p>	 <p>M6 × 0,75P</p>
<p>Art.No.: 34310006 KK40</p>	<p>Art.No.: 34310002 KK50, KK60, KK86</p>	<p>Art.No.: 34310008 KK100, KK130</p>

Positioning Systems

KK Linear axes



Linear Guideways



Ballscrews



Linear Motor Systems



Linear Axes with Ballscrews



Linear Actuators



Ball Bearings



Linear Motor Components



Rotary Tables



Drives

Germany

HIWIN GmbH
Brücklesbünd 2
D-77654 Offenburg
Phone +49 (0) 7 81 9 32 78 - 0
Fax +49 (0) 7 81 9 32 78 - 90
info@hiwin.de
www.hiwin.de

Taiwan

Headquarters
HIWIN Technologies Corp.
No. 7, Jingke Road
Nantun District
Taichung Precision Machinery Park
Taichung 40852, Taiwan
Phone +886-4-2359-4510
Fax +886-4-2359-4420
business@hiwin.com.tw
www.hiwin.com.tw

Taiwan

Headquarters
HIWIN Mikrosystem Corp.
No. 6, Jingke Central Road
Nantun District
Taichung Precision Machinery Park
Taichung 40852, Taiwan
Phone +886-4-2355-0110
Fax +886-4-2355-0123
business@hiwinmikro.tw
www.hiwinmikro.tw

Italy

HIWIN Srl
Via De Gasperi, 85
I-20017 Rho (MI)
Phone +39 0 2 93 90 09 41
Fax +39 0 2 93 46 93 24
info@hiwin.it
www.hiwin.it

Poland

HIWIN GmbH
ul. Puławska 405a
PL-02-801 Warszawa
Phone +48 (0) 22 544 07 07
Fax +48 (0) 22 544 07 08
info@hiwin.pl
www.hiwin.pl

Czechia

HIWIN s.r.o.
Medkova 888/11
CZ-62700 BRNO
Phone +42 05 48 528 238
Fax +42 05 48 220 223
info@hiwin.cz
www.hiwin.cz

Slovakia

HIWIN s.r.o., o.z.z.o.
Mládežnícka 2101
SK-01701 Považská Bystrica
Phone +421 424 43 47 77
Fax +421 424 26 23 06
info@hiwin.sk
www.hiwin.sk

Switzerland

HIWIN Schweiz GmbH
Schachenstrasse 80
CH-8645 Jona
Phone +41 (0) 55 225 00 25
Fax +41 (0) 55 225 00 20
info@hiwin.ch
www.hiwin.ch

France

HIWIN France s.a.r.l.
20 Rue du Vieux Bourg
F-61370 Echauffour
Phone +33 (2) 33 34 11 15
Fax +33 (2) 33 34 73 79
info@hiwin.fr
www.hiwin.fr

Austria

HIWIN GmbH
info@hiwin.at
www.hiwin.at

Hungary

HIWIN GmbH
info@hiwin.hu
www.hiwin.hu

Netherlands
HIWIN GmbH
info@hiwin.nl
www.hiwin.nl

Japan

HIWIN Corp.
mail@hiwin.co.jp
www.hiwin.co.jp

USA

HIWIN Corp.
info@hiwin.com
www.hiwin.com

China

HIWIN Corp.
www.hiwin.cn

Korea

HIWIN Corp.
www.hiwin.kr

Singapore

HIWIN Corp.
www.hiwin.sg